

7521/7522/7522A/7523/7524/7527

Software User's Manual

Warranty

All products manufactured by ICP DAS are warranted against defective materials for a period of one year from the date of delivery to the original purchaser.

Warning

ICP DAS assume no liability for damages resulting from the use of this product. ICP DAS reserves the right to change this manual at any time without notice. The information furnished by ICP DAS is believed to be accurate and reliable. However, no responsibility is assumed by ICP DAS for its use, nor for any infringements of patents or other rights of third parties resulting from its use.

Copyright

Copyright 2000 by ICP DAS. All rights are reserved.

Trademark

The names used for identification only may be registered trademarks of their respective companies.

Tables of Contents

1. INTRODUCTION	3
1.1 SOFTWARE INSTALLATION & DEMO PROGRAMS.....	7
1.2 QUICK START1:CONNECTING TO THE 7521.....	9
1.3 QUICK START2: CONNECTING TO SINGLE, REMOTE-RS232-DEVICE.....	15
1.4 QUICK START3: CONNECTING TO MULTI-REMOTE-RS232-DEVICES.....	20
1.5 DOWNLOADING NEW FIRMWARE TO 7521.....	23
1.6 TYPICAL APPLICATIONS.....	26
2. CONNECTING TO THE HP34401A	34
2.1 THE 7521 & THE HP34401A.....	34
2.2 THE PC & THE HP34401A.....	35
2.3 A SINGLE-7522 & SINGLE-HP34401A.....	37
2.4 MULTI-7522 & MULTI-HP34401A.....	44
2.5 A SINGLE-7523 & TWO-HP34401A.....	46
2.6 MULTI-7523S & MULTI-HP34401AS.....	48
3. COMMAND SETS	50
3.1 \$AAA[ADDR].....	52
3.2 \$AABN[BAUD RATE].....	53
3.3 \$AADN[DATA-BIT].....	54
3.4 \$AAPN[DATA-BIT].....	55
3.5 \$AAON[STOP-BIT].....	56
3.6 \$AA6(ID).....	57
3.7 \$AA7.....	58
3.8 \$AAC[DELIMITER].....	59
3.9 \$AAD.....	60
3.10 (DELIMITER)AA(BYPASS).....	61
3.11 \$AAK[CHECKSUM].....	62
3.12 \$AATN[CRLFMODE].....	63
3.13 \$AAW.....	64
3.14 \$AAXV.....	65
3.15 \$AAYN.....	66
3.16 \$AAZNV.....	67
3.17 #**.....	68
3.18 \$AA4.....	69
3.19 \$AA5.....	70
3.20 \$AAF.....	71
3.21 \$AAM.....	71
3.22 \$AA2.....	72
3.23 ~**.....	73
3.24 ~AA0.....	73
3.25 ~AA1.....	74
3.26 ~AA2.....	75
3.27 ~AA3ETT.....	76
3.28 ~AA4P & ~AA4S.....	77
3.29 ~AA5P & ~AA5S.....	78
3.30 \$AAU.....	79
3.31 \$AAL(DATA).....	80
3.32 \$AAR.....	81
4. OPERATIONAL PRINCIPLES & APPLICATION NOTES	82
4.1 DII/INIT* PIN OPERATION PRINCIPLES.....	82
4.2 D/O OPERATING PRINCIPLES.....	83
4.3 D/I OPERATING PRINCIPLES.....	83
4.4 DUAL WATCHDOG OPERATION PRINCIPLE.....	84
4.5 HOST WATCHDOG APPLICATIONS NOTES.....	84
4.6 MODULE WATCHDOG APPLICATIONS NOTES.....	85
4.7 SOURCE CODE OF THE 7521/7522/7523.....	85

1. Introduction

Introduction

There are many RS-232 devices used in industry applications. Nowadays, linking all these RS-232 devices together for both automation & information important. Usually, these devices are far away from the host-PC. In modern situation, multi-serial card linking is inefficient. Our 752x series products can link multiple RS-232 devices via a single RS-485 network. This network protocol offers stability, reliability and simple cabling while delivering a low –cost, easy-to-maintain product..

Addressable RS-232 Converter

Most RS-232 devices don't support device addresses. Our I-752X series can assign a unique address to any RS-232 device installed in a RS-485 network. Once the host-PC sends a command with a device address to the RS-485 network, the destination-752x will remove the address field & pass the other commands to its local RS-232 device. The response of this local RS-232 device will be returned to the host-PC via the I-752x.

Master-type Addressable RS-232 Converter

ICPDAS' 752x products are unique. Our 752X products are Master-type converters, while other converters are Slave-type. Slave-type converters are helpless without a host-PC. In real industrial applications, customers are not satisfied with Slave-type converters because they can not adapt to individual demands. The powerful 752x series analyzes local RS-232 devices, D/I or D/O without a host-PC. Refer to Application 5~9 for more information.

Onboard 1K byte Queue-buffer

The I-752X equips a 1K byte queue-buffer for its local RS-232 device. All input data can be stored in the queue-buffer until the host-PC has time to read it. These features allow the host-PC to link thousands of RS-232 devices without losing any data.

Onboard D/I signal trigger

The I-752X is equipped with 3-channels of digital input for sensor interfacing. These D/I are linked to a photo sensor/switch to act as a signal. They also can be used as general purpose D/I. The 752X can read & analyze these D/I without the help of host-PC.

Onboard D/O for emergency control

The I-752X equips 3-channels of digital output for emergency control. The D/O can directly drive relay or led. They can be used to control the local devices for emergency event. The 752x can control these D/O without the help of host-PC.

3000V isolation on RS-485 site

The COM2 of the I-752x is an isolated RS-485 port with 3000V isolation. This isolation will protect the local RS-232 devices from transient noises coming from RS-485 network.

Self-Tuner ASIC inside

The I-752X Self-Tuner ASIC for RS-485 port. This chip can auto detect and control the send/receive direction of the RS-485 network. Therefore the application programs don't have to take care of the direction control of the RS-485 network.

Embedded control capabilities

Besides Intelligent Communication Controller, the I-752X series products can be used as an embedded controller. Every I-752X controller has a, MiniOS7, embedded O.S.. The MiniOS7 provides equivalent functions of ROM DOS and has more features. The user can use well-developed libraries and demo programs to implement his controller.

Wide range selection

The I-752X series products have I-7521, I-7521D, I-7522, I-7522D, I-7522A, I-7522A, I-7523, I-7523D, I-7524, I-7524D, I-7527 and I-7527D. The I-7521 provides one RS-232 port, one RS-485 port, 3 digital input channels and 3 digital output channels. The I-7522 provides two RS-232 ports, one RS-485 port, two digital input channels and one digital output channel. The I-7522A provides one RS-232/RS-

485 port, one RS-485 port, one RS-422/RS-485 port, 5 digital input channels and 5 digital output channels. The I-7523 provides three RS-232 ports, one RS-485 port. The I-7524 provides 4 RS-232 ports, two RS-485 ports, 1 digital input channels and 1 digital output channels. The I-7527 provides seven RS-232 ports, two RS-485 ports, 1 digital input channels and 1 digital output channels. The COM 1 of the I-7521, I-7522, I-7522A, I-7523, I-7524 and I-7527 can be used as RS-232 port or RS-485 port.

The 7188XC/XB & 752X series

The 7521/22/22A/23/24/27 is really an embedded controller before any firmware is downloaded. After downloading the firmware, the 7521/22/22A/23/24/27 acts as an “Intelligent Communication Controller”. The only difference between the 7521/22/23 & the 7188XC is the 3000V isolation on the RS-485 port. **In general, the 7521/22/23 is equivalent to 7188XC+7510.** Therefore the 7521/7522/7523 can be used as an embedded controller with an isolated RS-485 port. The only difference between the 7522A/24/27 & the 7188XB is the 3000V isolation on the RS-485 port. **In general, the 7522A/24/27 is equivalent to 7188XB+7510.** Therefore the 7522A/7524/7527 can be used as an embedded controller with an isolated RS-485 port.

Cost Effective Solution

The 7188/7188XA/7188XB/7188XC is designed as an embedded controller. Therefore, an any software can be downloaded to them. If the firmware for “Intelligent Communication Controller” is downloaded to the into 7188/7188XA/7188XB/7188XC, they will act as an “Intelligent Communication Controller”.

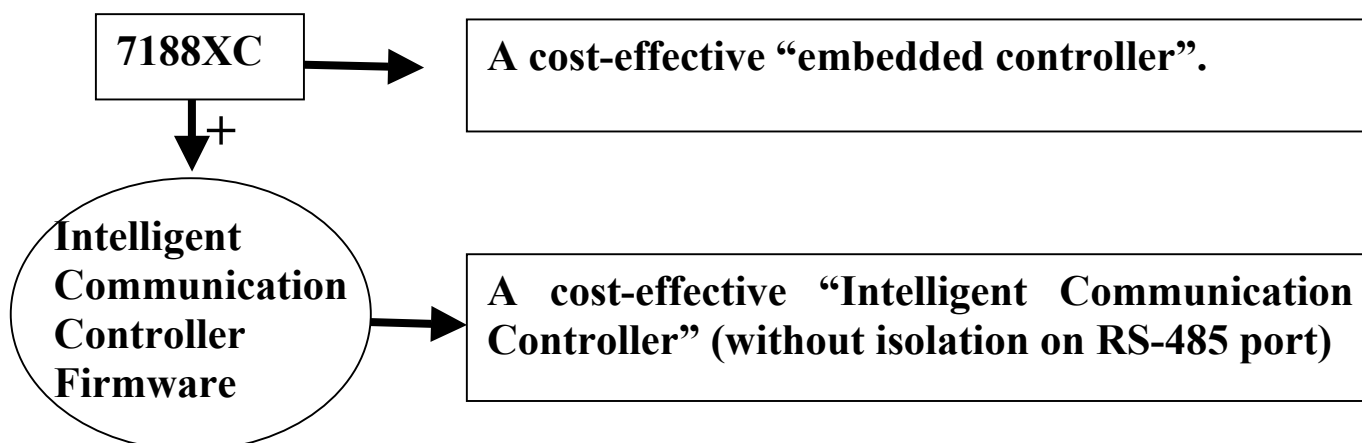

Features

- Built-in “Addressable RS-232 Converter” firmware
- Supports about 30 well-defined commands
- Supports Dual-Watchdog commands
- Supports Power-up value & safe value for D/O
- The source code of firmware is open & well-documented
- User can modify the source code according to their specific requirements.
- The firmware can monitor the onboard D/I and control the onboard D/O in real-time according to user’s requirements
- The firmware can monitor the RS-232 device and control the onboard D/O in real-time according to user’s requirements
- The 7521 supports one RS-232 device
- The 7522 supports two RS-232 devices
- The 7522A supports one RS-232 device
- The 7523 supports three RS-232 devices
- The 7524 supports four RS-232 devices
- The 7527 supports seven RS-232 devices
- Watchdog timer provides fault tolerance and recovery
- Low power consumption

Ordering Information

- 7521** : Single-channel “Intelligent Communication Controller”
7521D : 7521 with 5-digit 7-seg LED.
7522 : Dual-channel “Intelligent Communication Controller”
7522D : 7522 with 5-digit 7-seg LED.
7522A : Single-channel “Intelligent Communication Controller”
7522AD : 7522A with 5-digit 7-seg LED.
7523 : Three-channel “Intelligent Communication Controller”
7523D : 7523 with 5-digit 7-seg LED.
7524 : Four-channel “Intelligent Communication Controller”
7524D : 7522 with 5-digit 7-seg LED.
7527 : Seven-channel “Intelligent Communication Controller”
7527D : 7522 with 5-digit 7-seg LED.

1.1 Software installation & demo programs

Software Installation:

- make a working directory in your computer, then
- insert the installation CD and wait for autorun(or Run auto32.exe)
- click “Toolkits(Softwares)/ Manuals”
- click “718XA/B/C & 7521/2/2A/3/4/7 Series”
- click “Demo Program”, the following like window is shown:

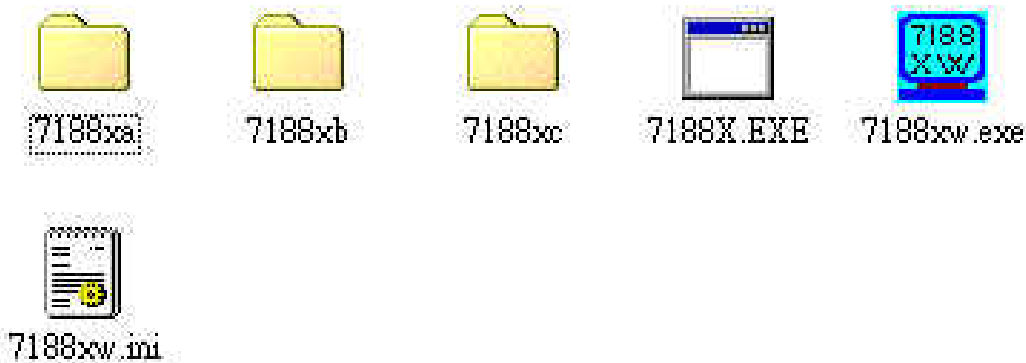

- Select all the files and directories and copy them to the working location/directory
- Copy the 7188X.EXE/7188XW.EXE to the PATH directory, for example, C:\DOS or C:\WINDOWS, then you can execute 7188X.EXE/7188XW.EXE from any location.

Files description:

File name	Location	Description	Hardware
Xbyymmdd.img	7188XB\DEMO\	The image file for MiniOS7 yy:00→2000 mm: month dd: day	7522A/7524/ 7527
7522A.C	7188XB\DEMO\TC30\7522A	The source code of 7522A	7522A
7522A.EXE	7188XB\DEMO\TC30\7522A	The firmware of 7522A	7522A
7524.C	7188XB\DEMO\TC30\7524	The source code of 7524	7524
7524.EXE	7188XB\DEMO\TC30\7524	The firmware of 7524	7524
7527.C	7188XB\DEMO\TC30\7527	The source code of 7527	7527
7527.EXE	7188XB\DEMO\TC30\7527	The firmware of 7527	7527
Xcyymmdd.img	7188XC\DEMO\	The image file for MiniOS7 yy:00→2000 mm: month dd: day	7521/7522/ 7523
7521.C	7188XC\DEMO\BC\7521	The source code of 7521	7521
7521.EXE	7188XC\DEMO\BC\7521	The firmware of 7521	7521
7522.C	7188XC\DEMO\BC\7522	The source code of 7522	7522
7522.EXE	7188XC\DEMO\BC\7522	The firmware of 7522	7522
7523.C	7188XC\DEMO\BC\7523	The source code of 7523	7523
7523.EXE	7188XC\DEMO\BC\7523	The firmware of 7523	7523

start	7188XC\	Containing source code for Quick Start.	7521/7522/7523
com.h	7188XC\start	Header file for all quick start program	7521/7522/7523
hp34401a.c	7188XC\start	PC link to HP34401A	7521/7522/7523
hp22_1.c	7188XC\start	7522 link to HP 34401A	7521/7522/7523
hp22_m.c	7188XC\start	Multi-7522 link to HP 34401A	7521/7522/7523
hp23_1.c	7188XC\start	7523 link to HP 34401A	7521/7522/7523
hp23_m.c	7188XC\start	Multi-7523 link to HP 34401A	7521/7522/7523
7521ODM1	7188XC\DEMO\BC\	7521+ real time control D/IO	7521
7521ODM2	7188XC\DEMO\BC\	7521+ real time control AD&DA	7521
7521ODM3	7188XC\DEMO\BC\	7521+ real time control Event counter	7521
7521ODM4	7188XC\DEMO\BC\	7521+ real time control Sensor & Multiplex	7521
7521ODM5	7188XC\DEMO\BC\	7521+ real time monitor HP34401A & alarm control	7521
lib	7188XB\DEMO\	7188xbs.lib → for SMALL program. (TC/BC++/MSC/MSVC++) 7188xbl.lib → for LARGE program. (TC/BC++/MSC/MSVC++) 7188xb.h → All the functions declared are in the 7188xb.h, please use #include"7188xb.h". 7188xb.h is put on the same directory as 7188xbs.lib	7522A/7524/7527
lib	7188XC\	7188xs.lib → for SMALL program. (TC/BC++/MSC/MSVC++) 7188xl.lib → for LARGE program. (TC/BC++/MSC/MSVC++) 7188x.h → All the functions declared are in the 7188x.h, please use #include"7188x.h". 7188x.h is put on the same directory as 7188xs.lib	7521/7522/7523

1.2 Quick Start1:Connecting to the 7521

Step 1: connect the 7521 to the RS-485 networking as follows:

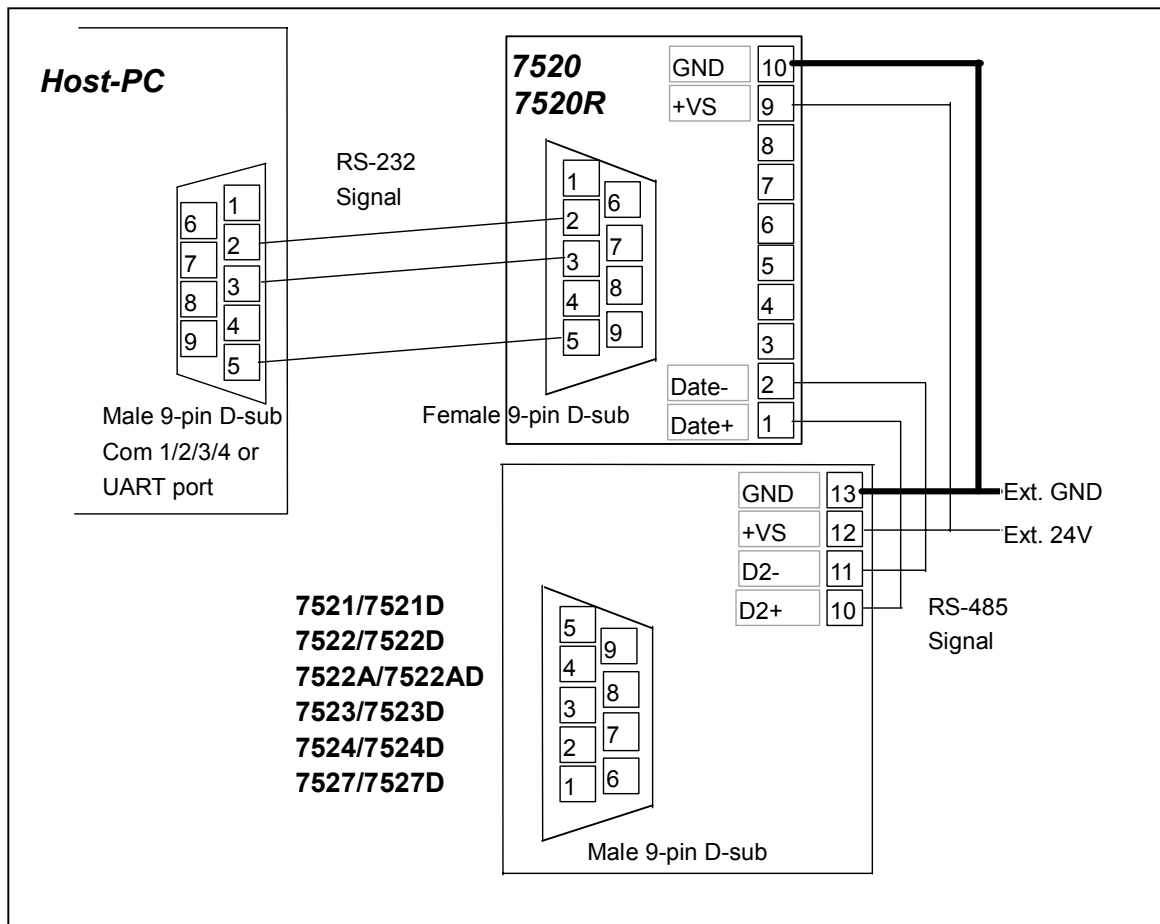
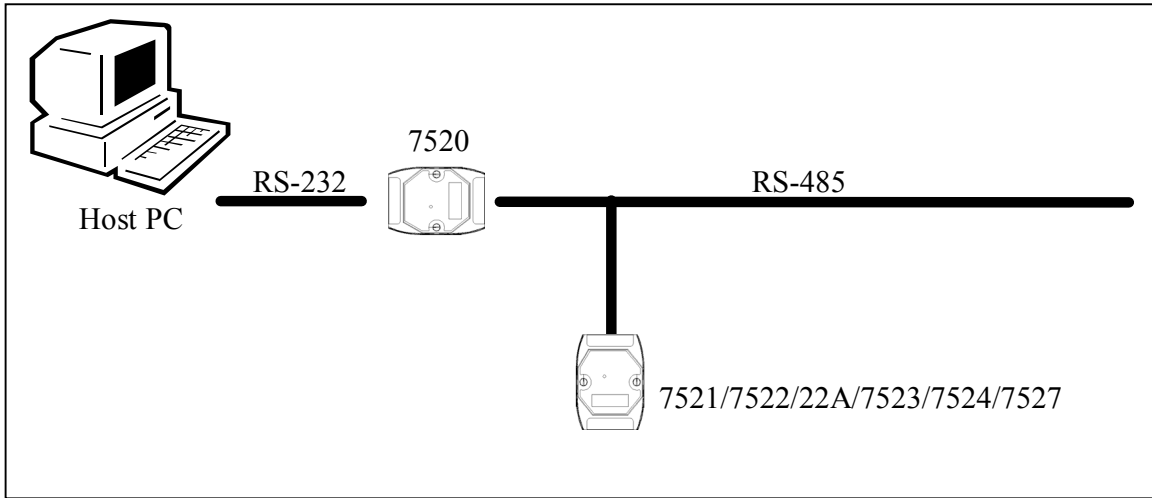

Step 2: Execute 7188X.EXE in the Host-PC

Step 3: Select the active COM port of HOST-PC

If the 7520 is connected to COM1, then Press ALT & 1

If the 7520 is connected to COM2, then Press ALT & 2

Step 4: Change the baud rate to 9600

Press ALT & C first

Then press the SPACE-key several times until baud rate = 9600

Press the ENTER-key to confirm

Step 5: Change the Parity-bit to N

Press the SPACE-key several times until Parity-bit = N

Press the Enter-key to confirm

Step 6: Change the Data-bit to 8

Press the SPACE-key several times until Data-bit = 8

Press the Enter-key to confirm

Step 7: Change the Stop-bit to 1

Press the SPACE-key several times until Stop-bit = 1

Press the Enter-key to confirm

Step 8: Change the 7188x to Line-Command-mode

Press ALT & L

The screen will show as follows:

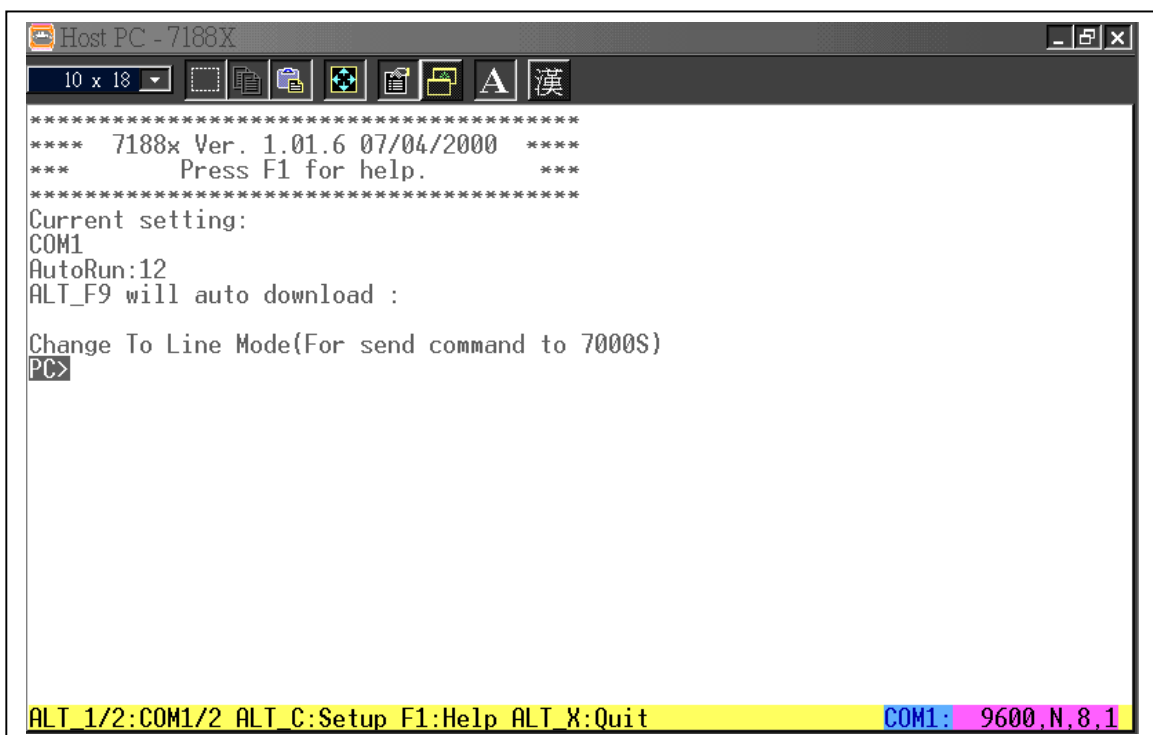

The screenshot shows a window titled "Host PC - 7188X" with a standard Windows XP-style title bar. The main area contains the following text:

```
*****  
**** 7188x Ver. 1.01.6 07/04/2000 ****  
*** Press F1 for help. ***  
*****  
Current setting:  
COM1  
AutoRun:12  
ALT_F9 will auto download :  
Change To Line Mode(For send command to 7000S)  
PC>
```

At the bottom of the window, there is a yellow status bar with the text: "ALT 1/2:COM1/2 ALT C:Setup F1:Help ALT X:Quit" and a blue status bar with the text: "COM1: 9600,N,8,1".

Step 9: Power-on the 7521(make sure DI1/INIT* is floating)
 Check that the five 7-seg LED shows as follows:

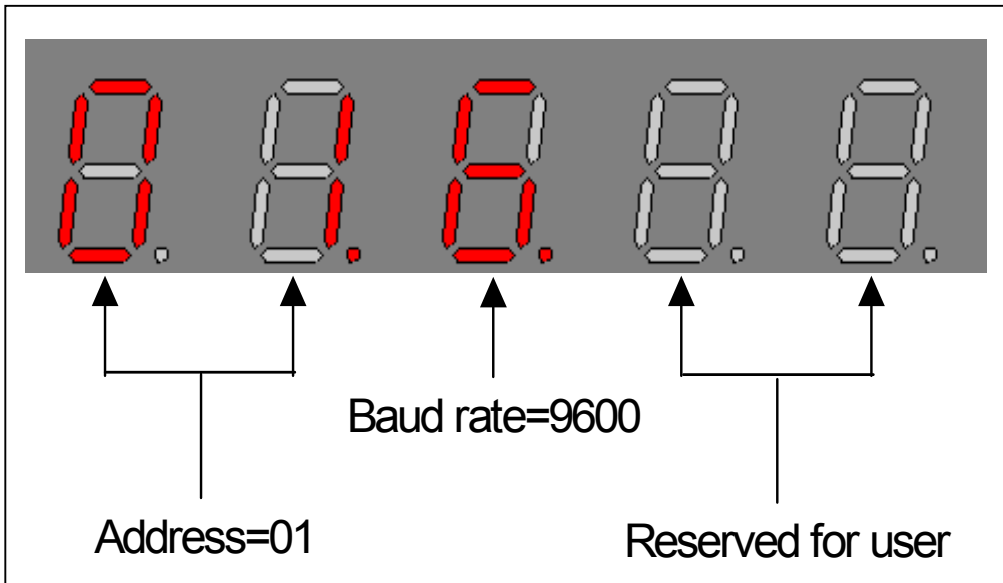

Step 10: Get the Module-Name of the 7521
 Key-in command → \$01M
 Then press the ENTER-key to send command to the 7521
 Check that the 7521 echoes → !017521

Step 11: Get the Version of the 7521
 Key-in command → \$01F
 Then press the ENTER-key to send command to the 7521
 Check that the 7521 echoes → !01A1.0
 Key-in command → \$012
 Then press the ENTER-key to send command to 7521
 Check that the 7521 echoes → !016800

```

Host PC - 7188X
10 x 18
*****
*** 7188x Ver. 1.01.6 07/04/2000 ***
*** Press F1 for help. ***
*****
Current setting:
COM1
AutoRun:12
ALT_F9 will auto download :
Change To Line Mode(For send command to 7000S)
PC>$01M
7000>!017521
PC>$01F
7000>!01A1.0
PC>$012
7000>!016800
PC>

ALT 1/2:COM1/2 ALT C:Setup F1:Help ALT X:Quit COM1: 9600,N,8,1
  
```

Step 12: Change the Module-Address of the 7521

Key-in command → \$01A02

Then press the ENTER-key to send command to the 7521

Check that the five 7-seg LED will shows as follows:

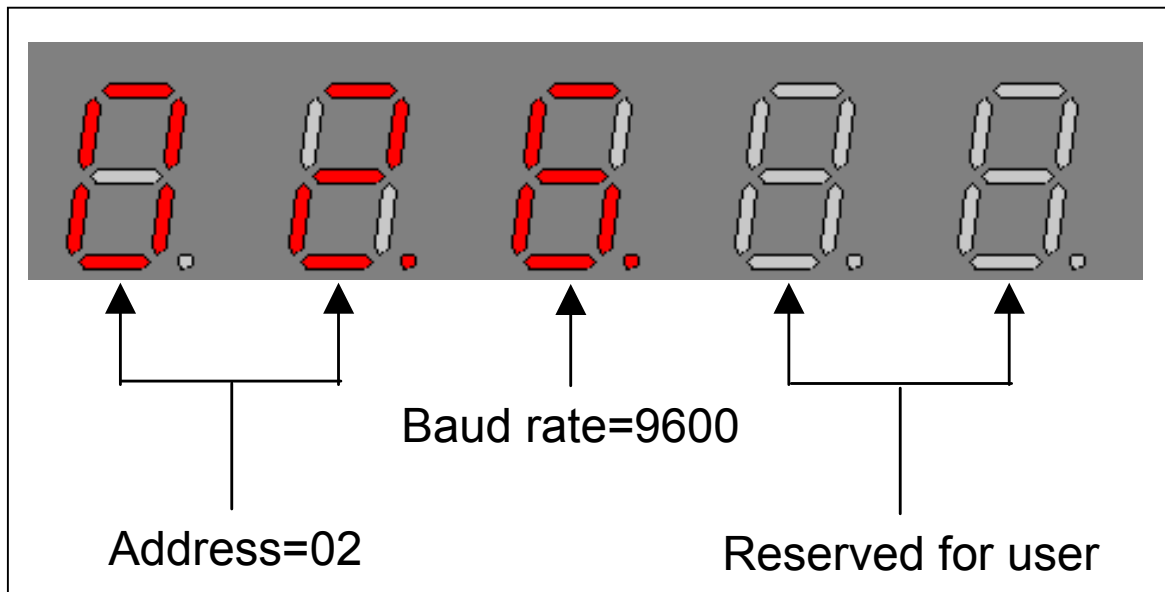

Key-in command → \$02M

Then press the ENTER-key to send command to the 7521

Check that the 7521 echoes → !027521

```
Host PC - 7188X
10 x 18
*****
*** 7188x Ver. 1.01.6 07/04/2000 ***
*** Press F1 for help. ***
*****
Current setting:
COM1
AutoRun:12
ALT_F9 will auto download :

Change To Line Mode(For send command to 7000S)
PC>$01M
7000>!017521
PC>$01F
7000>!01A1.0
PC>$01A02
7000>!01
PC>$02M
7000>!027521
PC>

ALT_1/2:COM1/2 ALT_C:Setup F1:Help ALT_X:Quit COM1: 9600,N,8,1
```

Step 13: Change the baud rate of the 7521

Key-in command → \$02B0115200

Then press the ENTER-key to send command to the 7521

Check that the five 7-seg LED shows as follows:

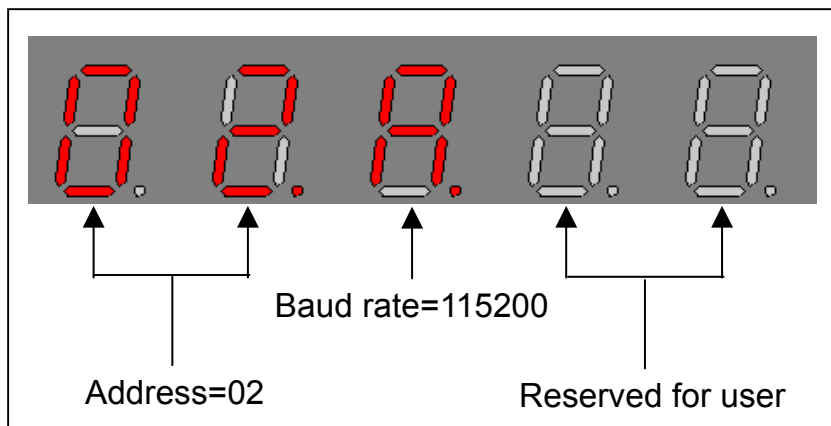

Press ALT & C

Press the SPACE-KEY until 115200 is shown

Then press the ENTER-KEY to confirm baud rate=115200

Press the ENTER-KEY to confirm parity-bit=N

Press the ENTER-KEY to confirm data-bit=8

Press the ENTER-KEY to confirm stop-bit=1

Key-in command → \$02M

Then press the ENTER-key to send command to the 7521

Check that the 7521 echoes → !027521

Key-in command → \$022

Then press the ENTER-key to send command to the 7521

Check that the 7521 echoes → !02A800

```
Host PC - 7186X
10 x 18
*****
Current setting:
COM1
AutoRun:12
ALT_F9 will auto download :

Change To Line Mode(For send command to 7000S)
PC>$01M
7000>!017521
PC>$01F
7000>!01A1.0
PC>$01A02
7000>!01
PC>$02M
7000>!027521
PC>$02B0115200
7000>!02
PC>$02M
7000>!027521
PC>$022
7000>!02A800
PC>

ALT_1/2:COM1/2 ALT_C:Setup F1:Help ALT_X:Quit COM1:115200,N,8,1
```

Step 14: Change the Module-Address of the the 7521
Key-in command → **\$02A01**
Then press the **ENTER-key** to send command to the 7521

Step 15: Change the baud rate of the 7521
Key-in command → **\$01B09600**
Then press the **ENTER-key** to send command to the 7521
Press **ALT & C**
Press the SPACE-KEY until 9600 is shown
Then press the **ENTER-KEY** to confirm baud rate=**9600**
Press the **ENTER-KEY** to confirm parity-bit=**N**
Press the **ENTER-KEY** to confirm data-bit=**8**
Press the **ENTER-KEY** to confirm stop-bit=**1**
Key-in command → **\$01M**
Then press the **ENTER-key** to send command to the 7521
Check the 7521 echoes → **!017521**

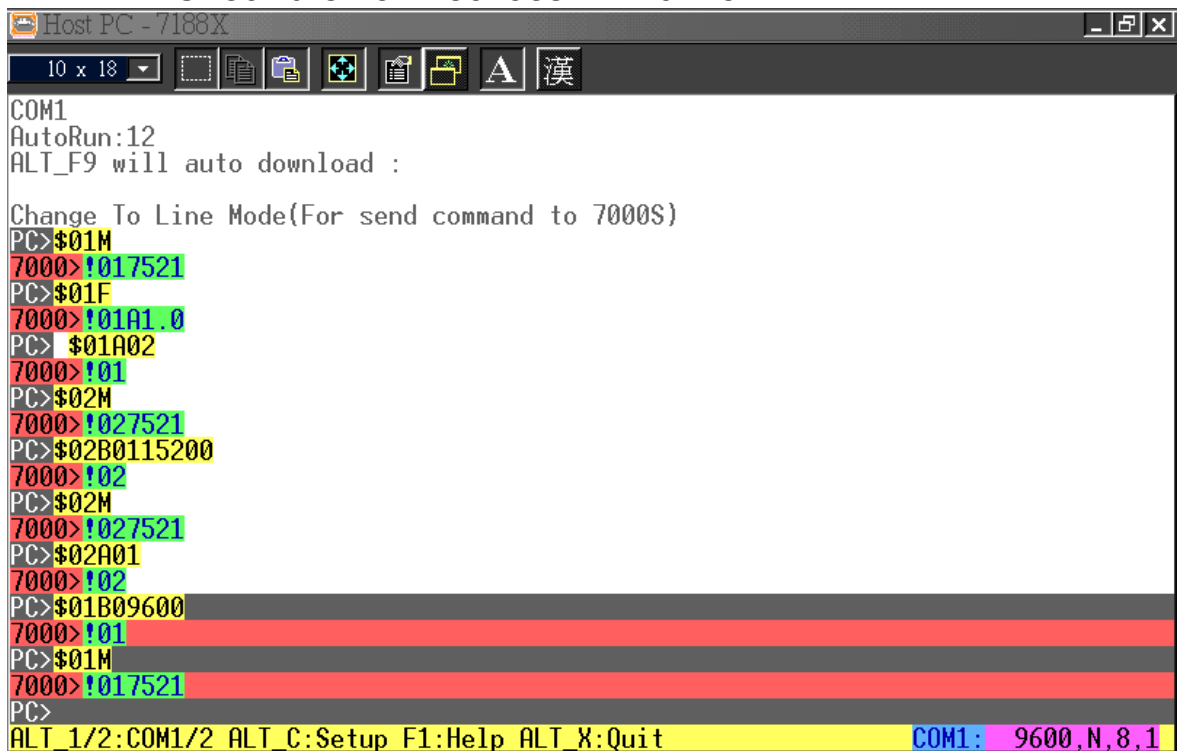

```
Host PC - 7188X
10 x 18
COM1
AutoRun:12
ALT_F9 will auto download :

Change To Line Mode(For send command to 7000S)
PC>$01M
7000>!017521
PC>$01F
7000>!01A1.0
PC>$01A02
7000>!01
PC>$02M
7000>!027521
PC>$02B0115200
7000>!02
PC>$02M
7000>!027521
PC>$02A01
7000>!02
PC>$01B09600
7000>!01
PC>$01M
7000>!017521
PC>
ALT_1/2:COM1/2 ALT_C:Setup F1:Help ALT_X:Quit COM1: 9600,N,8,1
```

1.3 Quick Start2: Connecting to Single, Remote-RS232-Device

Step 1: connect the 7521 to the RS-485 networking & remote-PC as follows:

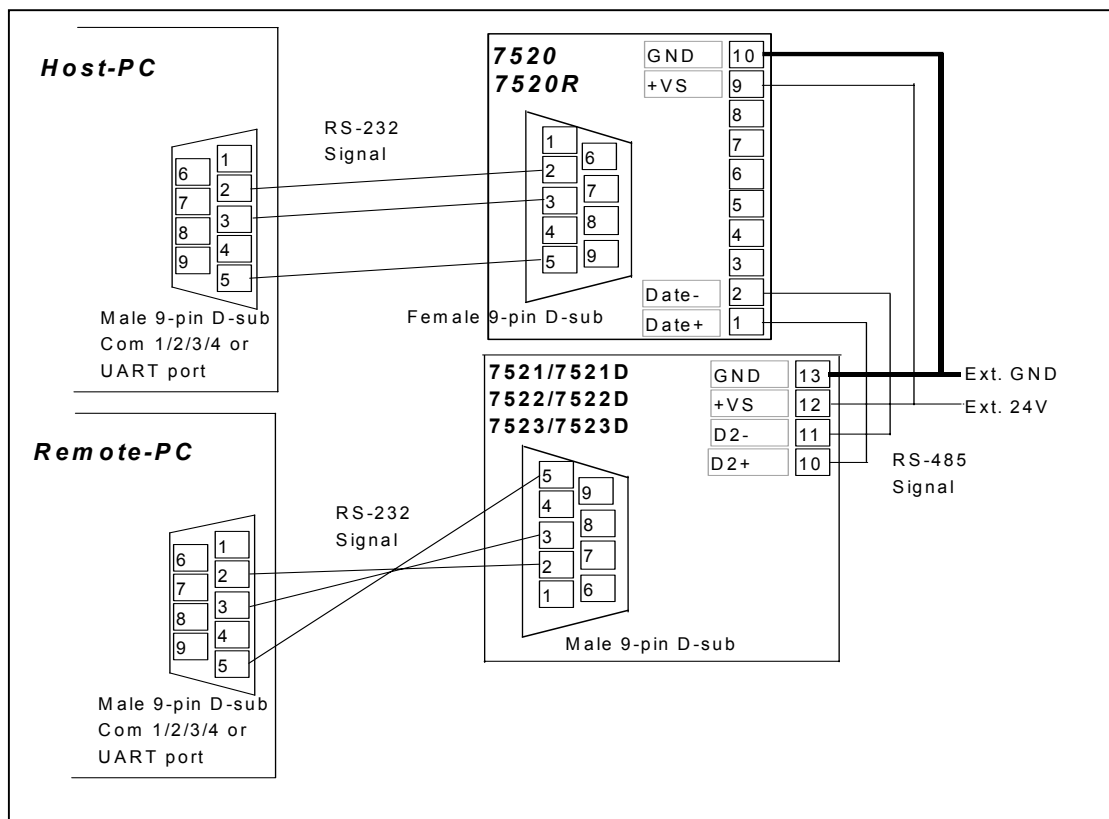
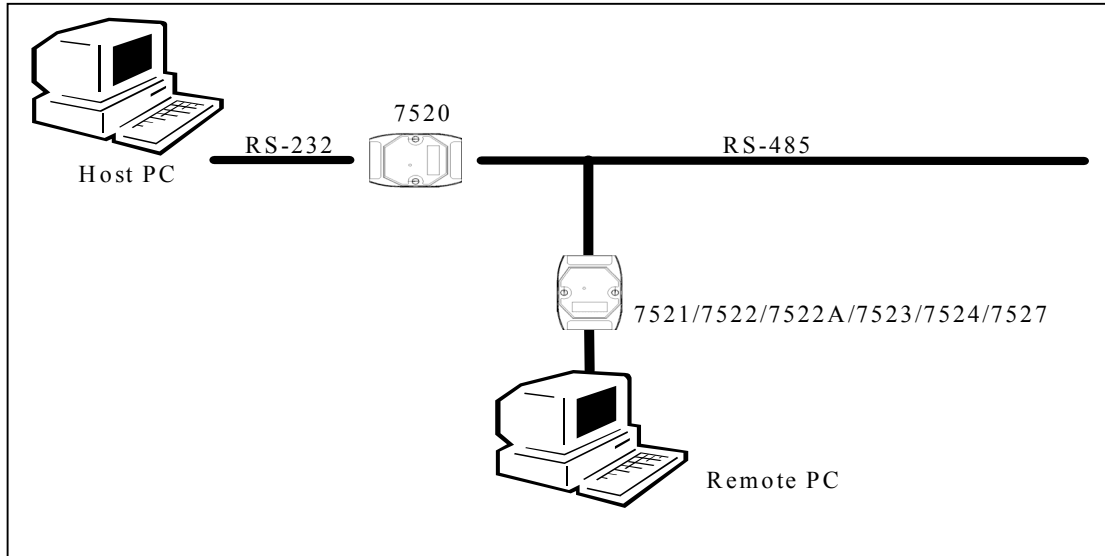

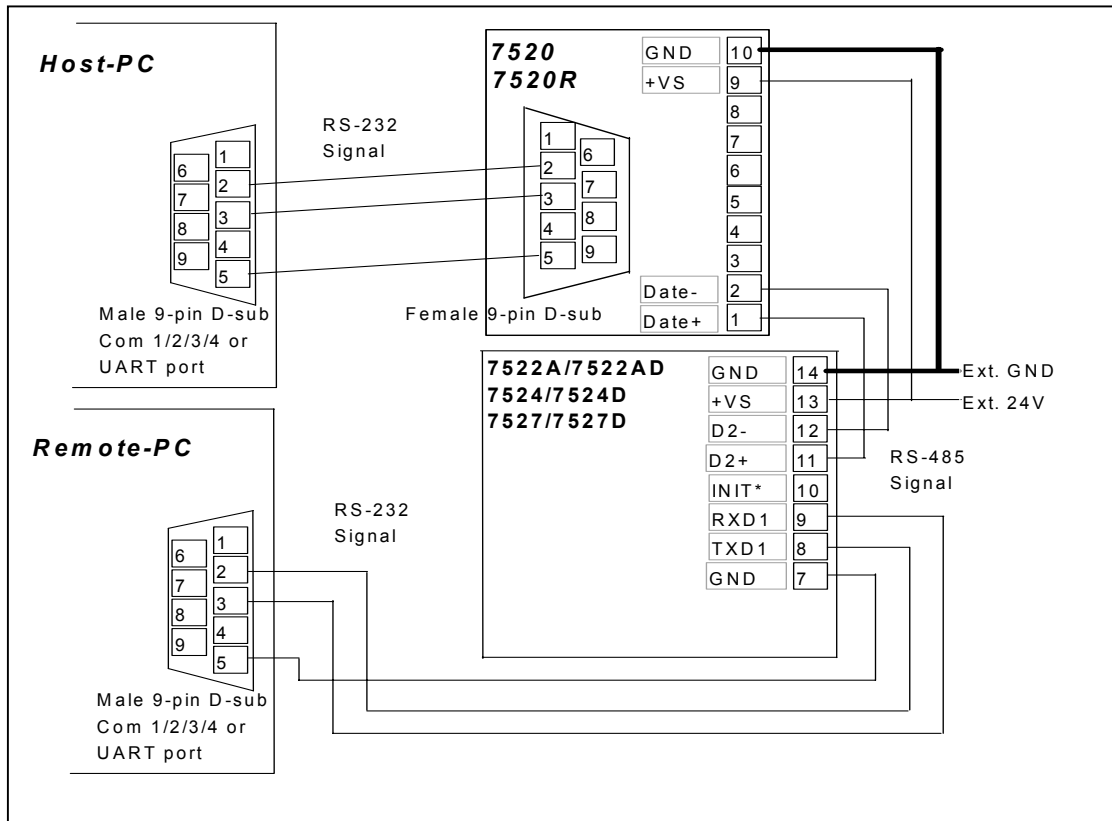

- Step 2: Execute 7188X.EXE in the Host-PC
Refer to Step3 through o Step 8 of Quick Start 1 to change
COM port & status to **9600, N, 8, 1**
- Step 3: Execute 7188X.EXE in the Remote-PC
Refer to Step3 through Step 8 of Quick Start 1 to change
COM port & status to **9600, N, 8, 1**
- Step 4: Host-PC Sends **abcde** to Remote-PC
Keyin **:01abcde**
Press the Enter-key to send command string to the 7521
Check that the response-string from Remote-PC is **abcde**
The screen should be shown on Host-PC as follows:

```
Host PC - 7188x
10 x 18
*****
*** 7188x Ver. 1.01.8 08/10/2000 ***
*** Press F1 for help. ***
*****
Current setting:
COM1
AutoRun:
ALT_F9 will auto download :

Change To Line Mode(For send command to 7000S)
PC>$01M
7000>!017522
PC>:01abcde
7000>TimeOut
PC>

ALT 1/2:COM1/2 ALT_C:Setup F1:Help ALT_X:Quit COM1: 9600,N,8,1
```

The screen on the Remote-PC should show as follows:

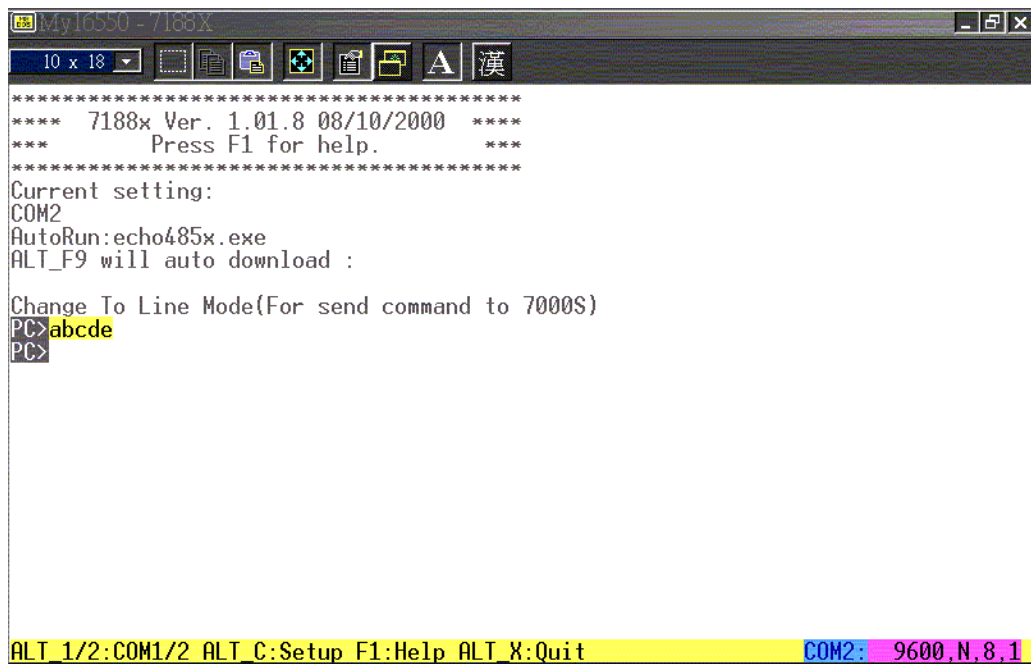

```
My16550 - 7188X
10 x 18
*****
**** 7188x Ver. 1.01.8 08/10/2000 ****
***   Press F1 for help.   ***
*****
Current setting:
COM2
AutoRun:echo485x.exe
ALT_F9 will auto download :

Change To Line Mode(For send command to 7000S)
PC> abcde
PC>
```

ALT 1/2:COM1/2 ALT C:Setup F1:Help ALT X:Quit COM2: 9600,N,8,1

Step 5: Host-PC Sends **12345** to Remote-PC
Keyin **:0112345**
Press the Enter-key to send command string to the 7521
Check that the response-string from Remote-PC is **12345**
The screen should be shown on Host-PC as follows:

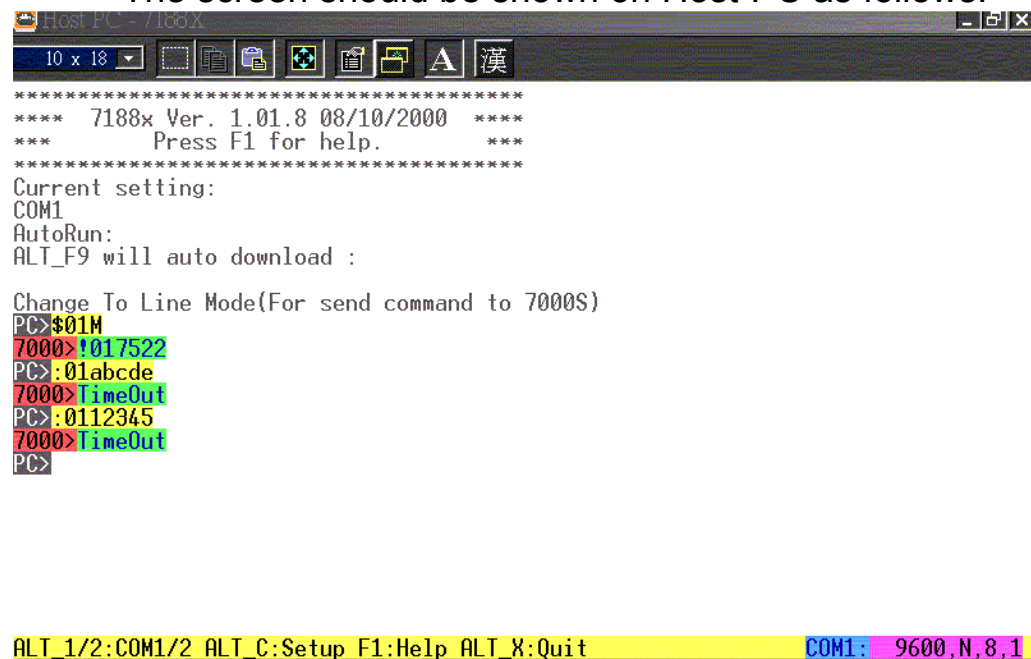

```
Host-PC - 7188X
10 x 18
*****
**** 7188x Ver. 1.01.8 08/10/2000 ****
***   Press F1 for help.   ***
*****
Current setting:
COM1
AutoRun:
ALT_F9 will auto download :

Change To Line Mode(For send command to 7000S)
PC> #01M
7000> !017522
PC> :01abcde
7000> TimeOut
PC> :0112345
7000> TimeOut
PC>
```

ALT 1/2:COM1/2 ALT C:Setup F1:Help ALT X:Quit COM1: 9600,N,8,1

The screen on the Remote-PC should show as follows:

```
***** 7188x Ver. 1.01.8 08/10/2000 *****
*** Press F1 for help. ***
Current setting:
COM2
AutoRun:echo485x.exe
ALT_F9 will auto download :
Change To Line Mode(For send command to 7000S)
PC>abcde
PC>12345
PC>
```

ALT 1/2:COM1/2 ALT_C:Setup F1:Help ALT_X:Quit COM2: 9600,N,8,1

Note: If no Remote-PC is available. One can connect TxD and Rxd to the same COM port to test:

```
***** 7188x Ver. 1.01.6 07/04/2000 *****
*** Press F1 for help. ***
Current setting:
COM1
AutoRun:7521test.exe
ALT_F9 will auto download :
Change To Line Mode(For send command to 7000S)
PC>TimeOut
PC>$01M
7000>!017522
PC>:01NoRemotePC
7000>NoRemotePC
PC>
```

ALT 1/2:COM1/2 ALT_C:Setup F1:Help ALT_X:Quit COM1:115200,N,8,1

1.4 Quick Start3: Connecting to Multi-Remote-RS232-Devices

Step 1: Refer to Quick Start1 for wiring & change the 7521 to **Address-02, & 9600, N, 8, 1**

Step 2: connect the second 7521 to the RS-485 networking & two remote-PCs as follows:

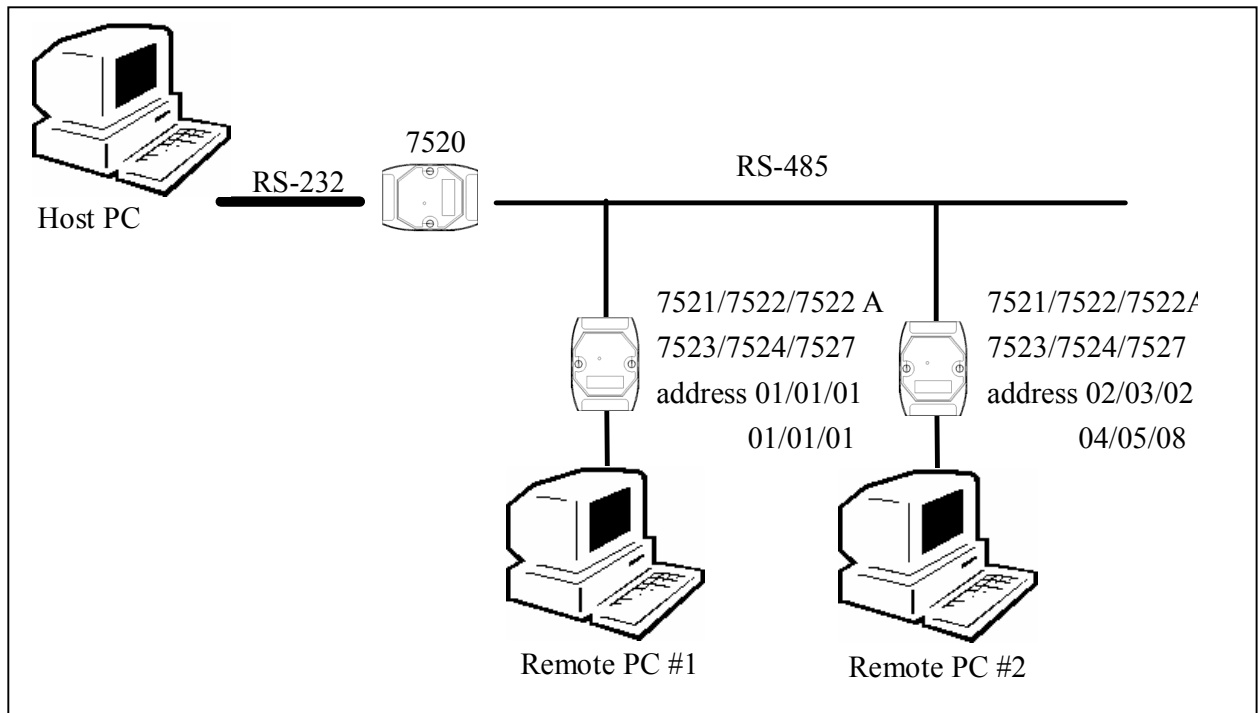

Now there are two 7521s in the RS-485 network. The module address of one 7521 is **address-01**, the other is **address-02**. The communication status of these two 7521 will be same as **N, 8, 1**

Step 3: Execute 7188X.EXE in the two, Remote-PCs
Refer to Step3 through Step 8 of Quick Start 1 to change COM port & status to **9600, N, 8, 1**

Step 4: Host-PC Sends **To-Remote-PC1** to Remote-PC1
 Keyin **:01To-Remote-PC1**
 Press the Enter-key to send command string to the 7521
 The screen on the Host-PC will show as follows:

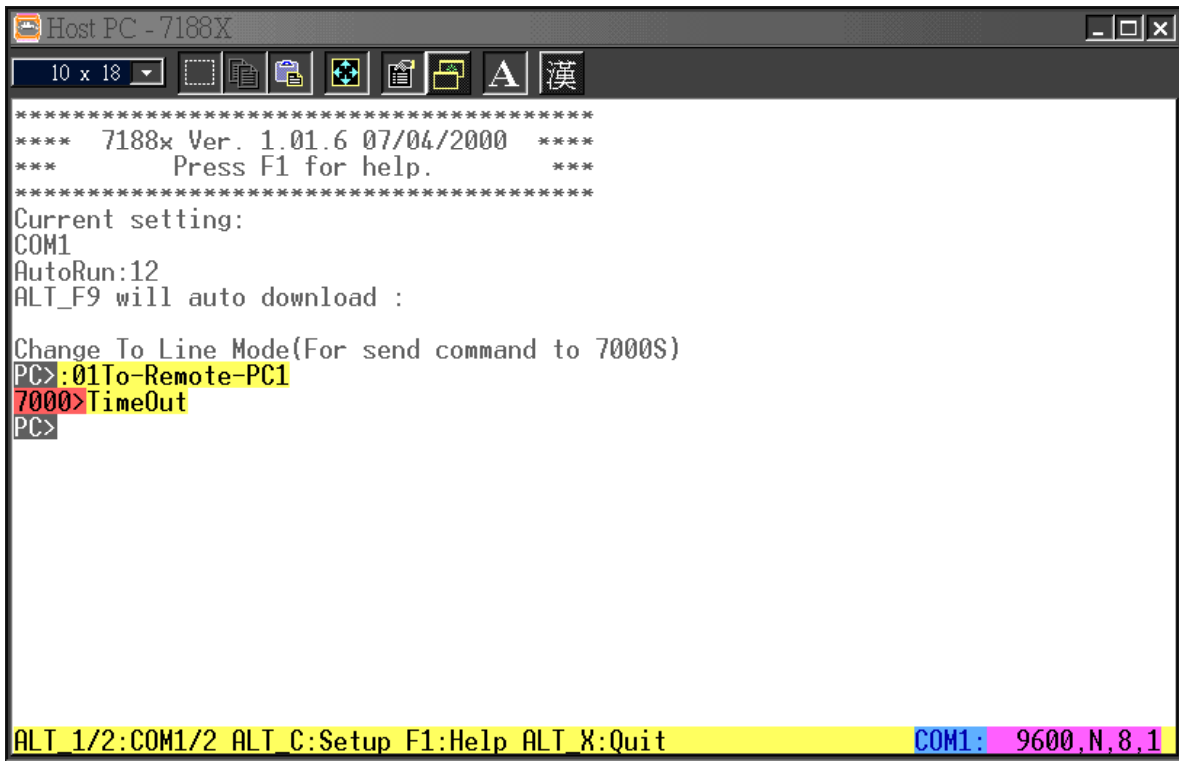

The screen on the Host-PC will show as follows:

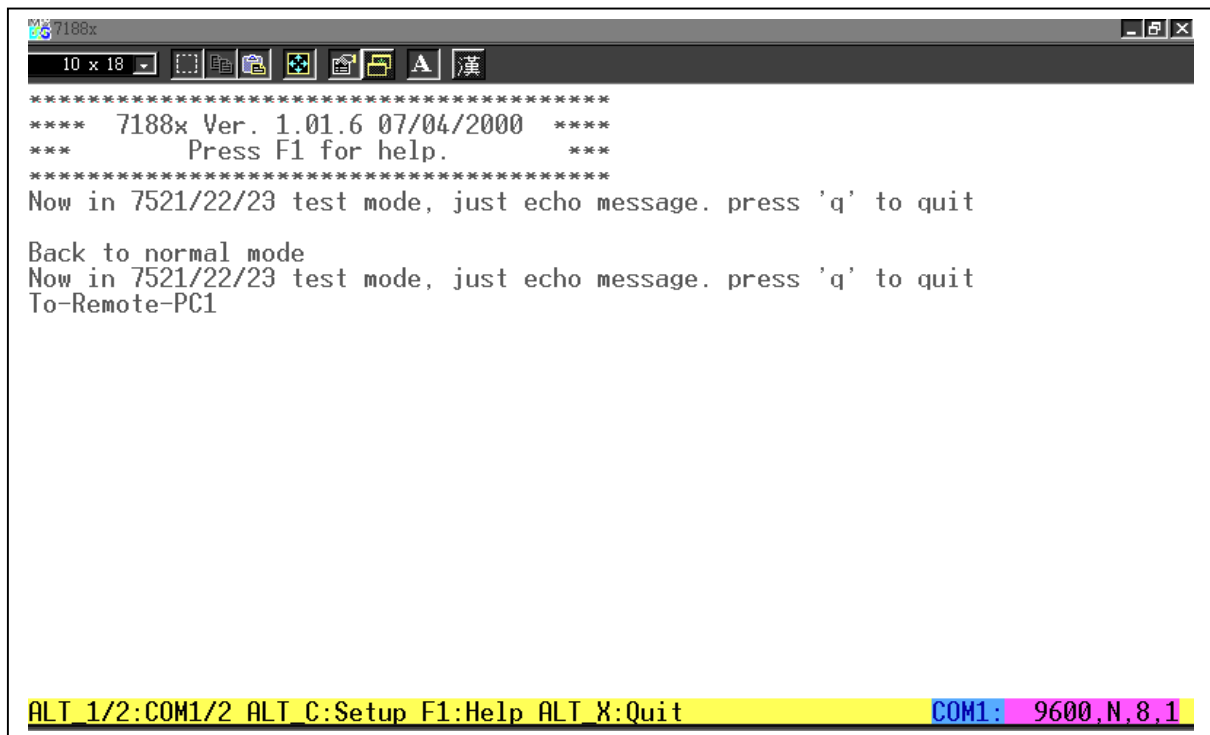

Step 5: Host-PC Sends **To-Remote-PC2** to Remote-PC2

Keyin :**02To-Remote-PC2**

Press the Enter-key to send command string to the 7521

Keyin :**02To-Remote-PC2**

Press the Enter-key to send command string to the 7521

The screen on the Host-PC will show as follows:

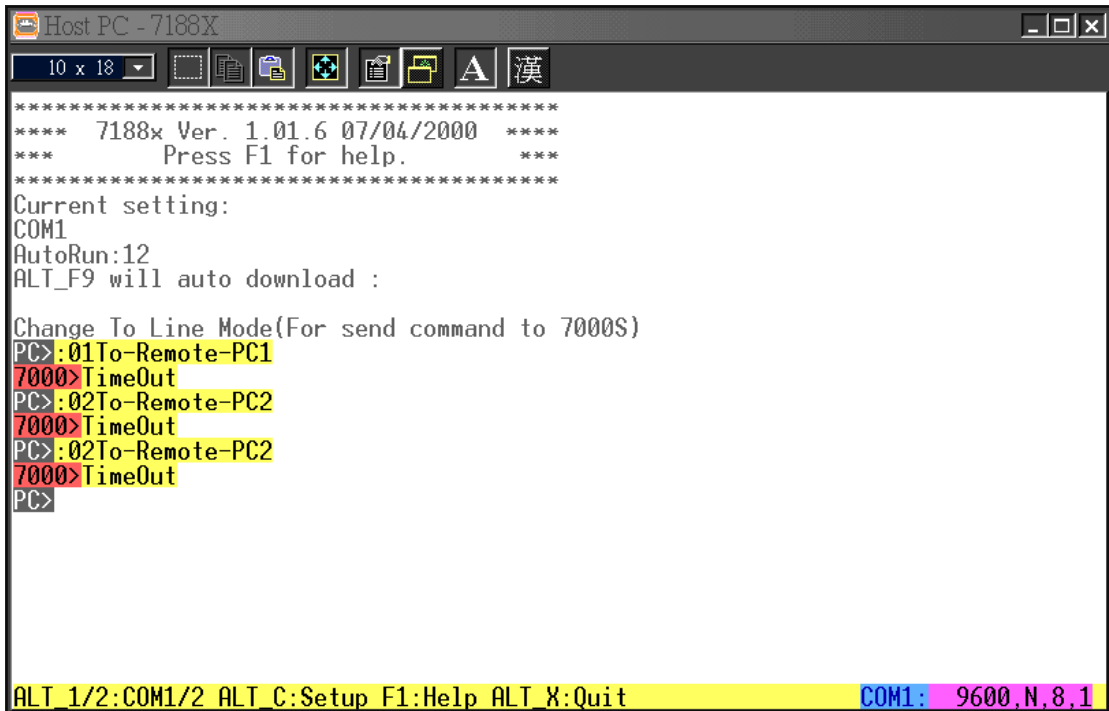

```
Host PC - 7188X
10 x 18
*****
**** 7188x Ver. 1.01.6 07/04/2000 ****
**** Press F1 for help. ****
*****
Current setting:
COM1
AutoRun:12
ALT_F9 will auto download :

Change To Line Mode(For send command to 7000S)
PC>:01To-Remote-PC1
7000>TimeOut
PC>:02To-Remote-PC2
7000>TimeOut
PC>:02To-Remote-PC2
7000>TimeOut
PC>
ALT_1/2:COM1/2 ALT_C:Setup F1:Help ALT_X:Quit COM1: 9600,N,8,1
```

The screen on Remote-PC-2 will show as follows:

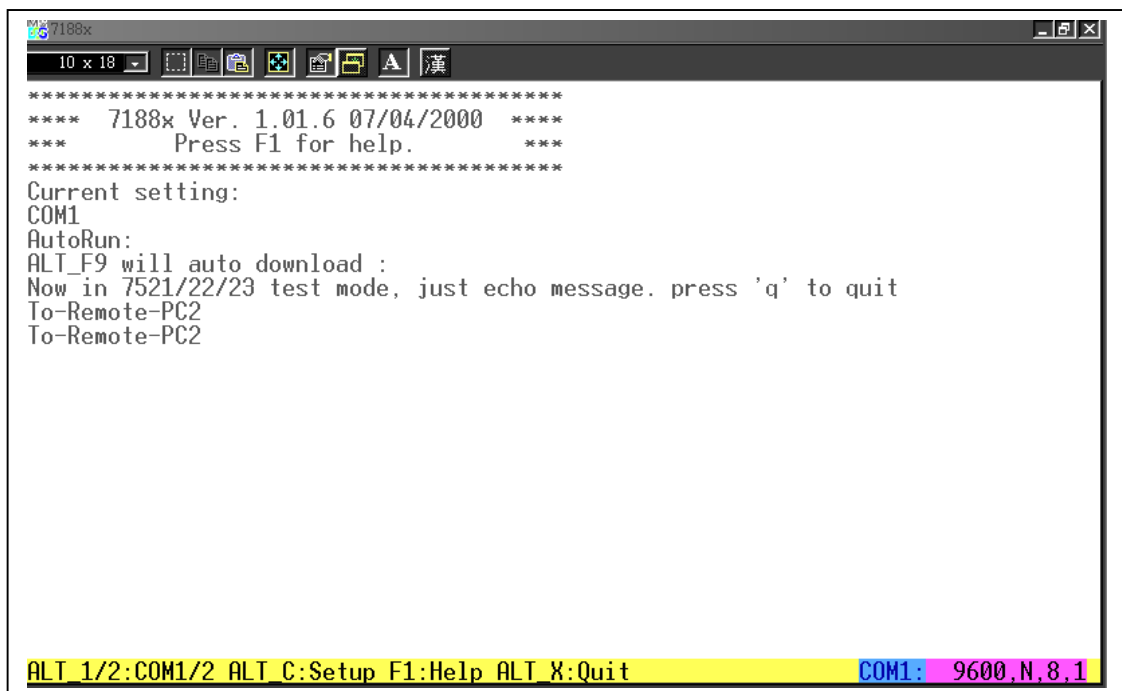

```
7188x
10 x 18
*****
**** 7188x Ver. 1.01.6 07/04/2000 ****
**** Press F1 for help. ****
*****
Current setting:
COM1
AutoRun:
ALT_F9 will auto download :
Now in 7521/22/23 test mode, just echo message. press 'q' to quit
To-Remote-PC2
To-Remote-PC2

ALT_1/2:COM1/2 ALT_C:Setup F1:Help ALT_X:Quit COM1: 9600,N,8,1
```

1.5 Downloading New Firmware to 7521

Step 1: connect the 7521 to the RS-485 networking as follows:

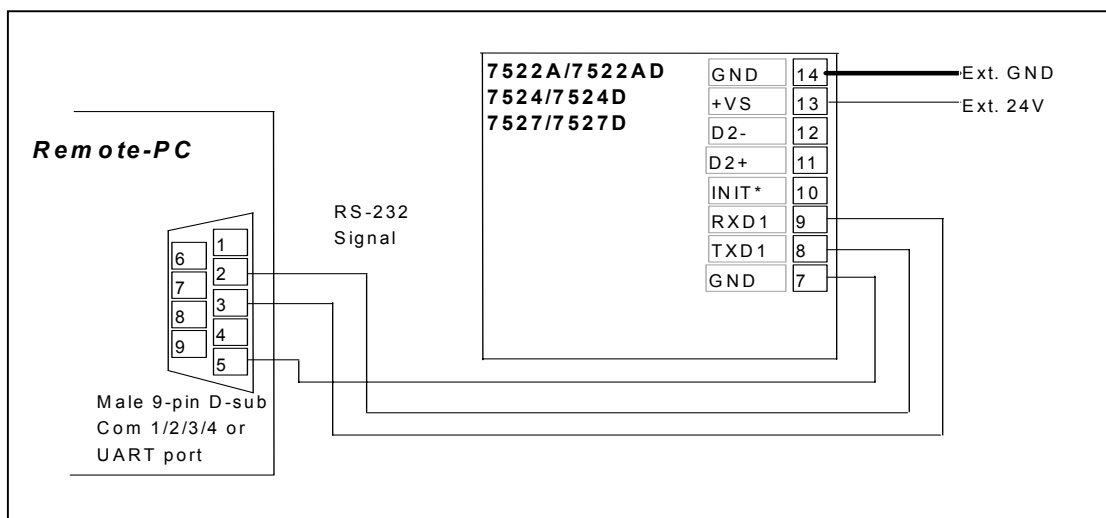
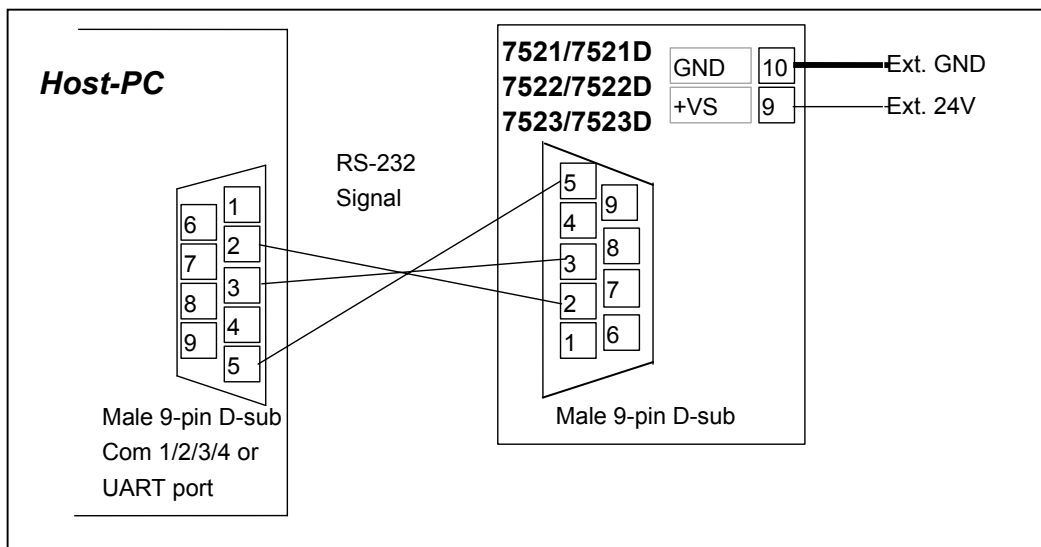
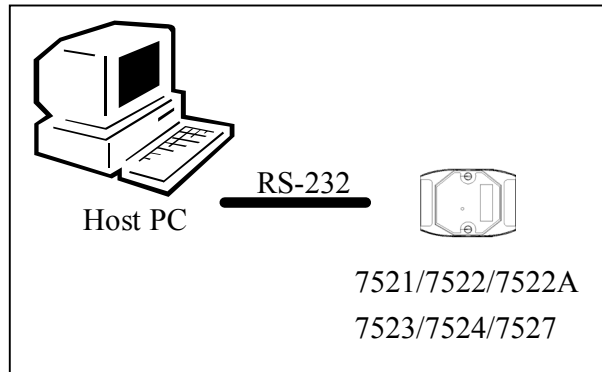

Step 2: Connect DI1/INIT* to GND

Step 3: Go to the directory of 7521/7522/7523 driver in the host computer & execute 7188x.exe

Step 4: refer to Step 3~Step7 of Quick Star1 to change the configuration to 115200,N,8,1

Key in:dir&Enter-Key and the screen will show as follows:

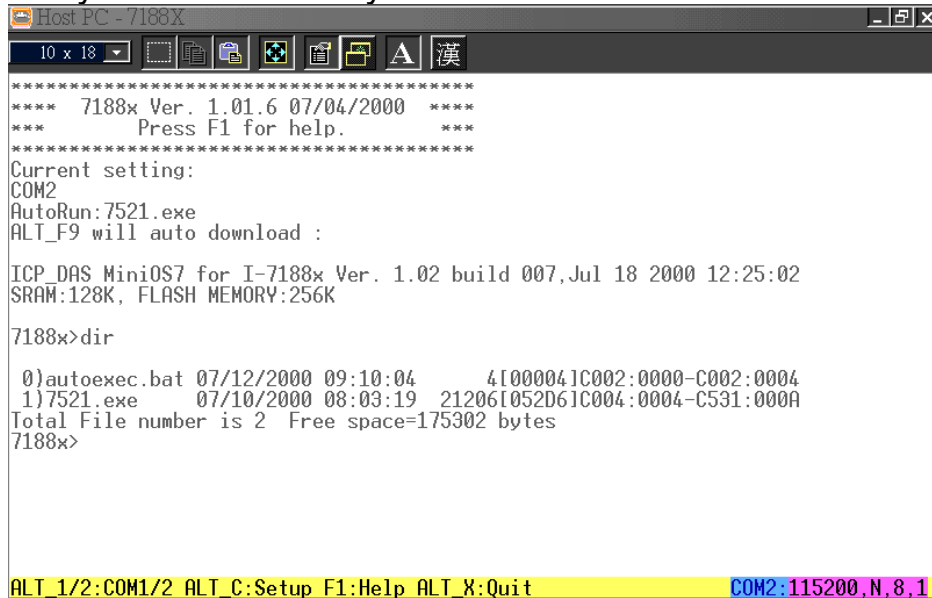

```
Host PC - 7188X
10 x 18
*****
*** 7188x Ver. 1.01.6 07/04/2000 ***
*** Press F1 for help. ***
*****
Current setting:
COM2
AutoRun:7521.exe
ALT_F9 will auto download :
ICP_DAS MiniOS7 for I-7188x Ver. 1.02 build 007,Jul 18 2000 12:25:02
SRAM:128K, FLASH MEMORY:256K
7188x>dir
 0)autoexec.bat 07/12/2000 09:10:04      4[000041C002:0000-C002:0004
 1)7521.exe      07/10/2000 08:03:19 21206[052D61C004:0004-C531:000A
Total File number is 2 Free space=175302 bytes
7188x>
ALT_1/2:COM1/2 ALT_C:Setup F1:Help ALT_X:Quit COM2:115200,N,8,1
```

Step 5: Key-in **load** & Enter-KEY

Press Alt-E

Key-in **7521.exe**

Then the MiniOs7 will download 7521.exe from the host –PC to the module. After the download operation, the screen shows as follows:

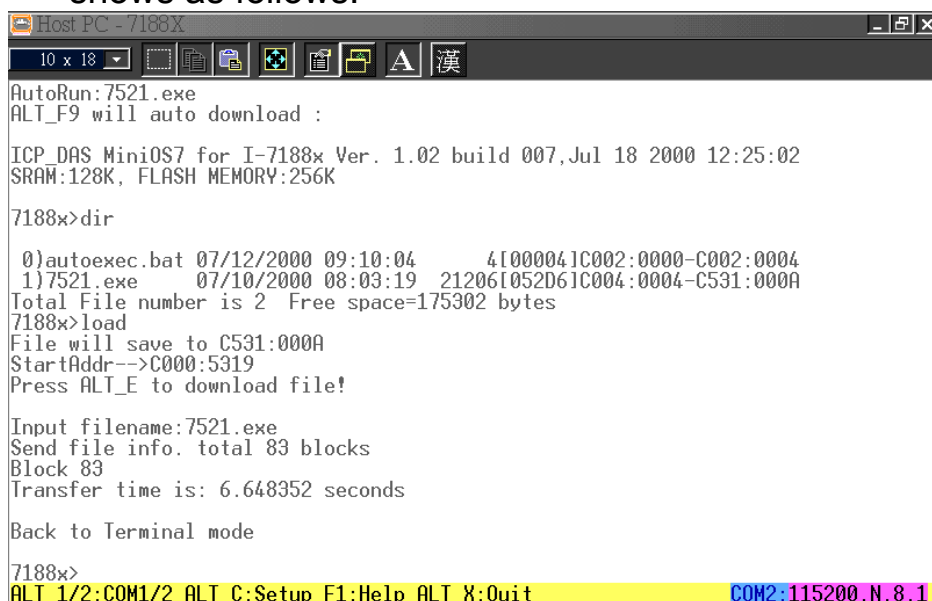

```
Host PC - 7188X
10 x 18
AutoRun:7521.exe
ALT_F9 will auto download :
ICP_DAS MiniOS7 for I-7188x Ver. 1.02 build 007,Jul 18 2000 12:25:02
SRAM:128K, FLASH MEMORY:256K
7188x>dir
 0)autoexec.bat 07/12/2000 09:10:04      4[000041C002:0000-C002:0004
 1)7521.exe      07/10/2000 08:03:19 21206[052D61C004:0004-C531:000A
Total File number is 2 Free space=175302 bytes
7188x>load
File will save to C531:000A
StartAddr-->C000:5319
Press ALT_E to download file!
Input filename:7521.exe
Send file info. total 83 blocks
Block 83
Transfer time is: 6.648352 seconds
Back to Terminal mode
7188x>
ALT_1/2:COM1/2 ALT_C:Setup F1:Help ALT_X:Quit COM2:115200,N,8,1
```

Step 6 : If Step 5 fails, please use the del command to delete all files in 7521/7522/7523. Then download autoexec.bat & 7521.exe(7522.exe, 7523.exe) to the module.

Key-in **del** & Enter-KEY

The MiniOS7 will prompt you to confirm deletion of files.

Key-in **Y** & Enter-KEY

Key-in **dir** & Enter-KEY

The MiniOS7 will show you there are no files in the controller (total file number is 0).

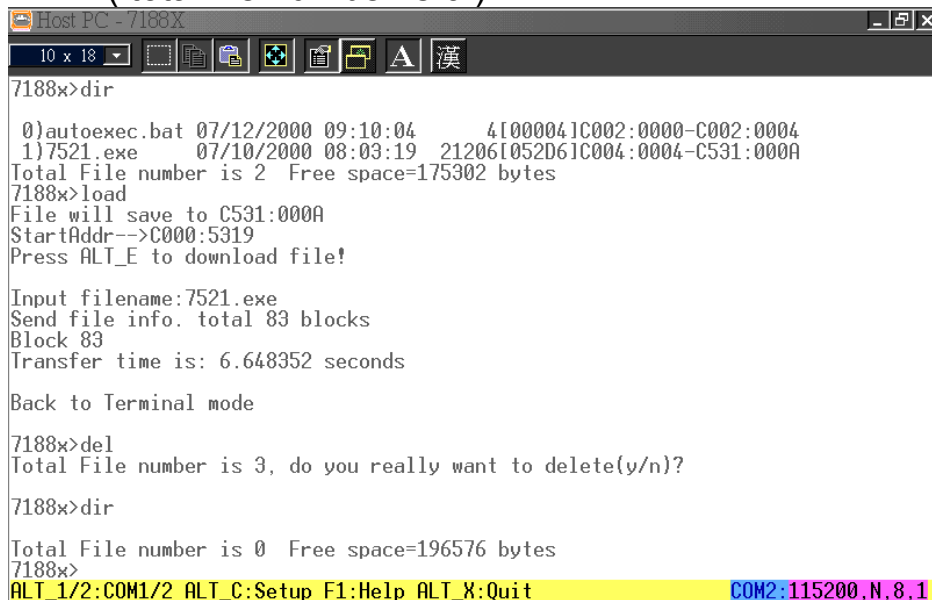

```
Host PC - 7188X
10 x 18
7188x>dir
 0)autoexec.bat 07/12/2000 09:10:04      4[00004]C002:0000-C002:0004
 1)7521.exe     07/10/2000 08:03:19  21206[052D6]C004:0004-C531:000A
Total File number is 2 Free space=175302 bytes
7188x>load
File will save to C531:000A
StartAddr-->C000:5319
Press ALT_E to download file!

Input filename:7521.exe
Send file info. total 83 blocks
Block 83
Transfer time is: 6.648352 seconds

Back to Terminal mode

7188x>del
Total File number is 3, do you really want to delete(y/n)?

7188x>dir

Total File number is 0 Free space=196576 bytes
7188x>
ALT_1/2:COM1/2 ALT_C:Setup F1:Help ALT_X:Quit COM2:115200,N,8,1
```

refer to Step 5, download autoexec.bat & 7521.exe, the screen will show as follows:

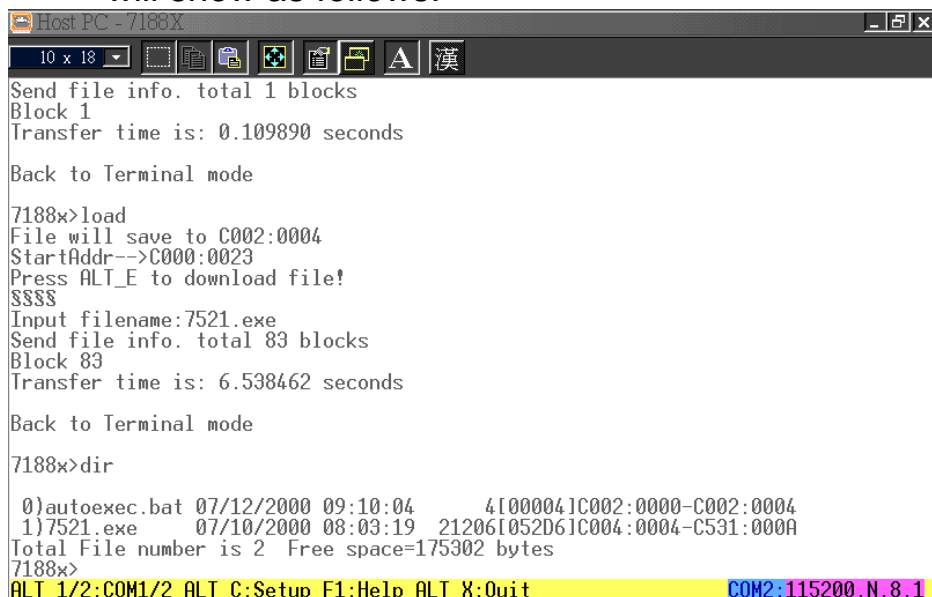

```
Host PC - 7188X
10 x 18
Send file info. total 1 blocks
Block 1
Transfer time is: 0.109890 seconds

Back to Terminal mode

7188x>load
File will save to C002:0004
StartAddr-->C000:0023
Press ALT_E to download file!
$$$$
Input filename:7521.exe
Send file info. total 83 blocks
Block 83
Transfer time is: 6.538462 seconds

Back to Terminal mode

7188x>dir

 0)autoexec.bat 07/12/2000 09:10:04      4[00004]C002:0000-C002:0004
 1)7521.exe     07/10/2000 08:03:19  21206[052D6]C004:0004-C531:000A
Total File number is 2 Free space=175302 bytes
7188x>
ALT_1/2:COM1/2 ALT_C:Setup F1:Help ALT_X:Quit COM2:115200,N,8,1
```

Step 7: disconnect the DI1/INIT* pin from GND & power-off then power-on the 7521/7522/7523.The MiniOS7 will auto execute the new firmware.

1.6 Typical Applications

Application1: Addressable RS-232 Controller(Command Type)

- There is a unique address for every 7521.
- Host-PC sends commands to all 7521 first
- The destination-7521 will pass commands to its local RS232 device
- Then, the 7521 sends back the response of the RS232 device to Host-PC
- Refer to 7521.c for source code of firmware

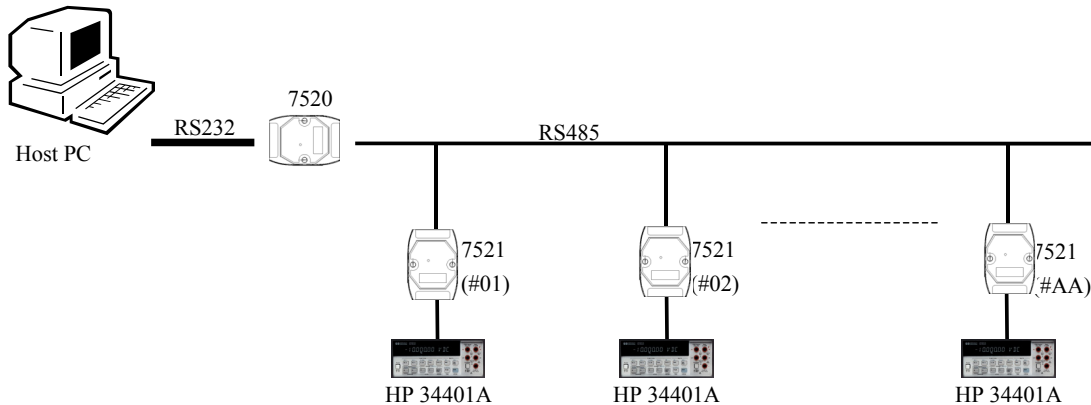

Application2: Addressable RS-232 Controller(Null-command Type)

- The barcode-reader can scan barcode anytime, the 7521 will store these barcodes in the internal buffer(1K bytes)
- Host-PC sends null-command to all 7521 first. The destination-7521 will check its internal buffer. If there is any barcode in buffer, then 7521 will send back one barcode to Host-PC.
- Host-PC can send more null-commands to read all barcodes stored in the internal buffer of the 7521
- Refer to 7521.c for source code of firmware

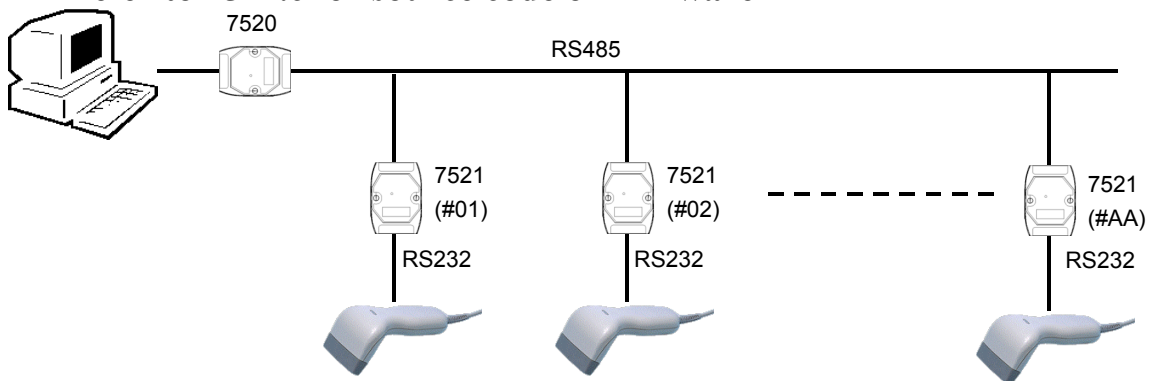

Application3: Addressable RS-232 Controller (Dual-channel)

- There is a unique address, AA, for every 7522.
- Every 7522 can support two RS232 devices, AA & AA+1
- Host-PC sends commands to all 7522 first
- The destination-7522 will pass commands to its local RS232 device 1 or RS232 device 2.
- Then, the 7522 sends back the response of the RS232 device to Host-PC
- The RS232 device can be used for command-type(application 1) or null-command type(application 2)
- Refer to 7522.c for source code of firmware

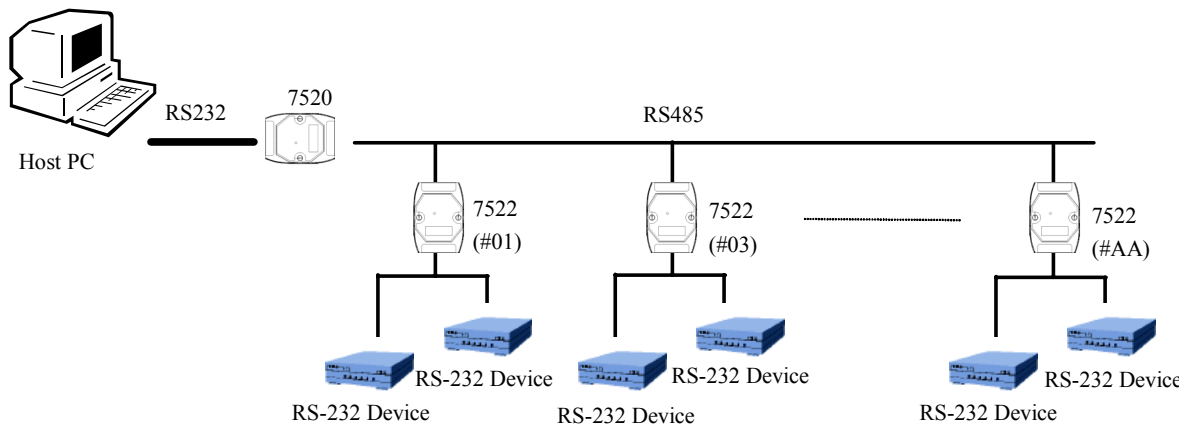

Application4: Addressable RS-232 Controller(Three-channel)

- There is a unique address, AA, for every 7523.
- Every 7523 can support three RS232 devices, AA, AA+1 & AA+2
- Host-PC sends commands to all 7523 first
- The destination-7523 will pass commands to its local RS232 device 1, RS232 device 2 or RS232 device 3.
- Then, the 7523 sends back the response of the RS232 device to Host-PC
- The COM4 of the 7523 can support 1/2 stop-bit, so it can support two stop-bit device such as HP34401A.
- The RS232 device can be used for command-type(application 1) or null-command type(application 2)
- Refer to 7523.c for source code of firmware

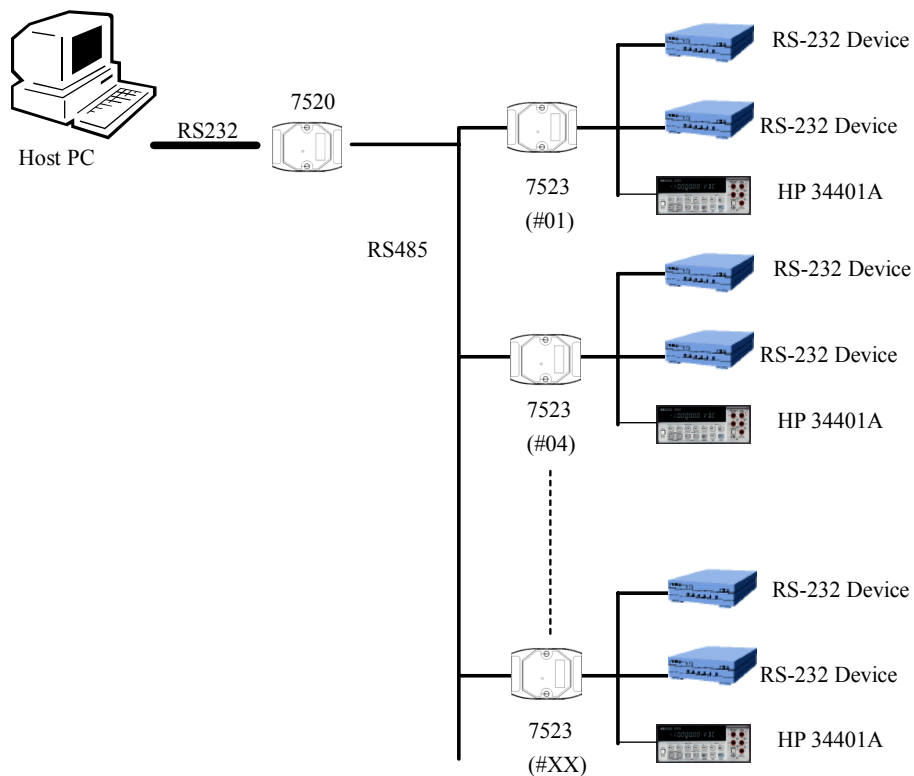

Application5: Addressable RS-232 Controller(Four-channel)

- There is a unique address, AA, for every 7524.
- Every 7524 can support three RS232 devices, AA, AA+1, AA+2 & AA+3
- Host-PC sends commands to all 7524 first
- The destination-7524 will pass commands to its local RS232 device 1, RS232 device 2, RS232 device 3 or RS232 device 4.
- Then, the 7524 sends back the response of the RS232 device to Host-PC
- The COM3 & COM4 of the 7524 can support 1/2 stop-bit, so it can support two stop-bit device such as HP34401A.
- The RS232 device can be used for command-type(application 1) or null-command type(application 2)
- Refer to 7524.c for source code of firmware

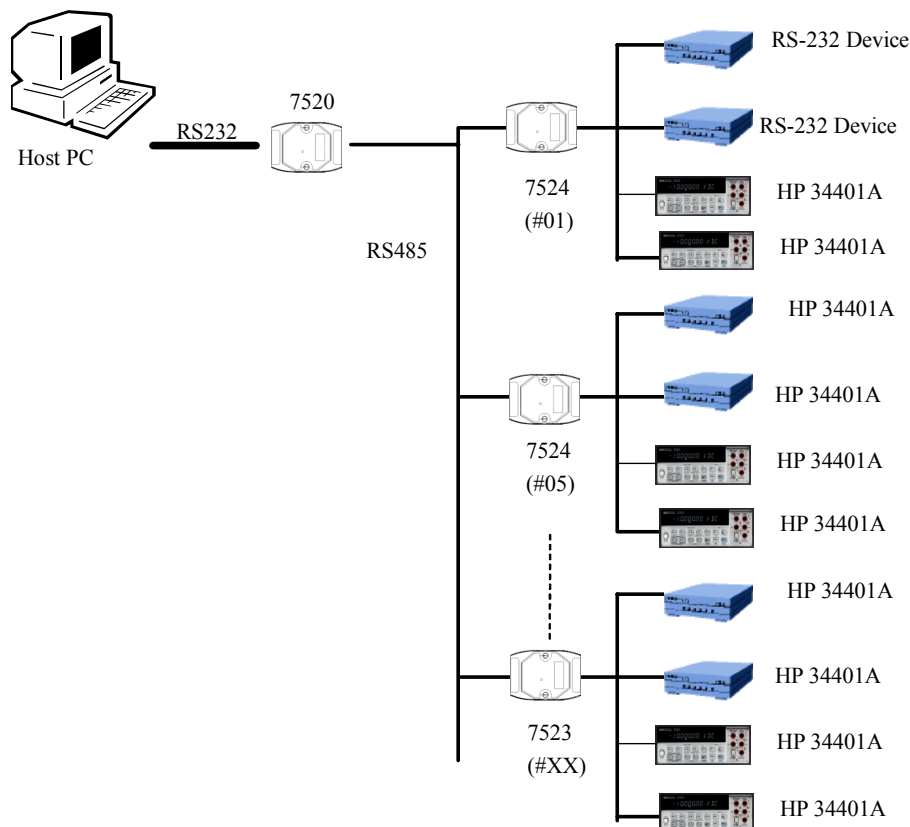

Application6: Addressable RS-232 Controller (Seven-channel)

- There is a unique address, AA, for every 7527.
- Every 7523 can support three RS232 devices, AA, AA+1, AA+2, AA+3, AA+4, AA+5, AA+6 & AA+7
- Host-PC sends commands to all 7527 first
- The destination-7527 will pass commands to its local RS232 device 1, RS232 device 2, RS232 device 3, RS232 device 4, RS232 device 5, RS232 device 6 or RS232 device 7.
- Then, the 7527 sends back the response of the RS232 device to Host-PC
- The COM3, COM4, COM5, COM6 & COM7 of the 7527 can support 1/2 stop-bit, so it can support two stop-bit device such as HP34401A.
- The RS232 device can be used for command-type(application 1) or null-command type(application 2)
- Refer to 7527.c for source code of firmware

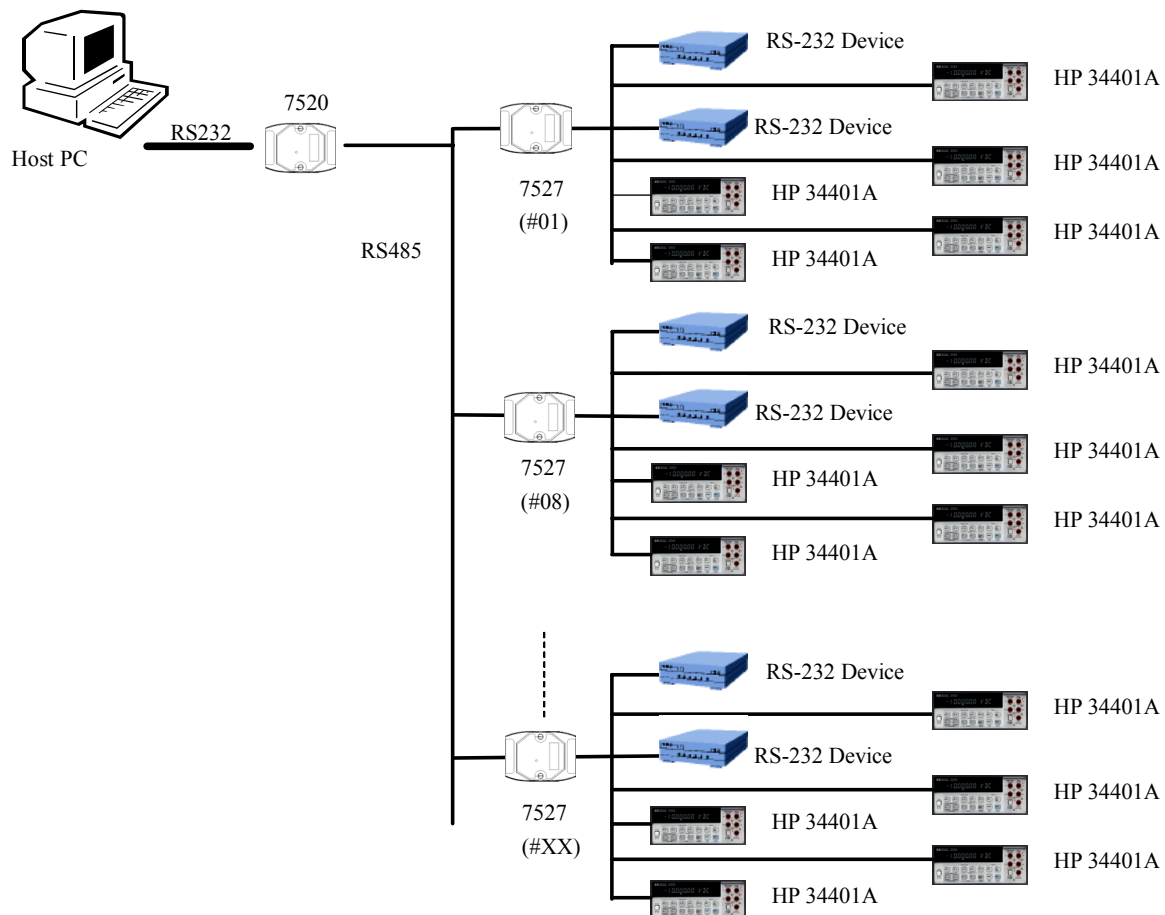

Application7: Real time D/I Monitoring & D/O Alarm (Master type)

- Refer to applications 1 & 2 for more information.
- The 7521 will scan & analyze the onboard D/I, if the D/I states a match with the alarm states, the onboard D/O will drive the alarm device for alarm or safety control.
- All control operations of D/I & D/O are done by the 7521. The host-PC only reads the values of D/I & D/O for system monitoring.
- Refer to 7521ODM1.c for the source code of firmware

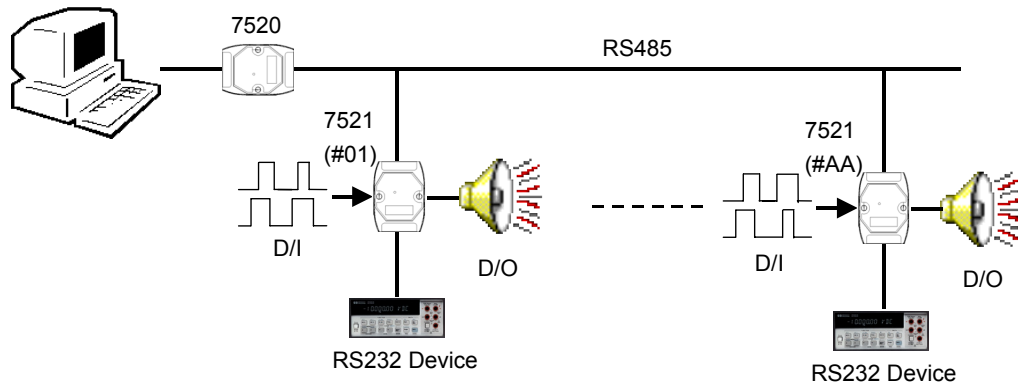

Application8: Real time A/D Monitoring & D/A Control(Master type)

- Refer to applications 1 & 2 for more information.
- The X301 supports one A/D & one D/A & it can be installed into the 7521. The 7521+X301 can read & analyze the A/D in real time. The output of D/A is controlled based on the value of A/D.
- All control operations of A/D & D/A are done by the 7521. The host-PC only reads the values of A/D & D/A for system monitoring.
- Refer to 7521ODM2.c for source code of firmware

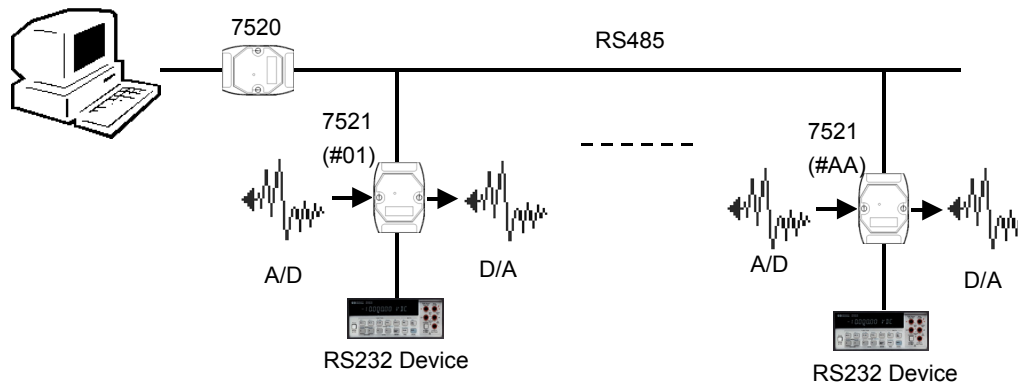

Application9: 8-channels of long time Event-counters(Master type)

- Refer to applications 1 & 2 for more information.
- The X100 supports 8-channel of D/I. The 7521+X100 can read & analyze these 8 event-counters in real time. The timing diagram of the event-counter will be latched until host-PC's clear command.
- All analysis operations are done by the 7521. The host-PC only read the timing values of the event-counter for system monitoring.
- Refer to 7521ODM3.c for source code of firmware

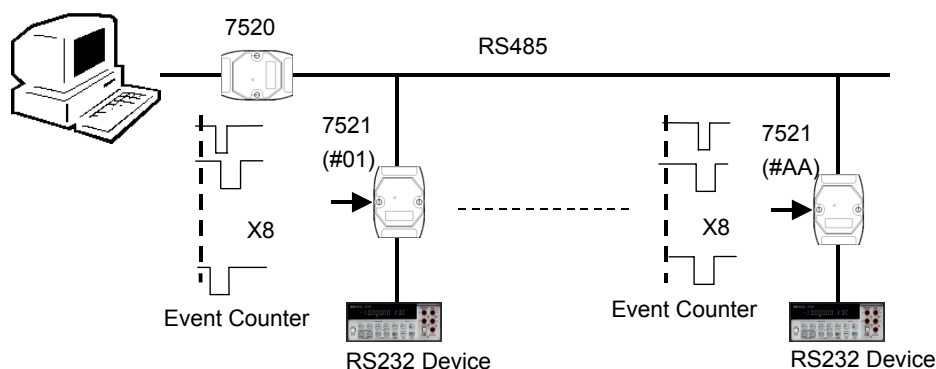

Application10: Multiplex Control(Master type)

- Refer to applications 1 & 2 for more information.
- The onboard D/O of the 7521 can drive relay directly. The onboard D/I can link to photo-sensors for event triggering. The 7521+DN-PR4 can trigger by photo-sensor & control the multiplex to select the expected analog signal.
- All control operations are done by the 7521. The host-PC can read the 3-channel A/D signals without the multiplex control.
- Refer to 7521ODM4.c for source code of firmware

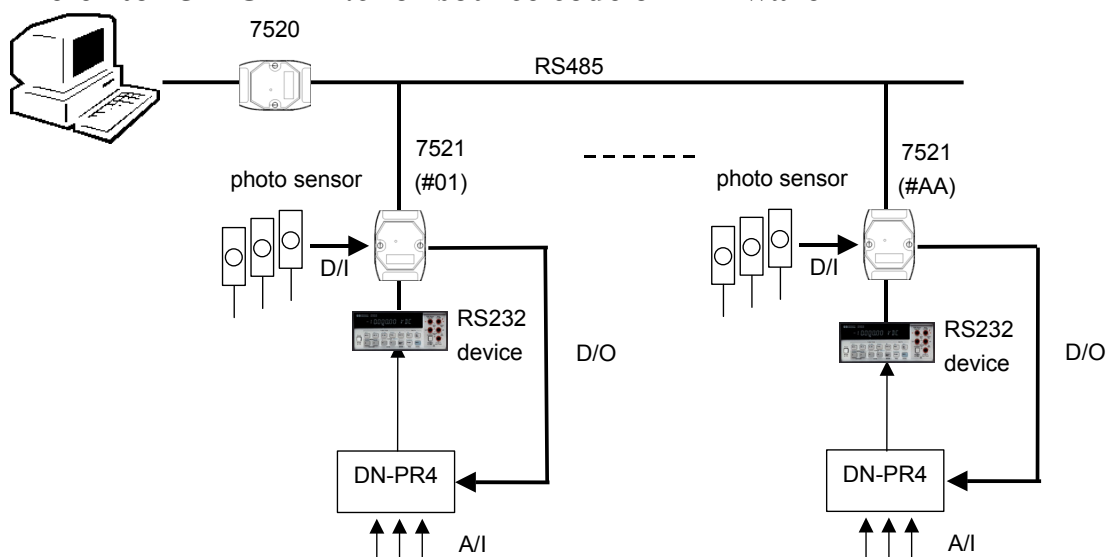

Application11: Real time Analog Signal Monitoring & Alarm Control(Master type)

- Refer to applications 1 & 2 for more information.
- The COM1 of host-PC is used as a host-485 network. Host-PC will send commands & receive responses through this RS485 network.
- The COM2 of host-PC is used as an emergency-485 network. All 7522s will automatically monitor the analog signal connected to HP34401A. If the emergency event occurs, the 7522 will send the emergency command to this RS485 network. If multi-7522s send emergency commands to host-PC at the same time, these 7522s will re-send emergency commands to host-PC until confirmation from host-PC.
- All analysis operations are done by the 7522. The host-PC only reads the analog values for system monitoring.
- Refer to 7522ODM5.c for source code of firmware

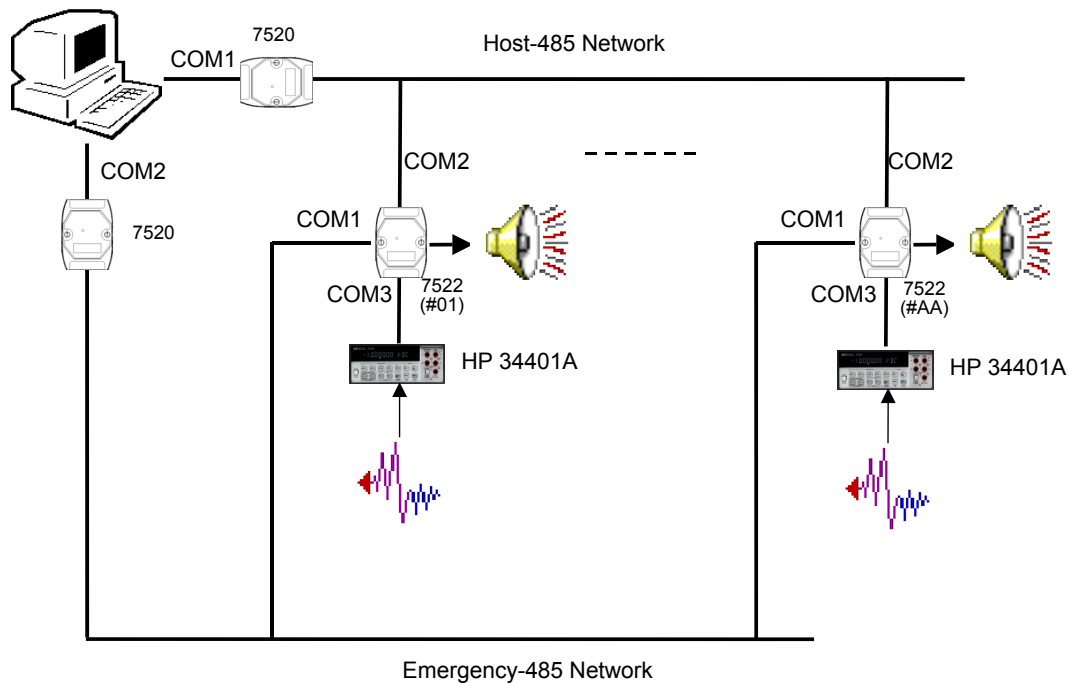

2. Connecting to the HP34401A

2.1 The 7521 & the HP34401A

The stop-bit of the HP34401A must be two stop-bit. The COM1 of the 7521, 7522 & 7523 can support 1 stop-bit only. So COM1 cannot link to the HP34401A. That is to say, the 7521 can not link to the HP34401A.

The COM3 of the 7522 & COM3/COM4 of the 7523 can support 2 stop-bit, so they can link to the HP34401A. The 7522 can link to one HP34401A. The 7523 can link to two HP34401As. Refer to Sec. 2.2 ~ Sec. 2.6 for more information.

2.2 The PC & the HP34401A

APC can link to the HP34401A by COM1 or COM2 as follows:

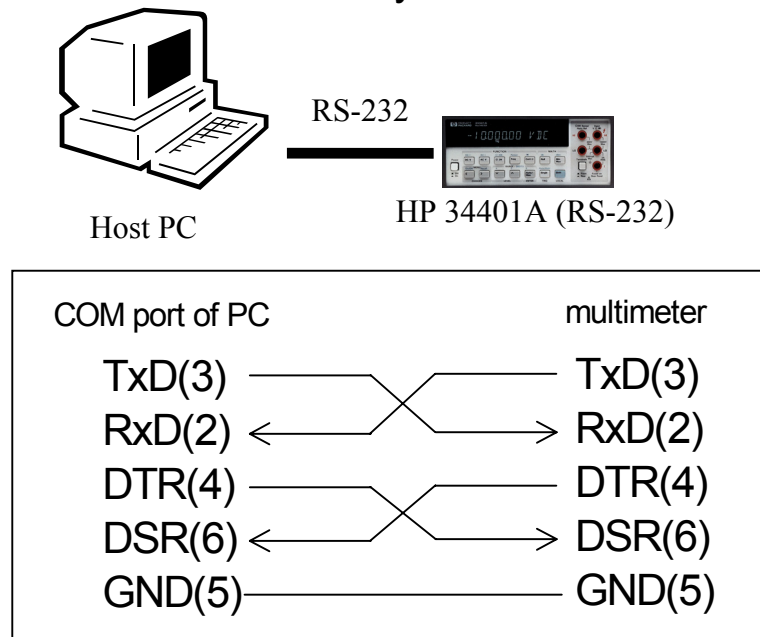

The default setting of the HP34401A are given as follows:

- Baud rate=9600
- Data-bit=7
- Parity-bit=EVEN
- Stop-bit=2
- TXD: send command to RS232-HOST
- RXD: receive command from RS232-HOST
- DTR: HP34401A set it active-HIGH to enable RS232-HOST for sending commands
- DSR: RS232-HOST set it active-HIGH to enable the HP34401A for sending results back to RS232-HOST

The demo program, hp34401a.c, is designed so that a PC can connect to a HP34401A. Refer to the companion CD for the source code of hp34401a.c. The flow chart of hp34401a.c is given as follows:

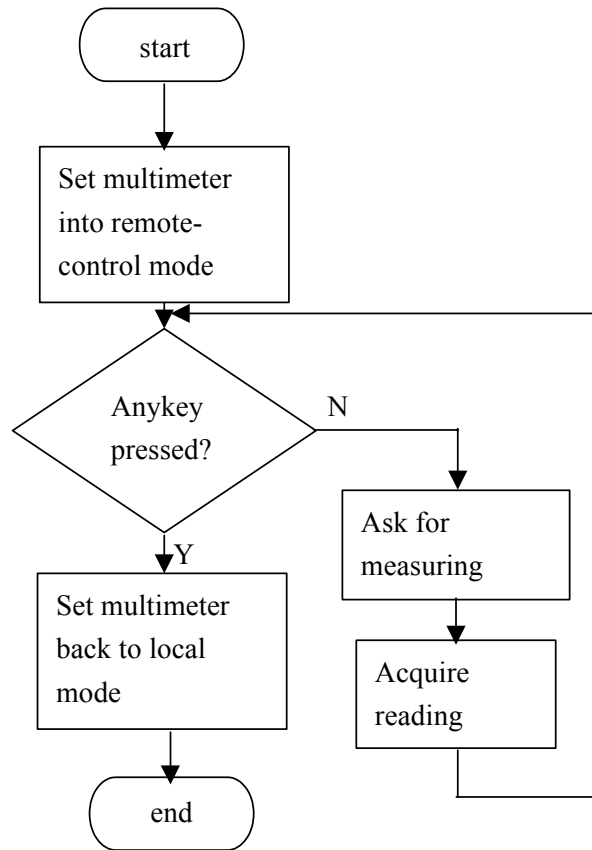

Note: the COM port of PC should be 16550 compatible.

2.3 A Single-7522 & Single-HP34401A

The following diagram shows one PC connected to a remote-HP34401A in the RS485 network. The 7520 is used to convert the PC's RS232 signal to RS485 signal. The 7522 is used as a "Addressable RS232 converter" for the HP34401A (there is no address setting in the HP34401A).



圖 5

The demo program, `hp22_1.c`, is designed so that the HOST-PC can link to a remote-HP34401A. Refer to the companion CD for the source code of `hp22_1.c`. The key points of `hp22_1.c` are given as follows:

- RTS3 of COM3 must be set active-HIGH first to enable the HP34401A.
- The flow chart of `hp22_1.c` is given as follows:

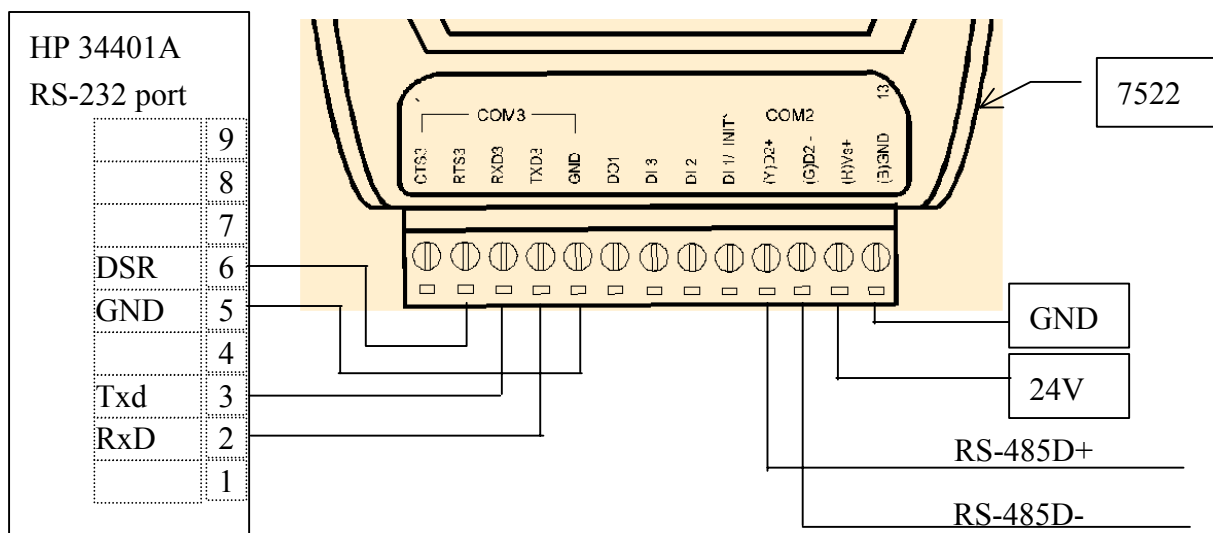
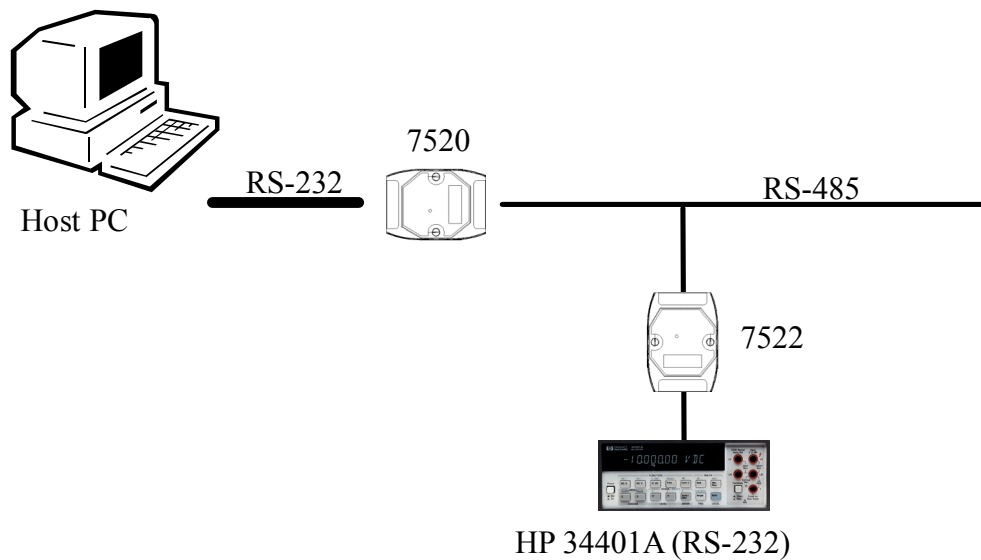
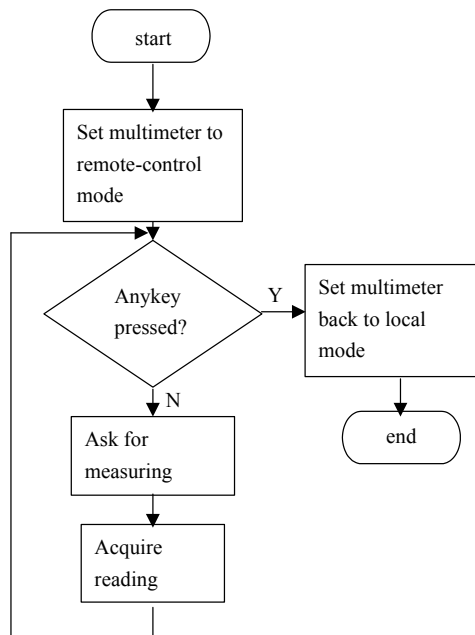

Note: the COM port of PC should be 16550 compatible.

The source code of `hp22_1.c` is given as follows:

```

#include "com.h"
#include <conio.h>
#include <stdio.h>
#include <string.h>
#include <dos.h>
#include <time.h>
/*=====
                               Transmit one char to ComNo
===== */
int TxCharCOM(int ComNo, char ch)
{
    clock_t c1, c2;
    int time_wait;
    int ComBase;
    if(ComNo == COM1) ComBase = Com1Base; /* Set base address */
    else if(ComNo == COM2) ComBase = Com2Base;
    c1 = clock();

```

```

time_wait=0;
while(!(inportb(LSR) & 0x20)) {          /* Wait until line ready */
    c2 = clock();
    if(c1 != c2) {
        c1 = c2;
        time_wait++;
    }
    if(time_wait > COM_MAX_RX_WAIT_TIME) return(RxTimeOut);
}
outportb(TxD, ch);                      /* Output char */
return(TxOK);
}
/*=====
                               Initial Port of ComNo
===== */
int InitCOM(int ComNo, unsigned long int BaudRate, int DataFormat)
{
    int br, ComBase;
    char MSB, LSB;
    if(ComNo == COM1) ComBase = Com1Base;
    else if(ComNo == COM2) ComBase = Com2Base;
    br = 115200L/BaudRate;
    MSB = (br&0xff00)>>8;
    LSB = br&0xff;
    disable();
    outportb(LCR, 0x80);                  /* Set baudrate */
    outportb(DLL, LSB);
    outportb(DLH, MSB);
    outportb(LCR, DataFormat);           /* Set DataFormat */
    outportb(FCR,0xc1);                  /*enable FIFO, 14 bit buffer*/
    outportb(IER, 0);                    /* Disable all Interrupt */
    inportb(LSR);
    inportb(RxD);
    outportb(MCR, 0x09);
    outportb(IER, 0x01);                  /* Int. while receive data */
    outportb(TxD, 0x0d);
    enable();
    return(0);
}
/*=====
                               Reset ReceiveQueue of ComNo
===== */
/*=====
                               Polling a char from ComNo
                               Return RxOK
                               RxTimeOut
===== */
int PollRxChar(int ComNo, char* ch)

```

```

{
  clock_t c1, c2;
  int ComBase, wait_time;
  if(ComNo==COM1) ComBase = Com1Base;
  else ComBase = Com2Base;
  wait_time=0;
  c1 = clock();
  while((inportb(LSR) & 0x0f)!=0x01) {
    c2 = clock();
    if(c1 != c2) {
      c1 = c2;
      wait_time++;
    }
  }
  if(wait_time > COM_MAX_RX_WAIT_TIME) return(RxTimeOut);
};
*ch=inportb(RxD);
return(RxOK);
}
/*=====
                                     Wait a clock tick
===== */
void WaitClock(int count)
{
  int temp;
  clock_t c1, c2;
  for(temp=0; temp<count; temp++) {
    c1 = clock();
    c2 = clock();
    while(c2==c1) {
      c2 = clock();
    }
  }
}
ComSetting com[2];
/*=====
                                     Initial HP in serial port
===== */
void InitHP(int ComNo)
{
  com[ComNo].ComNo = ComNo;
  com[ComNo].BaudRate = 9600L;
  com[ComNo].DataFormat = Data8bit + NonParity + Stop1bit; //RS-485
setting
  com[ComNo].Checksum = CHKSUMdisable;
  OpenCOM(ComNo);
  HPSendCommand(ComNo, ":02SYST:REM");
  HPSendCommand(ComNo, ":02*CLS");
  WaitClock(18);
}

```

```

}
/*=====
                                Close HP in serial port
===== */
void CloseHP(int ComNo)
{
    HPSendCommand(ComNo, ":02*CLS");
    HPSendCommand(ComNo, ":02SYST:LOC");
    CloseCOM(ComNo);
}
/*=====
                                Send Command to HP in serial port
===== */
int HPSendCommand(int ComNo, char *str)
{
    int i;
    unsigned char chk=0;
    for(i=0; str[i]!=0; i++)
    {
        if(TxCharCOM(com[ComNo].ComNo, str[i]) == TxTimeOut)
return(TxTimeOut);
        chk += str[i];
    }
    if(TxCharCOM(com[ComNo].ComNo, 0x0d)==TxTimeOut)
return(TxTimeOut);    //RS-485 setting
    return(TxOK);
}
/*=====
                                Receive Command to HP in serial port
===== */
int HPReceiveCommand(int ComNo, char *str)
{
    int end_of_rx=0, i=0;
    for(i=0; !end_of_rx; i++) {
        str[i] = 0;
        switch(PollRxChar(com[ComNo].ComNo, str+i)) {
            case RxOK :
                if( str[i] == 0x0d) //RS-485 setting
                {
                    str[i] = 0;
                    end_of_rx = 1;
                }
                break;
            case RxTimeOut :
                return(RxTimeOut);
            case RxOverflow :
                return(RxOverflow);
        }
    }
}

```

```

    }
    i--;
    return(i);
}
/*=====
                                Read analog value from HP
===== */
int ReadHP(int ComNo, double *AI)
{
    int ret;
    float A;
    char str1[80] ;
    HPSendCommand(ComNo, ":02READ?");
    ret = HPReceiveCommand(ComNo, str1);
    if(ret < 0) return(ret);
    *AI = atof(str1);
    return(HP_OK);
}
/*=====
                                Initial COM port
===== */
int OpenCOM(int ComNo)
{
    InitCOM(com[ComNo].ComNo, com[ComNo].BaudRate,
com[ComNo].DataFormat);
    return(0);
}
/*=====
                                Close/Restore COM port
===== */
int CloseCOM(int ComNo)
{
    return(0);
}
int ShowErrorCode(int error_code);
int main(char argc, char* argv[])
{
    int ret, ComNo;
    double AI;
    int Bye=0;
    int i;
    char str[80];
    if(argc!=2) {
        printf("No COM port assigned\n");
        printf(" Use HP 1 for COM1, HP2 for COM2");
        exit(0);
    }
    if(argv[1][0] == '1') {

```

```

    printf("Connect HP in COM1\n");
    ComNo = COM1;
}
else if(argv[1][0] == '2') {
    printf("Connect HP in COM2\n");
    ComNo = COM2;
}
else {
    printf(" Use HP 1 for COM1, HP2 for COM2");
    exit(0);
}
InitHP(ComNo);
while(!Bye)
{
    if(kbhit())
    {
        Bye=1;
    }
    if(HPSendCommand(ComNo, ":02READ?")<0)
        ShowErrorCode(ret);
    if((ret=HPReceiveCommand(ComNo, str))>0)
        printf("\nreading=%sV",str);
    else ShowErrorCode(ret);
    WaitClock(12);
}
CloseHP(ComNo);
return(0);
}
int ShowErrorCode(int error_code)
{
    printf("\n");
    switch(error_code) {
        case RxOK :    printf("RxOK      ");        break;        /* 1 */
        case TxOK :    printf("TxOK      ");        break;        /* 2 */
        case HP_OK :   printf("HP OK     ");        break;        /* 3 */
        case TxTimeOut :printf("TxTimeOut ");    break;        /* -10 */
        case RxTimeOut :printf("RxTimeOut ");    break;        /* -11 */
        case RxOverFlow :printf("RxOverFlow ");    break;        /* -12 */
        default :      printf("error=%d ", error_code);break;
    }
    return(0);
}

```

2.4 Multi-7522 & Multi-HP34401A

The following diagram shows one PC connected to a multiple, remote-HP34401As in the RS485 network. The 7520 is used to convert the PC's RS232 signal to a RS485 signal. The 7522 is used as a "Addressable RS232 converter" for the HP34401A (there is no address setting in HP34401A).

Every 7522 has a unique address in the RS485 network. Every hp34401A shares the same address-range with its 7522, so every HP34401A has a unique address in this configuration.

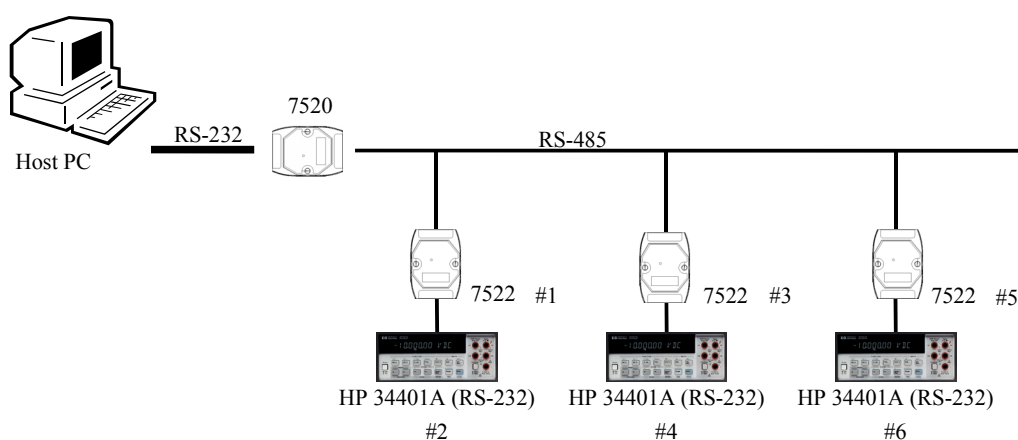

The demo program, `hp22_m.c`, is designed so that the HOST-PC can link to the remote-HP34401A. Refer to the companion CD for the source code of `hp22_m.c`. The key points of `hp22_m.c` are given as follows:

- The configuration of 7522 is given as follows:

	COM2(485)	COM3(232)
baud rate	9600(default)	9600(default)
Parity	None(default)	Even
data	8(default)	7
stop bit	1(default)	2

- All RTS3 of COM3 must be set active-high first to enable HP34401A.
- The address mapping of this configuration is given as follows:

No.of 7522	Address of 7522
#1	01h
#3	03h
#5	05h

No.of HP	Address of HP34401A
#2	02h
#4	04h
#6	06h

● The flow chart of hp22_m.c is given as follows:

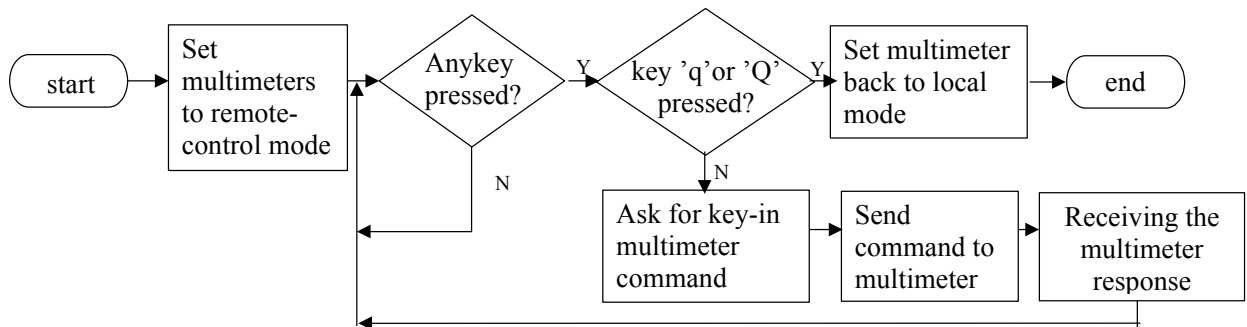

● Execution examples:

```

MS-DOS 模式 - HP22_M
10 x 18
QW   EXE   11,962  06-30-00  14:31  QW.EXE
SER   EXE   8,752   07-03-00  9:18   SER.EXE
     9 file(s) 168,925 bytes
     0 dir(s) 3,552,923,648 bytes free

F:\HP\hpdemo75>hp22_m 1
Connect 7522 net in COM1

command-> q

F:\HP\hpdemo75>hp22_m 1
Connect 7522 net in COM1

command-> :02*IDN?

T×OK
response: HEWLETT-PACKARD,34401A,0,10-5-2
command-> :04*IDN?

T×OK
response: HEWLETT-PACKARD,34401A,0,10-5-2
command-> :06READ?

T×OK
response: -4.52592200E-03
  
```

2.5 A Single-7523 & Two-HP34401A

The following diagram shows one PC connected to two remote-HP34401As in a RS485 network. The 7520 is used to convert the PC's RS232 signal to a RS485 signal. The 7523 is used as a "Addressable RS232 converter" for the HP34401A (there is no address setting in HP34401A). One 7523 can connect two HP34401As.

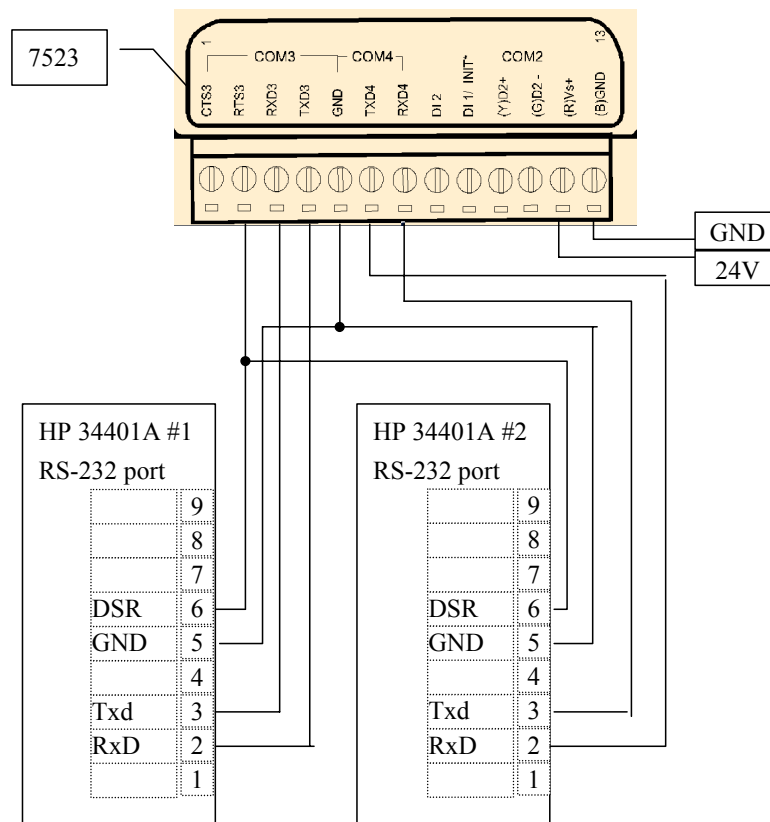
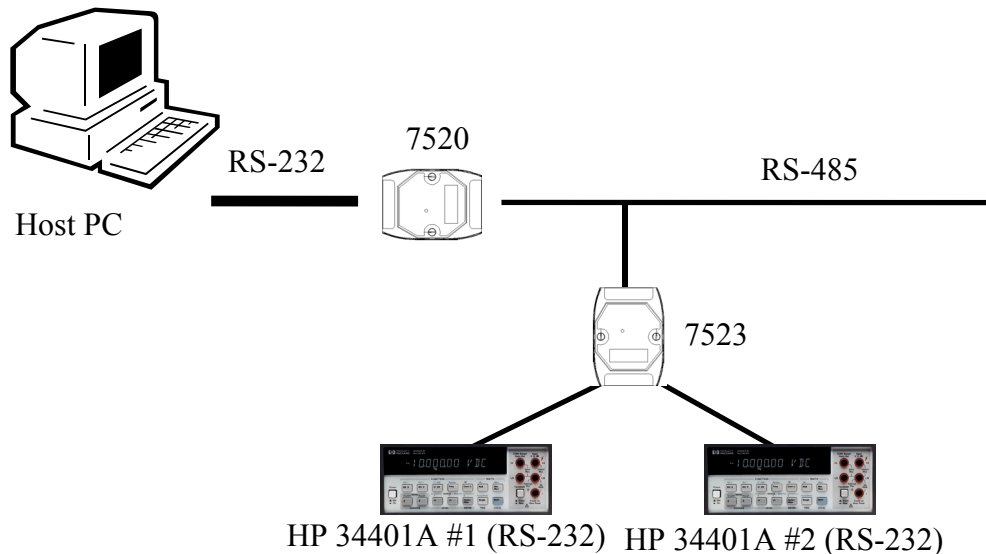

The demo program, `hp23_1.c`, is designed so that the HOST-PC can link to the remote-HP34401A. Refer to the companion CD for the source code of `hp23_1.c`. The key points of `hp23_1.c` are given as follows:

- All RTS3 of COM3 must be set active-HIGH first to enable the HP34401A.
- The COM-ports of this configuration are given as follows:

	COM2(485)	COM3(232)	COM4(232)
Baud rate	9600 (default)	9600 (default)	9600 (default)
Parity	None (default)	Even	Even
data	8 (default)	7	7
stop bit	1 (default)	2	2

- The address mapping of this configuration is given as follows:

address of 7523	Corresponding COM3 address	Corresponding COM4 address
01h	02h	03h

- The `InitHP()` and `CloseHP()` of `hp23_1.c` are given as follows:

```
void InitHP(int ComNo)
{
    com[ComNo].ComNo = ComNo;
    com[ComNo].BaudRate = 9600L;
    com[ComNo].DataFormat = Data8bit + NonParity + Stop1bit;
    com[ComNo].Checksum = CHKSUMdisable;
    OpenCOM(ComNo);

    HPSendCommand(ComNo, ":02SYST:REM");           // #1 HP
    HPSendCommand(ComNo, ":02*CLS");               // #1 HP
    HPSendCommand(ComNo, ":03SYST:REM");           // #2 HP
    HPSendCommand(ComNo, ":03*CLS");               // #2 HP
    WaitClock(18);
}

void CloseHP(int ComNo)
{
    HPSendCommand(ComNo, ":02*CLS");               // #1 HP
    HPSendCommand(ComNo, ":02SYST:LOC");           // #1 HP
    HPSendCommand(ComNo, ":03*CLS");               // #2 HP
    HPSendCommand(ComNo, ":03SYST:LOC");           // #2 HP
    CloseCOM(ComNo);
}
```

2.6 Multi-7523s & Multi-HP34401As

The following diagram shows one PC connected to multiple remote-HP34401As in a RS485 network. The 7520 is used to convert the PC's RS232 signal to a RS485 signal. The 7523 is used as a "Addressable RS232 converter" for the HP34401A (there is no address setting in HP34401A). One 7523 can connect to two HP34401As.

Every 7523 has a unique address in the RS485 network. Every HP34401A shares the same address-range with its 7523, so every HP34401A has a unique address in this configuration.

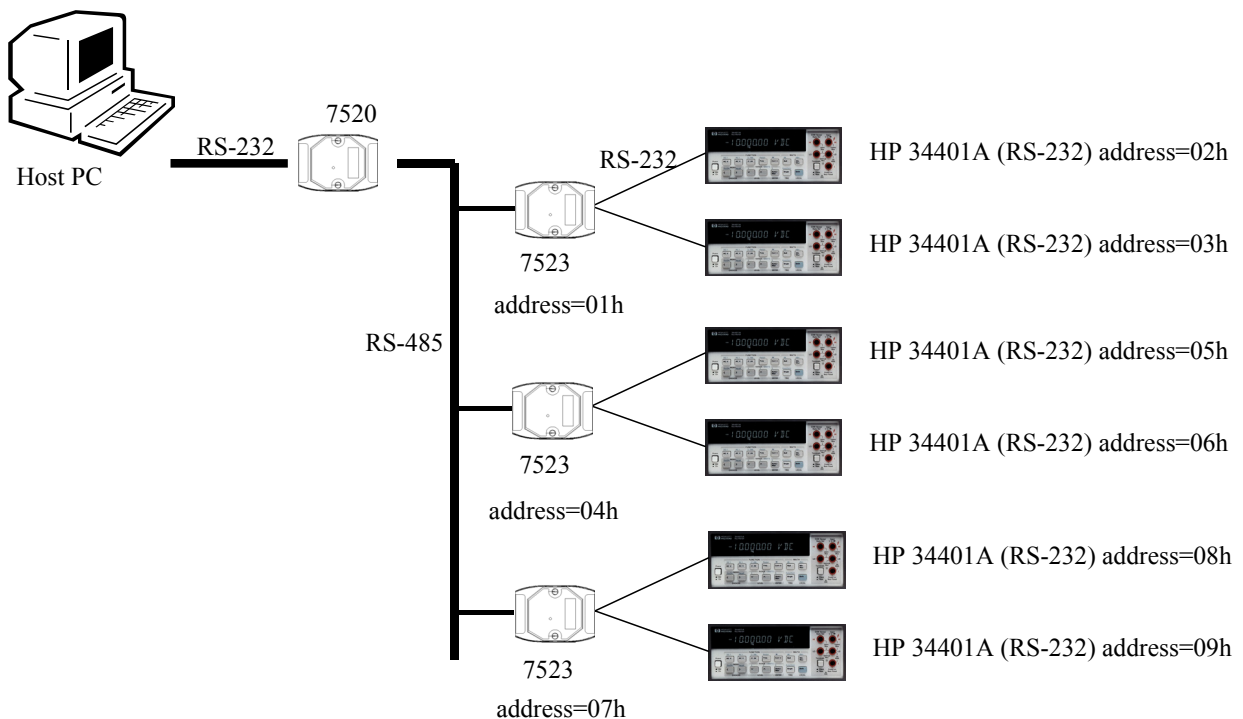

The demo program, `hp23_m.c`, is designed so that the HOST-PC can link to the remote-HP34401A. Refer to the companion CD for the source code of `hp23_m.c`. The key points of `1hp.c` are given as follows:

- All RTS3 of COM3 must be set active-HIGH first to enable the HP34401A.

● **The COM-port setting of this configuration is given as follows:**

	COM2(485)	COM3(232)	COM4(232)
baud rate	9600 (default)	9600 (default)	9600 (default)
parity	None (default)	Even	Even
data	8 (default)	7	7
stop bit	1 (default)	2	2

● **The InitHP() and CloseHP() of hp23_M.c are given as follows:**

```
void InitHP(int ComNo)
{
    com[ComNo].ComNo = ComNo;
    com[ComNo].BaudRate = 9600L;
    com[ComNo].DataFormat = Data8bit + NonParity + Stop1bit;
    com[ComNo].Checksum = CHKSUMdisable;
    OpenCOM(ComNo);

    HPSendCommand(ComNo, ":02SYST:REM"); // #1 HP
    HPSendCommand(ComNo, ":02*CLS"); // #1 HP
    HPSendCommand(ComNo, ":03SYST:REM"); // #2 HP
    HPSendCommand(ComNo, ":03*CLS "); // #2 HP
    HPSendCommand(ComNo, ":05SYST:REM"); // #3 HP
    HPSendCommand(ComNo, ":05*CLS "); // #3 HP
    HPSendCommand(ComNo, ":06SYST:REM"); // #4 HP
    HPSendCommand(ComNo, ":06*CLS "); // #4 HP
    HPSendCommand(ComNo, ":08SYST:REM"); // #5 HP
    HPSendCommand(ComNo, ":08*CLS "); // #5 HP
    HPSendCommand(ComNo, ":09SYST:REM"); // #6 HP
    HPSendCommand(ComNo, ":09*CLS "); // #6 HP
    WaitClock(18);
}

void CloseHP(int ComNo)
{
    HPSendCommand(ComNo, ":02*CLS"); // #1 HP
    HPSendCommand(ComNo, ":02SYST:LOC"); // #1 HP
    HPSendCommand(ComNo, ":03*CLS"); // #2 HP
    HPSendCommand(ComNo, ":03SYST:LOC"); // #2 HP
    HPSendCommand(ComNo, ":05*CLS"); // #3 HP
    HPSendCommand(ComNo, ":05SYST:LOC"); // #3 HP
    HPSendCommand(ComNo, ":06*CLS"); // #4 HP
    HPSendCommand(ComNo, ":06SYST:LOC"); // #4 HP
    HPSendCommand(ComNo, ":08*CLS"); // #5 HP
    HPSendCommand(ComNo, ":08SYST:LOC"); // #5 HP
    HPSendCommand(ComNo, ":09*CLS"); // #6 HP
    HPSendCommand(ComNo, ":09SYST:LOC"); // #6 HP
    CloseCOM(ComNo);
}
```

3. Command Sets

3.0.1 Command Set Table

Command	Response	Description	Reference
\$AAA[addr]	!AA	Read/Set the Module Address	Sec. 3.1
\$AABN[baud rate]	!AA[baud rate]	Read/Set Baud Rate of COM-1/2/3/4/5/6/7/8	Sec. 3.2
\$AADN[data-bit]	!AA[data-bit]	Read/Set the Data-Bit of COM-1/2/3/4/5/6/7/8	Sec. 3.3
\$AAPN[data-bit]	!AA[parity-bit]	Read/Set the Parity-Bit of COM-1/2/3/4/5/6/7/8	Sec. 3.4
\$AAON[data-bit]	!AA[stop-bit]	Read/Set the Stop-Bit of COM-1/2/3/4/5/6/7/8	Sec. 3.5
\$AA6(ID)	!AA	Set the ID-string of COM-1/3/4/5/6/7/8	Sec. 3.6
\$AA7	!AA(ID)	Read the ID-string of COM-1/3/4/5/6/7/8	Sec. 3.7
\$AAC[delimiter]	!AA[delimiter]	Read/Set the delimiter of COM-1/3/4/5/6/7/8	Sec. 3.8
\$AAD	!AA(delimiter)	Read the delimiter of COM-1/3/4/5/6/7/8	Sec. 3.9
(delimiter)AA(bypass)	!AA	Bypass data-string to COM-1/3/4/5/6/7/8	Sec. 3.10
\$AAK[checksum]	!AA(checksum)	Read/Set the checksum-status of COM2(RS485)	Sec. 3.11
\$AATN[CrLfMode]	!AA(CrLfMode)	Read/Set the end-char of COM-1/2/3/4	Sec. 3.12
\$AAW	!AAS	Read the CTS status of COM-1/3	Sec. 3.13
\$AAXV	!AA	Set the RTS state of COM-1/3	Sec. 3.14
\$AAYN	!AA	Read the onboard DI-1/2/3	Sec. 3.15
\$AAZNV	!AA	Set the onboard D/O-1/2/3	Sec. 3.16
#**	No Response	Synchronized Sampling	Sec. 3.17
\$AA4	!AASV	Read the synchronized data	Sec. 3.18
\$AA5	!AAS	Read the Reset- status	Sec. 3.19
\$AAF	!AA(number)	Read the firmware version number	Sec. 3.20
\$AAM	!AA(name)	Read the module name	Sec. 3.21
\$AA2	!AABDPK	Read the configuraton of COM2(RS485)	Sec. 3.22
~**	No Response	Host is OK	Sec. 3.23
~AA0	!AASS	Read the module status	Sec. 3.24
~AA1	!AA	Reset the module status	Sec. 3.25
~AA2	!AASTT	Read the host watchdog status & value	Sec. 3.26
~AA3ETT	!AA	Enable the host watchdog timer	Sec. 3.27
~AA4P/~AA4S	!AAV	Read power-on/safe value	Sec. 3.28
~AA5P/~AA5S	!AAV	Set power-on/safe value	Sec. 3.29
\$AAU	(data)	Read data from the RS-232 COM port buffer.	Sec. 3.30
\$AAL(data)	!AA	Write to expansion board DO 0/1/2/3	Sec. 3.31
\$AAR	!AA(data)	Read the expansion board DI-0/1/2/3	Sec. 3.32

3.0.2 Address mapping:

	7521	7522	7523	7522A	7524	7527
COM1(RS232)	AA	AA	AA	AA	AA	AA
COM2(RS485)	AA	AA	AA	AA	AA	AA
COM3(RS232)	N/A	AA+1	AA+1	AA+1	AA+1	AA+1
COM4(RS232)	N/A	N/A	AA+2	N/A	AA+2	AA+2
COM5(RS232)	N/A	N/A	N/A	N/A	AA+3	AA+3
COM6(RS232)	N/A	N/A	N/A	N/A	N/A	AA+4
COM7(RS232)	N/A	N/A	N/A	N/A	N/A	AA+5
COM8(RS232)	N/A	N/A	N/A	N/A	N/A	AA+6

3.2 \$AABN[baud rate]

7521/7522/7522A/7523/7524/7527

- **Description:** Read/Set the baud rate of COM-1/2/3/4./5/6/7/8
\$AABN[chk](CrLf): Read baud rate of COM-1/2/3/4 stored in EEPROM
\$AABN(baud rate)[chk](CrLf): Set baud rate of COM-1/2/3/4
- **Syntax:** \$AABN[baud rate][chk](CrLf)
\$ is a delimiter character
AA=2-character HEX module address, from 00 to FF
N=0 → Read/Set baud rate of RS485, N=1 → Read/Set baud rate of RS232
[baud rate]: 300/600/1200/2400/4800/9600/19200/38400/57600/115200
[chk]=2-character checksum, if checksum disabled → no [chk]
(CrLf)=End-Char
- **Response:** valid command → !AA[baud rate][chk](CrLf)
invalid command → ?AA[chk](CrLf)
no response : → syntax error or communication error or address error
! is a delimiter character indicating a valid command
? is a delimiter character indicating an invalid command
AA=2-character HEX module address
[chk]=2-character checksum, if checksum disabled → no [chk]
(CrLf)=End-Char
- **Example:** (Assume the AA of 7523 is 01)
command: \$01B0115200(CrLf)

Changes RS485(COM2) to 15200 BPS

response : !01(CrLf)
command: \$01B19600(CrLf)

Changes RS232(COM1) to 9600 BPS

response : !01(CrLf)
command: \$02B138400(CrLf)

Changes RS232(COM3) to 38400 BPS

response : !02(CrLf)
command: \$03B157600(CrLf)

Changes RS232(COM4) to 57600 BPS

response : !03(CrLf)

ADDRESS MAPPING:REFER TO PAGE 51

SHORT-CODE FOR BAUD RATE:

300=1, 600=2, 1200=3, 2400=4, 4800=5, 9600=6, 19200=7, 38400=8, 57600=9, 115200=A. THE SHORT-CODE OF BAUD RATE WILL BE SHOWN IN THE 7-SEGMENT LED3. REFER TO SEC. 1.2 QUICK START 1 FOR MORE INFORMATION.

3.3 \$AADN[data-bit]

7521/7522/7522A/7523/7524/7527

DESCRIPTION: READ/SET THE DATA-BIT OF COM-1/2/3/4/5/6/7/8

\$AADN[chk](CrLf): Read the data-bit of COM-1/2/3/4 stored in EEPROM

\$AADN(data-bit)[chk](CrLf): Set the data-bit of COM-1/2/3/4

- **Syntax:** \$AADN[data-bit][chk](CrLf)

\$ is a delimiter character

AA=2-character HEX module address, from 00 to FF

N=0 → Read/Set the data-bit of RS485, N=1 → Read/Set the data-bit of RS232

[data-bit]: 7 or 8

[chk]=2-character checksum, if checksum disabled → no [chk]

(CrLf)=End-Char

- **Response:** valid command → !AA[data-bit][chk](CrLf)
 invalid command → ?AA[chk](CrLf)
 no response : → syntax error or communication error or address error

! is a delimiter character indicating a valid command

? is a delimiter character indicating an invalid command

AA=2-character HEX module address

[chk]=2-character checksum, if checksum disabled → no [chk]

(CrLf)=End-Char

- **Example:** (Assume the AA of 7523 is 01)

command: \$01D08(CrLf)

Changes data-bit of RS485(COM2) to 8

response : !01(CrLf)

command: \$01D17(CrLf)

Changes data-bit of RS232(COM1) to 7

response : !01(CrLf)

command: \$02D17(CrLf)

Changes data-bit of RS232(COM3) to 7

response : !02(CrLf)

command: \$03D17(CrLf)

Changes data-bit of RS232(COM4) to 7

response : !03(CrLf)

ADDRESS MAPPING:REFER TO PAGE 51

VALID DATA-BIT:

	COM1	COM2	COM3	COM4	COM5	COM6	COM7	COM8
7521	7/8	7/8	N/A	N/A	N/A	N/A	N/A	N/A
7522	7/8	7/8	7/8	N/A	N/A	N/A	N/A	N/A
7522A	7/8	7/8	7/8	N/A	N/A	N/A	N/A	N/A
7523	7/8	7/8	7/8	7/8	N/A	N/A	N/A	N/A
7524	7/8	7/8	7/8	7/8	7/8	N/A	N/A	N/A
7527	7/8	7/8	7/8	7/8	7/8	7/8	7/8	7/8

3.4 \$AAPN[data-bit]

7521/7522/7522A/7523/7524/7527

DESCRIPTION: READ/SET THE PARITY-BIT OF COM-1/2/3/4/5/6/7/8

\$AAPN[chk](CrLf): Read the parity-bit of COM-1/2/3/4 stored in EEPROM

\$AAPN(parity-bit)[chk](CrLf): Set the parity-bit of COM-1/2/3/4

- **Syntax:** \$AAPN[parity-bit][chk](CrLf)

\$ is a delimiter character

AA=2-character HEX module address, from 00 to FF

N=0 → Read/Set the parity-bit of RS485, N=1 → Read/Set the parity-bit of RS232

[parity-bit]: 0=NONE, 1=EVEN, 2=ODD

[chk]=2-character checksum, if checksum disabled → no [chk]

(CrLf)=End-Char

- **Response:** valid command → !AA[data-bit][chk](CrLf)
 invalid command → ?AA[chk](CrLf)
 no response : → syntax error or communication error or address error

! is a delimiter character indicating a valid command

? is a delimiter character indicating an invalid command

AA=2-character HEX module address

[chk]=2-character checksum, if checksum disabled → no [chk]

(CrLf)=End-Char

- **Example:** (Assume the AA of 7523 is 01)

command: \$01P00(CrLf)

Changes parity-bit of RS485(COM2) to NONE

response : !01(CrLf)

command: \$01P10(CrLf)

Changes parity-bit of RS232(COM1) to NONE

response : !01(CrLf)

command: \$02P11(CrLf)

Changes parity-bit of RS232(COM3) to EVEN

response : !02(CrLf)

command: \$03P12(CrLf)

Changes parity-bit of RS232(COM4) to ODD

response : !03(CrLf)

ADDRESS MAPPING:REFER TO PAGE 51

VALID PARITY-BIT:

	7521	7522	7522A	7523	7524	7527
COM1(RS232)	N/E/O	N/E/O	N/E/O	N/E/O	N/E/O	N/E/O
COM2(RS485)	N/E/O	N/E/O	N/E/O	N/E/O	N/E/O	N/E/O
COM3(RS232)*	N/A	N/E/O	N/E/O	N/E/O	N/E/O	N/E/O
COM4(RS232)	N/A	N/A	N/A	N/E/O	N/E/O	N/E/O
COM5(RS232)	N/A	N/A	N/A	N/A	N/E/O	N/E/O
COM6(RS232)	N/A	N/A	N/A	N/A	N/A	N/E/O
COM7(RS232)	N/A	N/A	N/A	N/A	N/A	N/E/O
COM8(RS232)	N/A	N/A	N/A	N/A	N/A	N/E/O

*The Com3 of 7522A is RS-422/485

3.5 \$AAON[stop-bit]

7522/7523/7524/7527

DESCRIPTION: READ/SET THE STOP-BIT OF COM-3/4/5/6/7/8

\$AAON[chk](CrLf): Read the stop-bit of COM-3/4 stored in EEPROM

\$AAON(stop-bit)[chk](CrLf): Set the stop-bit of COM-3/4

- **Syntax:** \$AAPN[stop-bit][chk](CrLf)

\$ is a delimiter character

AA=2-character HEX module address, from 00 to FF

N=0 → Read/Set the parity-bit of RS485, N=1 → Read/Set the parity-bit of RS232

[stop-bit]: 1 for COM1/2 , 1/2 for COM3/4

[chk]=2-character checksum, if checksum disabled → no [chk]

(CrLf)=End-Char

- **Response:** valid command → !AA[data-bit][chk](CrLf)
 invalid command → ?AA[chk](CrLf)
 no response : → syntax error or communication error or address error

! is a delimiter character indicating a valid command

? is a delimiter character indicating an invalid command

AA=2-character HEX module address

[chk]=2-character checksum, if checksum disabled → no [chk]

(CrLf)=End-Char

- **Example:** (Assume the AA of 7523 is 01)

command: \$02O12(CrLf)

Changes the stop-bit of RS232(COM3) to 2

response : !02(CrLf)

command: \$03O12(CrLf)

Changes the stop-bit of RS232(COM4) to 2

response : !03(CrLf)

ADDRESS MAPPING: REFER TO PAGE 51

Valid stop-bit:

	7521	7522	7522A	7523	7524	7527
COM1(RS232)	1	1	1	1	1	1
COM2(RS485)	1	1	1	1	1	1
COM3(RS232)*	N/A	1 OR 2	1	1 OR 2	1 OR 2	1 OR 2
COM4(RS232)	N/A	N/A	N/A	1 OR 2	1 OR 2	1 OR 2
COM5(RS232)	N/A	N/A	N/A	N/A	1 OR 2	1 OR 2
COM6(RS232)	N/A	N/A	N/A	N/A	N/A	1 OR 2
COM7(RS232)	N/A	N/A	N/A	N/A	N/A	1 OR 2
COM8(RS232)	N/A	N/A	N/A	N/A	N/A	1 OR 2

*The com3 of 7522A is RS-422/485

- Note: The stop-bit of COM1 & COM2 is always 1.
- Note: The stop-bit of HP34401A must be 2. So, COM1 of 7521/7522/7523 cannot link to HP34401A.
- Note: COM3 & COM4 of 7522/7523 can link to HP34401A

3.6 \$AA6(ID)

7521/7522/7522A/7523/7524/7527

DESCRIPTION: SET THE ID-STRING OF COM-1/3/4/5/6/7/8, MAX.=50 CHARACTERS

- **Syntax:** \$AA6(ID)[chk](CrLf)
\$ is a delimiter character
AA=2-character HEX module address, from 00 to FF
(ID): ID-string, max. 50 characters.
[chk]=2-character checksum, if checksum disabled → no [chk]
(CrLf)=End-Char
- **Response:** valid command → !AA[chk](CrLf)
invalid command → ?AA[chk](CrLf)
no response : → syntax error or communication error or address error
! is a delimiter character indicating a valid command
? is a delimiter character indicating an invalid command
AA=2-character HEX module address
[chk]=2-character checksum, if checksum disabled → no [chk]
(CrLf)=End-Char
- **Example:** (Assume the AA of 7523 is 01)
command: \$016Temperature1(CrLf)
response : !01(CrLf)

ID of RS232(COM1) is Temperature1

command: \$026HP34401A-1(CrLf)
response : !02(CrLf)

ID of RS232(COM3) is HP34401A-1

command: \$036HP34401A-2(CrLf)
response : !03(CrLf)

ID of RS232(COM4) is HP34401A-2

ADDRESS MAPPING: REFER TO PAGE 51

3.7 \$AA7

7521/7522/7522A/7523/7524/7527

DESCRIPTION: READ THE ID=STRING OF COM-1/3/4/5/6/7/8

- **Syntax:** \$AA7[chk](CrLf)
\$ is a delimiter character
AA=2-character HEX module address, from 00 to FF
[chk]=2-character checksum, if checksum disabled → no [chk]
(CrLf)=End-Char
- **Response:** valid command → !AA(ID)[chk](CrLf)
invalid command → ?AA[chk](CrLf)
no response : syntax error or communication error or address error

(ID): ID-string, max. 50 characters.

! is a delimiter character indicating a valid command

? is a delimiter character indicating an invalid command

AA=2-character HEX module address

[chk]=2-character checksum, if checksum disabled → no [chk]

(CrLf)=End-Char

- **Example:** (Assume the AA of 7523 is 01)

command: \$017(CrLf)

response : !01Temperature1(CrLf)

ID of RS232(COM1) is Temperature1

command: \$027(CrLf)

response : !02HP34401A-1(CrLf)

ID of RS232(COM3) is HP34401A-1

command: \$037(CrLf)

response : !03HP34401A-2(CrLf)

ID of RS232(COM4) is HP34401A-2

ADDRESS MAPPING: REFER TO PAGE 51

3.8 \$AAC[delimiter]

7521/7522/7522A/7523/7524/7527

DESCRIPTION: READ/SET THE DELIMITER OF COM-1/3/4/5/6/7/8

\$AAC[chk](CrLf): Read the delimiter of COM-1/3/4 stored in EEPROM

\$AAC(delimiter)[chk](CrLf): Set the delimiter of COM-1/3/4

- **Syntax:** \$AAC[delimiter][chk](CrLf)

\$ is a delimiter character

AA=2-character HEX module address, from 00 to FF

[delimiter]: default delimiter is :

[chk]=2-character checksum, if checksum disabled → no [chk]

(CrLf)=End-Char

- **Response:** valid command → !AA[delimiter][chk](CrLf)
invalid command → ?AA[chk](CrLf)
no response : → syntax error or communication error or address error

! is a delimiter character indicating a valid command

? is a delimiter character indicating an invalid command

AA=2-character HEX module address

[chk]=2-character checksum, if checksum disabled → no [chk]

(CrLf)=End-Char

- **Example:** (Assume the AA of 7523 is 01)

command: \$01C(CrLf)

response : !01:(CrLf)

Reads the delimiter of RS232(COM2) → :

command: \$02C(CrLf)

response : !02:(CrLf)

Reads the delimiter of RS232(COM3) → :

command: \$03C*(CrLf)

response : !03(CrLf)

Changes the delimiter of RS232(COM4) → *

ADDRESS MAPPING: REFER TO PAGE 51

- Note1: The delimiter of COM1/3/4/5/6/7/8 can be different.
- Note 2: The default delimiter is → :
- Note 3: the delimiter cannot be \$, ~, #, @, %, CR & LF

3.9 \$AAD

7521/7522/7522A/7523/7524/7527

DESCRIPTION: READ THE DELIMITER OF COM-1/3/4/5/6/7/8

- **Syntax:** \$AAD[chk](CrLf)

\$ is a delimiter character

AA=2-character HEX module address, from 00 to FF

[chk]=2-character checksum, if checksum disabled → no [chk]

(CrLf)=End-Char

- **Response:** valid command → !AA(delimiter)[chk](CrLf)
invalid command → ?AA[chk](CrLf)
no response : → syntax error or communication error or address error

(delimiter): default delimiter is :

! is a delimiter character indicating a valid command

? is a delimiter character indicating an invalid command

AA=2-character HEX module address

[chk]=2-character checksum, if checksum disabled → no [chk]

(CrLf)=End-Char

- **Example:** (Assume the AA of 7523 is 01)

command: \$01D(CrLf)

Reads the delimiter of RS232(COM1) → :

response : !01:(CrLf)

command: \$02D(CrLf)

Reads the delimiter of RS232(COM3) → :

response : !02:(CrLf)

command: \$03D(CrLf)

Reads the delimiter of RS232(COM4) → *

response : !03*(CrLf)

ADDRESS MAPPING: REFER TO PAGE 51

- Note1: The delimiter of COM1/3/4/5/6/7/8 can be different.
- Note 2: The default delimiter is → :

3.10 (delimiter)AA(bypass)

7521/7522/7522A/7522
/7524/7527

DESCRIPTION: BYPASS DATA-STRING TO COM-1/3/4/5/6/7/8

- **Syntax:** (delimiter)AA(bypass)[chk](CrLf)
AA=2-character HEX module address, from 00 to FF
(bypass): data-string send to COM-1/3/4
[chk]=2-character checksum, if checksum disabled → no [chk]
(CrLf)=End-Char
- **Response:** valid command → !AA[chk](CrLf)
invalid command → ?AA[chk](CrLf)
no response : → syntax error or communication error or address error

! is a delimiter character indicating a valid command

? is a delimiter character indicating an invalid command

AA=2-character HEX module address

[chk]=2-character checksum, if checksum disabled → no [chk]

(CrLf)=End-Char

- **Example:** (Assume the AA of 7523 is 01, the delimiters for **COM1/3/4** are :;/*)

command: :01abcde(CrLf)

response : !01(CrLf)

Sends **abcde** to COM1

command: ;02123456789(CrLf)

response : !02(CrLf)

Sends **123456789** to COM3

command: *03test(CrLf)

response : !03(CrLf)

Sends **test** to COM4

ADDRESS MAPPING: REFER TO PAGE 51

3.11 \$AAK[checksum]

7521/7522/7522A/7523/7524/7527

DESCRIPTION: READ/SET THE CHECKSUM-STATUS

\$AAK[chk](CrLf): Read the checksum-status stored in EEPROM

\$AAK(checksum)[chk](CrLf): Set the checksum-status

- **Syntax:** \$AAK[checksum][chk](CrLf)

\$ is a delimiter character

AA=2-character HEX module address, from 00 to FF

[checksum]: 0= checksum disable, 1= checksum enable

[chk]=2-character checksum, if checksum disabled → no [chk]

(CrLf)=End-Char

- **Response:** valid command → !AA[checksum][chk](CrLf)
invalid command → ?AA[chk](CrLf)
no response : → syntax error or communication error or address error

! is a delimiter character indicating a valid command

? is a delimiter character indicating an invalid command

AA=2-character HEX module address

[chk]=2-character checksum, if checksum disabled → no [chk]

(CrLf)=End-Char

- **Example:** (Assume the AA of 7523 is 01, the other AA of 7523 is 04)

command: \$01K0(CrLf)

Disables checksum

response : !01(CrLf)

command: \$04K(CrLf)

The checksum is enabled

response : !041(CrLf)

- **Note:** the checksum enable/disable is valid to COM2 only.

3.12 \$AATN[CrLfMode]

7521/7522/7522A/7523/7524/7527

DESCRIPTION: READ/SET THE END-CHAR OF COMMAND STRING

\$AATN[chk](CrLf): Read the end-char of command string stored in EEPROM

\$AATN(CrLfMode)[chk](CrLf): Set the end-char of command string

- **Syntax:** \$AATN[CrLfMode][chk](CrLf)

\$ is a delimiter character

AA=2-character HEX module address, from 00 to FF

N=0 → Read/Set the parity-bit of RS485, N=1 → Read/Set the parity-bit of RS232

(CrLfMode): 0 → (CrLf)=0x0D
 1 → (CrLf)=0x0D+0x0A
 2 → (CrLf)=0x0A
 3 → (CrLf)=0x0A+0x0D
 4. → No end-char

[chk]=2-character checksum, if checksum disabled → no [chk]

(CrLf)=End-Char

- **Response:** valid command → !AA[data-bit][chk](CrLf)
 invalid command → ?AA[chk](CrLf)
 no response : → syntax error or communication error or address error

! is a delimiter character indicating a valid command

? is a delimiter character indicating an invalid command

AA=2-character HEX module address

[chk]=2-character checksum, if checksum disabled → no [chk]

(CrLf)=End-Char

- **Example:** (Assume the AA of 7523 is 01)

command: \$01T0(CrLf)

The end-char of COM2 is no end character

response : !014(CrLf)

command: \$01T1(CrLf)

The end-char of COM1 is 0x0D+0x0A

response : !011(CrLf)

command: \$02T1(CrLf)

The end-char of COM3 is 0x0A

response : !022(CrLf)

command: \$03T1(CrLf)

The end-char of COM4 is 0x0A+0x0D

response : !033(CrLf)

ADDRESS MAPPING: REFER TO PAGE 51

- Note: the default CrLfMode = 4 → the default (CrLf)=NONE for all port.

3.13 \$AAW

7521/7522/7522A/7523/7524/7527

DESCRIPTION: READ THE CTS-STATUS OF COM-1/3

SYNTAX: \$AAW[CHK](CRLF)

\$ is a delimiter character

AA=2-character HEX module address, from 00 to FF

[chk]=2-character checksum, if checksum disabled → no [chk]

(CrLf)=End-Char

- **Response:** valid command → !AAS[chk](CrLf)
invalid command → ?AA[chk](CrLf)
no response : → syntax error or communication error or address error

S: 0 → CTS is inactive now, 1 → CTS is active_HIGH now

! is a delimiter character indicating a valid command

? is a delimiter character indicating an invalid command

AA=2-character HEX module address

[chk]=2-character checksum, if checksum disabled → no [chk]

(CrLf)=End-Char

- **Example:** (Assume the AA of 7523 is 01)

command: \$01W(CrLf)

The CTS of COM1 is inactive now.

response : !010(CrLf)

command: \$02W(CrLf)

The CTS of COM3 is active-HIGH now.

response : !021(CrLf)

ADDRESS MAPPING FOR CTS-STATUS:

	COM1(RS232)	COM3(RS232)
7521	AA	N/A
7522	AA	AA+1
7522A	AA	N/A
7523	AA	AA+1
7524	AA	AA+1
7527	AA	AA+1

- Note1: The CTS-status is valid for COM1 & COM3

3.14 \$AAXV

7521/7522/7522A/7523/7524/7527

DESCRIPTION: SET THE RTS-STATE OF COM-1/3

- **Syntax:** \$AAXV[chk](CrLf)

\$ is a delimiter character

AA=2-character HEX module address, from 00 to FF

V: 0 → set RTS inactive, 1 → set RTS to active_HIGH state

[chk]=2-character checksum, if checksum disabled → no [chk]

(CrLf)=End-Char

- **Response:** valid command → !AA[chk](CrLf)
invalid command → ?AA[chk](CrLf)
no response : → syntax error or communication error or address error

! is a delimiter character indicating a valid command

? is a delimiter character indicating an invalid command

AA=2-character HEX module address

[chk]=2-character checksum, if checksum disabled → no [chk]

(CrLf)=End-Char

- **Example:** (Assume the AA of 7523 is 01)

command: \$01X0(CrLf)

Sets the RTS of COM1 to inactive state

response : !01(CrLf)

command: \$02X1(CrLf)

Sets the RTS of COM3 to active-HIGH state

response : !02(CrLf)

ADDRESS MAPPING FOR RTS-STATE:

	COM1(RS232)	COM3(RS232)
7521	AA	N/A
7522	AA	AA+1
7522A	AA	N/A
7523	AA	AA+1
7524	AA	AA+1
7527	AA	AA+1

- Note1: The RTS-state is valid for COM1 & COM3

3.15 \$AAYN

7521/7522/7522A/7523/7524/7527

DESCRIPTION: READ THE ONBOARD DI-1/2/3

- Syntax:** \$AAYN[chk](CrLf)
 \$ is a delimiter character
 AA=2-character HEX module address, from 00 to FF
 N: 1 → read DI1, 2 → read DI2, 3 → read DI3
 [chk]=2-character checksum, if checksum disabled → no [chk]
 (CrLf)=End-Char
- Response:** valid command → !AAS[chk](CrLf)
 invalid command → ?AA[chk](CrLf)
 no response : → syntax error or communication error or address error

! is a delimiter character indicating a valid command
 ? is a delimiter character indicating an invalid command
 AA=2-character HEX module address
 S=0 → DI=Low, 1 → DI=High (DI floating will get High)
 [chk]=2-character checksum, if checksum disabled → no [chk]
 (CrLf)=End-Char

- Example:** (Assume the AA of 7521 is 01)

command:	\$01Y1(CrLf)	
response :	!010(CrLf)	DI1=Low
command:	\$01Y2(CrLf)	
response :	!011(CrLf)	DI2=High
command:	\$01Y3(CrLf)	
response :	!010(CrLf)	DI3=Low

DI MAPPING TABLE:

	DI1	DI2	DI3
7521	YES	YES	YES
7522	YES	YES	YES
7522A	YES	NO	NO
7523	YES	YES	NO
7524	YES	NO	NO
7527	YES	NO	NO

3.16 \$AAZNV

7521/7522/7522A/7524/7527

DESCRIPTION: WRITE TO ONBOARD DO-1/2/3

● **Syntax:** \$AAZNV[chk](CrLf)

\$ is a delimiter character

AA=2-character HEX module address, from 00 to FF

N: 1 → write DO1, 2 → write DO2, 3 → write DO3

V: 0 → set D/O off, 1 → set D/O on

[chk]=2-character checksum, if checksum disabled → no [chk]

(CrLf)=End-Char

- **Response:** valid command → !AA[chk](CrLf)
 invalid command → ?AA[chk](CrLf)
 no response : → syntax error or communication error or address error

! is a delimiter character indicating a valid command

? is a delimiter character indicating an invalid command

AA=2-character HEX module address

[chk]=2-character checksum, if checksum disabled → no [chk]

(CrLf)=End-Char

● **Example:** (Assume the AA of 7521 is 01)

command: \$01Z10(CrLf)

Set DO1=OFF

response : !01(CrLf)

command: \$01Z21(CrLf)

Set DO2=ON

response : !01(CrLf)

command: \$01Z30(CrLf)

Set DO3=OFF

response : !01(CrLf)

DO MAPPING TABLE:

	DO1	DO2	DO3
7521	YES	YES	YES
7522	YES	NO	NO
7522A	YES	NO	NO
7523	NO	NO	NO
7524	YES	NO	NO
7527	YES	NO	NO

NOTE: IF THE HOST FAILS, THE ~AAZNV COMMAND WILL BE IGNORED. AND THE RESPONSE STRING WILL BE !

(In normal situation, the response string will be !AA)

3.17 #**

- **Description:** Order all input modules, digital and analog, sample all their input data immediately and store this data in the internal register of the module. Later the host computer can read this data one by one by using the command **\$AA4, read synchronized data**.

- **Syntax:** #**[chk](CrLf)

is a delimiter character

* is a command character

[chk]=2-character checksum, if checksum disabled → no [chk]

(CrLf)=End-Char

- **Response:** no response

- **Example:**

command: #**(CrLf)

response: no response

command: \$014(CrLf)

response: !0117(CrLf)

command: \$024(CrLf)

response: !0213(CrLf)

command: \$034(CrLf)

response: !0311(CrLf)

Orders all modules to perform synchronized sampling

DI1=DI2=DI3=1

DI1=DI2=1, DI3=0

DI1=1, DI2=DI3=0

NOTE : What's "synchronize sampling" ?

The host computer can send only one command string at a time. If there are two modules, the host computer must send and receive the module-1 commands then the module-2 commands. **So there is a time delay between these two commands.** The "synchronize sampling" command is designed for all input modules. When receiving #**[CrLf], synchronized sampling command, **all input modules in the RS-485 network will perform the input function at the same time and store these values into the module's memory.** Then the host computer can send out the "\$AA4, read synchronize data" command to read this data separately.

3.18 \$AA4

7521/7522/7522A/7523/7524/7527

- **Description** : Reads the synchronized data.
- **Syntax** : \$AA4[chk](CrLf)
\$ is a delimiter character
AA=2-character HEX module address, from 00 to FF
[chk]=2-character checksum, if checksum disabled → no [chk]
(CrLf)=End-Char
- **Response** : valid command → !AASV[chk](CrLf)
invalid command → ?AA[chk](CrLf)
no response : syntax error or communication error or address error
! is a delimiter character indicating a valid command
? is a delimiter character indicating an invalid command
AA=2-character HEX module address
S=1=first reading
=0=not first reading
V: D0=DI1, D1=DI2, D2=DI3
[chk]=2-character checksum, if checksum disabled → no [chk]
(CrLf)=End-Char
- **Example** :
command: #**(CrLf)
response: no response
command: \$014(CrLf)

DI1=DI2=DI3=1

response: !0117(CrLf)
command: \$024(CrLf)

DI1=DI2=1, DI3=0

response: !0213(CrLf)
command: \$034(CrLf)

DI1=1, DI2=DI3=0

response: !0311(CrLf)

NOTE : What's "synchronize sampling" ?

The host computer can send only one command string at a time. If there are two modules, the host computer must send and receive the module-1 commands then the module-2 commands. **So there is a time delay between these two commands.** The "synchronize sampling" command is designed for all input modules. When receiving #**[CrLf], synchronized sampling command, **all input modules in the RS-485 network will perform the input function at the same time and store these values into the module's memory.** Then the host computer can send out the "\$AA4, read synchronize data" command to read this data separately.

3.19 \$AA5

7521/7522/7522A/7523/7524/7527

- **Description:** Resets status read back. This is the only command to detect the module hardware watchdog failure. If the module is down, the module hardware watchdog circuit will reset this module. This reset will cause the output state of the module to go to their start-value. The start-value may be different from those output-values before module reset. Therefore the user needs to send an output command again to the module for maintaining the same output state before and after module watchdog reset.
- **Syntax:** \$AA5[chk](CrLf)
\$ is a delimiter character
AA=2-character HEX module address, from 00 to FF
[chk]=2-character checksum, if checksum disabled → no [chk]
(CrLf)=End-Char
- **Response :** valid command → !AAS[chk](CrLf)
invalid command → ?AA[chk](CrLf)
no response : syntax error or communication error or address error
! is a delimiter character indicating a valid command
? is a delimiter character indicating an invalid command
S = 0, it has not been reset since the last reset status read
1, it has been reset since the last reset status read
[chk]=2-character checksum, if checksum disabled → no [chk]
(CrLf)=End-Char

- **Note:** When first powering-on, the user should read the module **once** and will find that S=1. Then the user should read the module **continually** and find that S=0. **If S is changed to 1, this module has been reset by module hardware watchdog circuit at least once. And all output is going to its start-value now.** Therefore the user needs to send an output command again to control all output values to desired states.

- **Example:**

command: \$015(CrLf)

It is first time power-on reset

response : !011(CrLf)

command: \$015(CrLf)

It is normal

response : !010(CrLf)

command: \$015(CrLf)

It is normal

response : !010(CrLf)

command: \$015(CrLf)

This module has been **reset** by module hardware watchdog. Therefore all output is going to its **start-values** now.

response : !011(CrLf)

3.22 \$AA2

7521/7522/7522A/7523/7524/7527

- **Description** : Reads the configuration code of COM2(RS485) stored in EEPROM
- **Syntax** : \$AA2[chk](cr)
\$ is a delimiter character
AA=2-character HEX module address, from 00 to FF
[chk]=2-character checksum, if checksum disabled → no [chk]
(cr)=0x0D
- **Response** : valid command → !AA40BDPK[chk](cr),
invalid command → ?AA[chk](cr)
no response : syntax error or communication error or address error
! is a delimiter character indicating a valid command
? is a delimiter character indicating an invalid command
AA=2-character HEX module address
B=short-code for baud rate, refer to Sec. 3.2
D=data-bit, refer to Sec. 3.3
P=party-bit, refer to Sec. 3.4
K=checksum status, refer to Sec. 3.5
[chk]=2-character checksum, if checksum disabled → no [chk]
(cr)=0x0D
- **Example**: (assume DI1/INIT*=GND)

command: \$002(cr)
response : !01406800(cr)

address 01 is 7521 series module, 9600 BPS,
N81, checksum disable
checksum disable

command: \$002(cr)
response : !0240A801(cr)

address 02 is 7521 series module, 115200
BPS, N81, checksum enable

3.23

~**

7521/7522/7522A/7523/7524/7527

- **Description** : Host computer sends this command to tell all modules “Host is OK”.
- **Syntax** : ~**[chk](CrLf)
~ is a delimiter character
[chk]=2-character checksum, if checksum disabled → no [chk]
(CrLf)=End-Char
- **Response** : no response
- **Example**:
command: ~**(CrLf)
response : No Response

3.24 ~AA0

7521/7522/7522A/7523/7524/7527

- **Description** : Reads the module status. The module status will be latched until ~AA1 command is sent. **If the module status=0x04, all output commands will be ignored.**
- **Syntax** : ~AA0[chk](CrLf)
~ is a delimiter character
AA=2-character HEX module address, from 00 to FF
[chk]=2-character checksum, if checksum disabled → no [chk]
(CrLf)=End-Char
- **Response** : valid command → !AASS[chk](CrLf)
invalid command → ?AA[chk](CrLf)
no response : syntax error or communication error or address error
! is a delimiter character indicating a valid command
? is a delimiter character indicating an invalid command
AA=2-character HEX module address
SS=2-character HEX status value as following:
Bit_0 = reserved
Bit_1 = reserved
Bit_2 = 0 → OK
1 → host watchdog failure
[chk]=2-character checksum, if checksum disabled → no [chk]
(CrLf)=End-Char
- **Example**:

command: ~010(CrLf)	Status of module 01 is OK
response : !0100(CrLf)	
command: ~020(CrLf)	Status of module 02 is “host watchdog failure” → HOST is down now
response : !0204(CrLf)	

3.25 ~AA1

7521/7522/7522A/7523/7524/7527

- **Description** : Resets module status. The module status will be latched until ~AA1 command is sent. **If the module status=0x04, all output commands will be ignored.** Therefore the user should read the module status first to make sure that the module status is 0. If the module status is not 0, only the ~AA1 command can clear the module status.
- **Syntax** : ~AA1[chk](CrLf)
~ is a delimiter character
AA=2-character HEX module address, from 00 to FF
[chk]=2-character checksum, if checksum disabled → no [chk]
(CrLf)=End-Char
- **Response** : valid command → !AA[chk](CrLf)
invalid command → ?AA[chk](CrLf)
no response : syntax error or communication error or address error
! is a delimiter character indicating a valid command
? is a delimiter character indicating an invalid command
AA=2-character HEX module address
[chk]=2-character checksum, if checksum disabled → no [chk]
(CrLf)=End-Char
- **Example:**

command: ~010(CrLf)	module status=0x04 → host is down
response : !0104(CrLf)	
command: \$01211(CrLf)	Output command is ignored
response : !(CrLf)	
command: ~011(CrLf)	clears module status
response : !01(CrLf)	
command: ~010(CrLf)	module status=0x00
response : !0100(CrLf)	
command: \$01211(CrLf)	
response : >(CrLf)	Output command is OK

7521 Series Module Status Comparison:

- (1) module hardware watchdog reset
 - all D/O goes to their start-values
 - **module status no change**
 - accept host D/O command to change D/O state
- (2) host software watchdog failure
 - all D/O goes to their save-value
 - **module status=04 → host watchdog failure**
 - **ignores all host D/O command until module status is cleared to 0 by ~AA1 command**

3.26 ~AA2

7521/7522/7522A/7523/7524/7527

- **Description** : Reads the status of host watchdog and the host watchdog timer value. The host watchdog timer is designed for software host watchdog. When the software host watchdog is enabled, the host must send ~**, HOST is OK command, to all modules before the timer is up. When the ~** command is received, the host watchdog timer is reset and restarted. Use ~AA3ETT to enable/disable/setting the host watchdog timer.
- **Syntax** : ~AA2[chk](CrLf)
~ is a delimiter character
AA=2-character HEX module address, from 00 to FF
[chk]=2-character checksum, if checksum disabled → no [chk]
(CrLf)=End-Char
- **Response** : valid command → !AASTT[chk](CrLf)
invalid command → ?AA[chk](CrLf)
no response : syntax error or communication error or address error
! is a delimiter character indicating a valid command
? is a delimiter character indicating an invalid command
AA=2-character HEX module address
S=0: host watchdog is disable, S=1:host watchdog is enable
TT=2-character HEX value, from 00 to FF, unit=0.1 second
[chk]=2-character checksum, if checksum disabled → no [chk]
(CrLf)=End-Char
- **Example**:

Host watchdog timer of module 01 is disabled
--

host watchdog timer of module 02 is enabled and =0.1*10 =1 second.
--

 - command: ~012(CrLf)
 - response : !01000(CrLf)
 - command: ~022(CrLf)
 - response : !0210A(CrLf)

7521 Series Module Status Comparison:

- (1) module hardware watchdog reset
 - all D/O goes to their start-values
 - **module status no change**
 - accept host D/O command to change D/O state
- (2) host software watchdog failure
 - all D/O goes to their save-values
 - **module status=04 → host watchdog failure**
 - **ignores all host D/O command until module status is cleared to 0 by ~AA1 command**

3.27 ~AA3ETT

7521/7522/7522A/7523/7524/7527

- **Description** : Enables/disables the host watchdog timer value. The host watchdog timer is designed for software host watchdog. When the software host watchdog is enabled, the host must send ~**, HOST is OK command, to all modules before the timer is up. When the ~** command is received, the host watchdog timer is reset and restarted. Use ~AA2 to read the host watchdog status & value.

- **Syntax** : ~AA3ETT[chk](CrLf)

~ is a delimiter character

AA=2-character HEX module address, from 00 to FF

E=0 is disable and 1 is enable

TT=2-character HEX value, from 00 to FF, unit=0.1 second

[chk]=2-character checksum, if checksum disabled → no [chk]

(CrLf)=End-Char

- **Response** : valid command → !AA[chk](CrLf)
invalid command → ?AA[chk](CrLf)
no response : syntax error or communication error or address error

! is a delimiter character indicating a valid command

? is a delimiter character indicating an invalid command

AA=2-character HEX module address

[chk]=2-character checksum, if checksum disabled → no [chk]

(CrLf)=End-Char

- **Example:**

command: ~013000(CrLf)

response : !01(CrLf)

disables host watchdog timer of module 01

command: ~02310A(CrLf)

response : !02(CrLf)

host watchdog timer of module 02 is enabled and equal to $0.1 \times 10 = 1$ second.

3.28 ~AA4P & ~AA4S

7521/7522/7522A/7524/7527

- **Description** : Reads power-on/safe value.
 - (1) When the module is **first powered-on**, all output channels will go to their **power-on value**.
 - (2) When the module is **down**, the hardware module watchdog will reset the module and all output channels will **also go to their power-on value**. **These power-on values may be different from old values before the module was reset**. Therefore the user must send out a new output command to change all output to their desired states.
 - (3) When the host watchdog is enabled and the **host is down**, all output will go to their **safe values** and module status will change to 0x04. If the module status is 0x04, all output commands will be ignored before the module status is cleared by ~AA1 command. Therefore the user must send ~AA1 command first, then send out a new output command to change all output to their desired states.
- **Syntax** : ~AA4P[chk](CrLf) → read power-on value
~AA4S[chk](CrLf) → read safe value
~ is a delimiter character
AA=2-character HEX module address, from 00 to FF
[chk]=2-character checksum, if checksum disabled → no [chk]
(CrLf)=End-Char
- **Response** : valid command → !AAV[chk](CrLf) for I-7042
invalid command → ?AA[chk](CrLf)
no response : syntax error or communication error or address error
! is a delimiter character indicating a valid command
? is a delimiter character indicating an invalid command
AA=2-character HEX module address
V: D0=DO0, D1=DO1, D2=DO3
[chk]=2-character checksum, if checksum disabled → no [chk]
(CrLf)=End-Char
- **Example**:

Power-on value is all DO-1/2/3 ON

command: ~014P(CrLf)
response : !017(CrLf)

Safe value is all DO-1/2/3 OFF

command: ~024S(CrLf)
response : !020(CrLf)

3.29 ~AA5P & ~AA5S

7521/7522/7522A/7524/7527

- **Description** : Sets current state of digital output as power-on/safe value.
 - (1) When the module is **first powered-on**, all output channels will go to their **power-on value**.
 - (2) When the module is **down**, the hardware module watchdog will reset the module and all output channels will **also go to their power-on value**. **These power-on values may be different from old values before the module was reset**. Therefore the user must send out a new output command to change all output to their desired states.
 - (3) When the host watchdog is enabled and the **host is down**, all output will go to their **safe values** and module status will change to 0x04. If the module status is 0x04, all output command will be ignored before the module status is clear by ~AA1 command. Therefore the user must send ~AA1 command first, then send out a new output command to change all output to their desired states.

- **Syntax** : ~AA5P[chk](CrLf) → set power-on value
~AA5S[chk](CrLf) → set safe value

~ is a delimiter character

AA=2-character HEX module address, from 00 to FF

[chk]=2-character checksum, if checksum disabled → no [chk]

(CrLf)=End-Char

- **Response** : valid command → !AAV[chk](CrLf)
invalid command → ?AA[chk](CrLf)
no response : syntax error or communication error or address error

! is a delimiter character indicating a valid command

? is a delimiter character indicating an invalid command

AA=2-character HEX module address

V: D0=DO0, D1=DO1, D2=DO3

[chk]=2-character checksum, if checksum disabled → no [chk]

(CrLf)=End-Char

- **Example:**

command: ~015P(CrLf)

response : !017(CrLf)

Power-on value is all DO-1/2/3 ON

command: ~025S(CrLf)

response : !020(CrLf)

Power-on value is all DO-1/2/3 OFF

3.30 \$AAU

- **Description:** Read data from the COM port buffer.
Any 232 device should obey the rules of request-reply constitution. In other word, 232 devices are passive. If they have not received any commands, they will not send any message out. However, since the active device frequently appear, our controller is designed with a buffer to receive these message in this situation.

Buffer operation rules:

Rule 1: buffer is enabled after power-on.

Rule 2: (delimiter) AA command (ref. Sec.3.10) disables buffer operation of that port

Rule 3: after disabling buffer, the first incoming message will transfer to COM2. Then controller waits for 10 seconds. If no message has arrived, the buffer is enabled again.

- **Syntax:** \$AAU[chk](CrLf)→read first data in buffer

\$ is a delimiter character

AA=2-character HEX module address, from 00 to FF

[chk]=2-character checksum, if checksum disable → no [chk]

(CrLf)=End-Char

Response : valid command → (data)[chk](CrLf)

invalid command → ?AA[chk](CrLf)

no response : buffer is empty or

syntax error or

communication error or

address error

! is a delimiter character indicating a valid command

? is a delimiter character indicating an invalid command

AA=2-character HEX module address

[chk]=2-character checksum, if checksum disabled → no [chk]

(CrLf)=End-Char

- **Example:**

Command: \$01U(CrLf)

Retrieves "data1" from buffer

Response: data1(CrLf)

Command: \$01U(CrLf)

Retrieves another data: "data2" from buffer

Response: data2

Command: \$02U(CrLf)

No data is in buffer.

Response:

Warning:

(1)Change CrLf mode will corrupt the integrity of unread data in the buffer

(2)Repeat this command several times to ensure the buffer is empty.

3.31 \$AAL(data)

Description: Write to expansion board DO 0/1/2/3

Syntax: \$AALbbbb[chk](CrLf), \$AALcb[chk](CrLf), \$AALh[chk](CrLf)

\$ is a delimiter character

AA=2-character HEX module address, from 00 to FF

b: 1 → set to On, 0 → set to Off

c: 0 → DO0, 1 → DO1, 2 → DO2, 3 → DO3

h: 4-bit hex value of DO. DO0 is at LSB. Valid value is 0~9, a~f, A~F

[chk]=2-character checksum, if checksum disabled → no [chk]

(CrLf)=End-Char

Response: valid command → !AA[chk](CrLf)

invalid command → ?AA[chk](CrLf)

no response : → syntax error or communication error or address

error

! is a delimiter character indicating a valid command

? is a delimiter character indicating an invalid command

AA=2-character HEX module address

[chk]=2-character checksum, if checksum disabled → no [chk]

(CrLf)=End-Char

Example: (Assume the AA of 7521 is 01)

command: \$01L1000(CrLf)

Set DO3=ON, DO2,DO1,DO0=0

response : !01 08(CrLf)

command: \$01L21(CrLf)

Set DO2=ON, other DOn are unchanged.

response : !01 0H(CrLf)

command: \$01L30(CrLf)

Set DO3=OFF, other DOn are unchanged.

response : !01 0H(CrLf)

command: \$01LE(CrLf)

Set DO0=OFF, DO1,DO2,DO3=ON

response : !01 0E(CrLf)

Note: If the host fails, the ~AAL command will be ignored. And the response string will be ?AA (In normal situation, the response string will be !AA 0H)

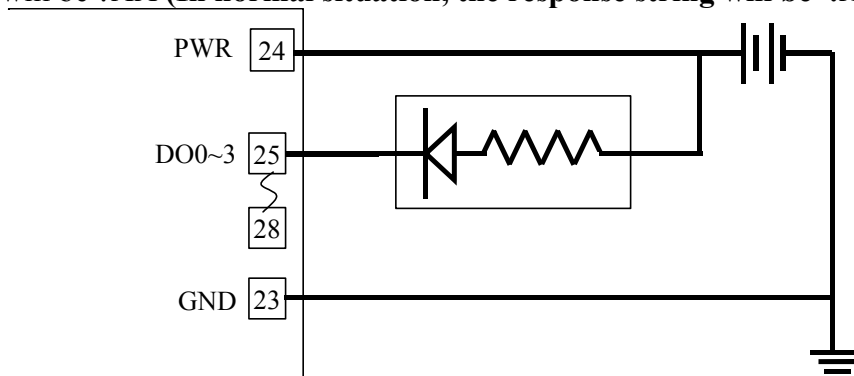

3.32 \$AAR

Description: Read the expansion board DI-0/1/2/3

Syntax: \$AAR[chk](CrLf)

\$ is a delimiter character

AA=2-character HEX module address, from 00 to FF

[chk]=2-character checksum, if checksum disabled → no [chk]

(CrLf)=End-Char

Response: valid command → !AAN[N][chk](CrLf)

invalid command → ?AA[chk](CrLf)

no response : → syntax error or communication error or address

error

! is a delimiter character indicating a valid command

? is a delimiter character indicating an invalid command

AA=2-character HEX module address

S=0 → DI=Low, 1 → DI=High (DI floating will get High)

[chk]=2-character checksum, if checksum disabled → no [chk]

(CrLf)=End-Char

Example: (Assume the AA of 7521 is 01)

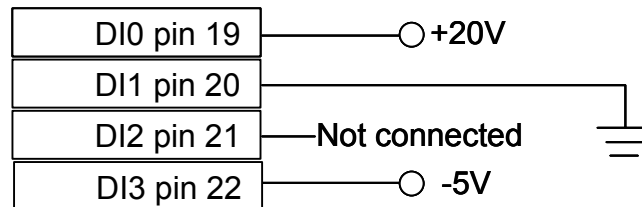

command: \$01R(CrLf)

response : !015(CrLf)

DI3,DI1=low(0), DI2,DI0=high(1)

4. Operational Principles & Application Notes

4.1 DI1/INIT* Pin Operation Principles

The 7521 series modules contains an EEPROM to store configuration information. Therefore it is difficult for the user to find out the status of the 7521 series modules. The steps to get the configuration data stored in EEPROM are given as follows:

Stage 1: refer to Step1 ~ Step4 of Sec. 1.6

Stage 2: keyin 7521 & Enter-key to execute 7521.exe (DI1/INIT* is connected to GND now)

Stage 3: send command to 7521 for configuration reading

Then the 7521 series modules will **go to the factory default setting** without changing the EEPROM data. The factory default setting is given as following:

address = **00**
baud rate = **9600**
checksum = **DISABLE**
data format = **1 start + 8 data bits + 1 stop bit (N 8 1)**

If disconnecting the DI1/INIT*_pin and GND_pin, the I_7000 module will auto configure based on the EEPROM data. For the user, it is easy to find the EEPROM configuration data in the default setting. The steps are shown as following:

Step 1 : power off and connect DI1/INIT*_pin to GND_pin

Step 2 : power on & refer to step1 ~ step4 of Sec. 1.6

Step 3: keyin 7521 & Enter-key to execute 7521.exe

Step 4 : send command string **\$00M[0x0D]**

Step 5 : record the module name

Step 6 : send command string **\$00A[0x0D]**

Step 7 : record the module address

Step 8 : send command string **\$00B[0x0D]**

Step 9 : record the baud rate

Step 10 : send command string **\$00D[0x0D]**

Step 11: record the data-bit

Step 12: send command string **\$00P[0x0D]**

Step 13: record the parity-bit

Step 14: send command string **\$00K0[0x0D]**

Step 15: record the checksum status

Step 16: power off and disconnect INIT*_pin and GND_pin

Step 17: power on, the 7521 series will work in the same status as your record

Note: step 6 to step 15 can be replaced by **\$002[0x0D]** command

4.2 D/O Operating Principles

- (1) The D/O of the 7521 series will **go to their start-values after first powering on.**
- (2) The D/O output will change to desired state if the “\$AAZNV” command is received. Then, all the D/O will remain in the same states until next “\$AAZNV” command.
- (3) If the 7521 series is **reset by the hardware watchdog, all D/O will go to their power-on values immediately.** These power-on values may be different from the original states before reset. So the D/O states stored in Host-PC may be different from real D/O states latched in the 7521 series. The Host-PC must send the “\$AAZNV” command to set these D/O to expected states.
- (4) The Host-PC can use “\$AA5” command to detect the hardware watchdog reset. Refer to Sec. 4.6 for more information. If the 7521 series is reset by hardware watchdog, the Host-PC should send out “\$AAZNV” command to set all D/O to their expected states.
- (5) If the host watchdog fails, all the D/O will **go to their safe-values immediately and the module status will be set to 04.** If the host computer sends out “\$AAZNV” to these modules now, the modules will **ignore this command and return “!” as warning information.** The host can **use the “~AA1” command to clear the module status to 00,** then the 7521 series will accept the “\$AAZNV” command again.

4.3 D/I Operating Principles

The I-7000 series D/I commands are given as follows:

- (1) **#**:** synchronized sampling, all modules will sample DI at the same time
- (2) **\$AA4:** reads synchronized sampling data.
- (3) **\$AAYN:** reads current state of D/I

The host computer can send only one command string at a time. If there are two modules, the host computer must send and receive the module-1 commands then the module-2 commands. **So there is a time delay between these two commands.** The “synchronize sampling” command is designed for all input modules. When receiving “#**[0x0D]”, synchronized sampling command, **all the input modules in the RS-485 network will perform the input function at the same time and store these values into the module’s memory.** Then the host computer can send out the “\$AA4, read synchronize data” command to read this data separately

4.4 Dual WatchDog Operation Principle

All 7521 series modules are equipped with hardware module watchdog and software host watchdog. The 7521 series are designed for industry applications, therefore they are able to work in harsh environments. There is much couple noise or energy transient in such an environment. The modules may shut down if this noise is too large. **The built-in hardware module watchdog can reset the module if it is down due to too large a signal.** Sometimes, even the host-PC may shut down for hardware or software reasons. The software host watchdog can monitor the status of host-PC. **If the host-PC is down, all the output of the 7521 series modules will go to their predefined safe states for safety protection.**

If the RS-485 **network is open**, all the host commands cannot be sent to remote modules. This is very dangerous in real world application. The output module of the 7521 series will force their output to go to their predefined safe state for safety consideration if the host watchdog is enabled. **This dual watchdog feature will increase the system reliability a great deal.**

4.5 Host WatchDog Applications Notes

The software host watchdog is designed to monitor the host computer. If the host computer fails, the output of the 7521 series will automatically go to their safe states to avoid unnecessary damage. The flow chart for the host computer is given as follows.

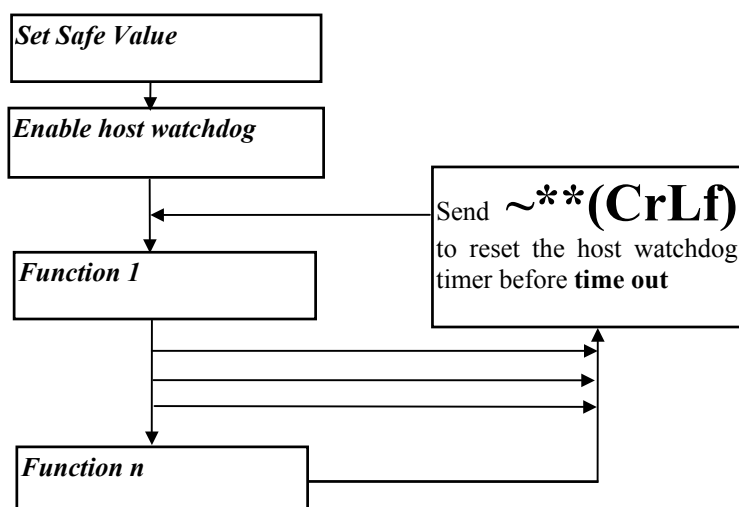

4.6 Module WatchDog Applications Notes

The “\$AA5” command is designed to detect the module hardware watchdog failure. If the module is down, the module hardware watchdog circuit will reset this module. **After reset the output state of module will go to their start-values. The start-value may be different from those output-value before module reset.** Therefore the user needs to send output commands again to the module to maintain the same output state before and after module watchdog reset.

The flow chart for module hardware watchdog failure detection is given as follows.

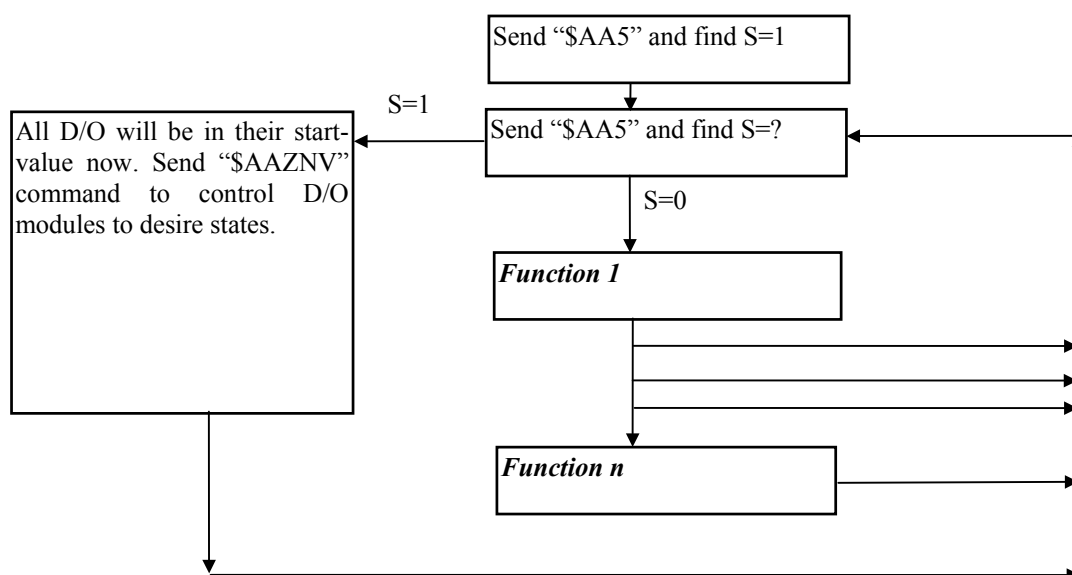

4.7 Source Code of the 7521/7522/7523

1. The source codes of the 7521 are given in the companion CD. User can modify these files for individual applications. All source codes are well-documented, so the user can change code easily. (Use BC to compile & link)
2. There are two files, autoexec.bat & 7521.EXE, stored in the flash ROM of the 7521. So the 7521.EXE will be executed after the power is supplied & the DI1/INIT* pin is floating. It is also similar for the 7522 & 7523.
3. There are some ODM programs are provided for the 7521. Refer to the readme.doc for more information. These ODM programs are given as follows:
 - 7521ODM1.c : 7521 + real time control D/IO
 - 7521ODM2.c : 7521 + real time control AD&DA
 - 7521ODM3.c : 7521 + real time control Event counter
 - 7521ODM4.c : 7521 + real time control Sensor & Multiplex
 - 7522ODM5.c : 7522 + real time monitor HP34401A & alarm controlMore ODM functions will be available in the future.