

# A-626 / 628

---

## User's Manual

### **Warranty**

All products manufactured by ICP DAS are warranted against defective materials for a period of one year from the date of delivery to the original purchaser.

### **Warning**

ICP DAS assume no liability for damages consequent to the use of this product. ICP DAS reserves the right to change this manual at any time without notice. The information furnished by ICP DAS is believed to be accurate and reliable. However, no responsibility is assumed by ICP DAS for its use, nor for any infringements of patents or other rights of third parties resulting from its use.

### **Copyright**

Copyright 1997 by ICP DAS. All rights are reserved.

### **Trademark**

The names used for identification only may be registered trademarks of their respective companies.

### **License**

The user can use, modify and backup this software **on a single machine**. The user may not reproduce, transfer or distribute this software, or any copy, in whole or in part.

## **CONTENTS**

<b><u>1. INTRODUCTION</u></b>	<b><u>4</u></b>
1.1. FEATURES	4
1.2. APPLICATIONS	4
1.3. SPECIFICATIONS	5
<b><u>2. INSTALL A-626 / A-628</u></b>	<b><u>6</u></b>
2.1. PRODUCT CHECK LIST	6
2.2. JUMPER AND DIP SWITCH SETTING	6
2.3. LAYOUT	7
2.3.1 A-628'S LAYOUT	7
2.3.2 A-626'S LAYOUT	8
2.4. I/O ADDRESS SETTING	9
2.4.1. A-626 ADDRESS SETTING	9
2.4.2. A-628 ADDRESS SETTING	11
2.4.3. I/O ADDRESS MAPPING	12
2.5. JUMPER SETTING	13
2.5.1. A-626 JUMPER SETTING	13
2.5.2. A-628 JUMPER SETTING	14
2.5.3. REFERENCE VOLTAGE TABLE	15
2.6. PIN ASSIGNMENT	16
2.7. SIGNAL CONNECTION	19
2.7.1. VOLTAGE OUTPUT	19
2.7.2. CURRENT LOOP	19
<b><u>3. PROGRAMMING</u></b>	<b><u>20</u></b>
3.1. I/O REGISTER	20
3.1.1. A-626 I/O PORT ADDRESS	20
3.1.2. A-626 D/A REGISTER	20
3.1.3. A-628 I/O PORT ADDRESS	21
3.1.4. A-628 D/A REGISTER	21
3.2. DATA REGISTER	22
3.3. DIGITAL INPUT / OUTPUT REGISTER	25

***4. CALIBRATION*** ***26***

---

***5. TERMINAL BOARD*** ***28***

---

<b>5.1. DB-16P ISOLATED INPUT BOARD</b>	<b>28</b>
<b>5.2. DB-16R RELAY BOARD</b>	<b>29</b>
<b>5.3. DB-24PR POWER RELAY BOARD</b>	<b>30</b>
<b>5.4. DB-8125 SCREW TERMINAL BOARD</b>	<b>31</b>
<b>5.5. DN-37 (D-SUB I/O CONNECTOR BLOCK WITH DIN RAIL MOUNTING)</b>	<b>32</b>

---

# 1. Introduction

The A-626 / A-628 Provides 6 / 8 Channel analog outputs, 16 channel digital outputs and 16 channel inputs . Each analog output channel can be user configurable, range of : Voltage output : 0 ~ 5 V, 0 ~ 10 V,  $\pm 5$  V,  $\pm 10$  V or Current loop : 4 ~ 20 mA . The A-626/ A628 has 16 channel digital input and digital output . All the D/I/O channel are TTL compatible. and it can connection with DB-16P (16 channel isolation digital input board) or DB-16R(16 Channel Relay output board) daughter board.

---

## 1.1. Features

- A-626 6 Channel analog output  
A-628 8 Channel analog output
- 12-bit resolution, double buffered D/A converter
- Voltage range : 0 ~ 5 V, 0 ~ 10 V,  $\pm 5$  V,  $\pm 10$  V
- Current loop : 4 ~ 20 mA
- IRQ level : IRQ3 ~ IRQ15
- 16 Channel Digital Output
- 16 Channel Digital Input
- D/I/O are TTL Compatible

---

## 1.2. Applications

- Servo control
- On/Off control
- Energy management
- Programmable current sink

## 1.3. Specifications

Model Name	A-626	A-628
<b>Analog Output</b>		
Channels	6	8
Resolution	12-bit	
Accuracy	0.01 % of FSR $\pm$ 1 LSB @ 25 °C, $\pm$ 10 V	
Output Range	Unipolar: 0 ~ 5 V, 0 ~ 10 V Bipolar: $\pm$ 5 V, $\pm$ 10 V	
Output Driving	$\pm$ 5 mA	
Slew Rate	0.6 V/ $\mu$ s	
Output Impedance	0.1 $\Omega$ max.	
Operating Mode	Software	
<b>Digital Input</b>		
Channels	16	
Compatibility	5 V/TTL	
Input Voltage	Logic 0: 0.8 V max. Logic 1: 2.0 V min.	
Response Speed	1.0 MHz (Typical)	
<b>Digital Output</b>		
Channels	16	
Compatibility	5 V/TTL	
Output Voltage	Logic 0: 0.4 V max. Logic 1: 2.4 V min.	
Output Capability	Sink: 0.8 mA @ 0.8 V Source: -2.4 mA @ 2.0 V	
Response Speed	1.0 MHz (Typical)	
<b>General Environmental</b>		
Bus Type	ISA	
I/O Connector	Female DB37 x 1 20-pin box header x 2	
Dimensions (L x W x D)	157 mm x 106 mm x 22 mm	
Power Consumption	0.9 A @ +5 V (Max.) 110 mA @ +12 V (Max.) 90 mA @ -12 V (Max.)	1.1 A @ +5 V (Max.) 130 mA @ +12 V (Max.) 105 mA @ -12 V (Max.)
Operating Temperature	0 ~ 60 °C	
Storage Temperature	-20 ~ 70 °C	
Humidity	5 ~ 85% RH, non-condensing	

---

## 2. Install A-626 / A-628

---

### 2.1. Product Check List

The package includes the following items:

- One piece of A-626 / A-628 Analog output Card
- One company floppy diskette or CD
- One Quick Start Guide

#### **Attention !**

If any of these items is missing or damaged, contact the dealer who provides you this product. Save the shipping materials and carton in case you want to ship or store the product in the future.

The A-626 / A-628 Card contain sensitive electronic components that can be easily damaged by static electricity.

The card should be protection on a grounded anti-static mat. and operator should be wearing an a grounded anti-static wristband.

---

### 2.2. Jumper and DIP Switch Setting

When you use the A-626 / A-628, You should set the I/O address and voltage range first. You can configure output voltage of each channel and I/O address by jumper and switch.

The position of jumper please refer the section 2.3 A-626 / A-628 layout

## 2.3. Layout

### 2.3.1 A-628's Layout

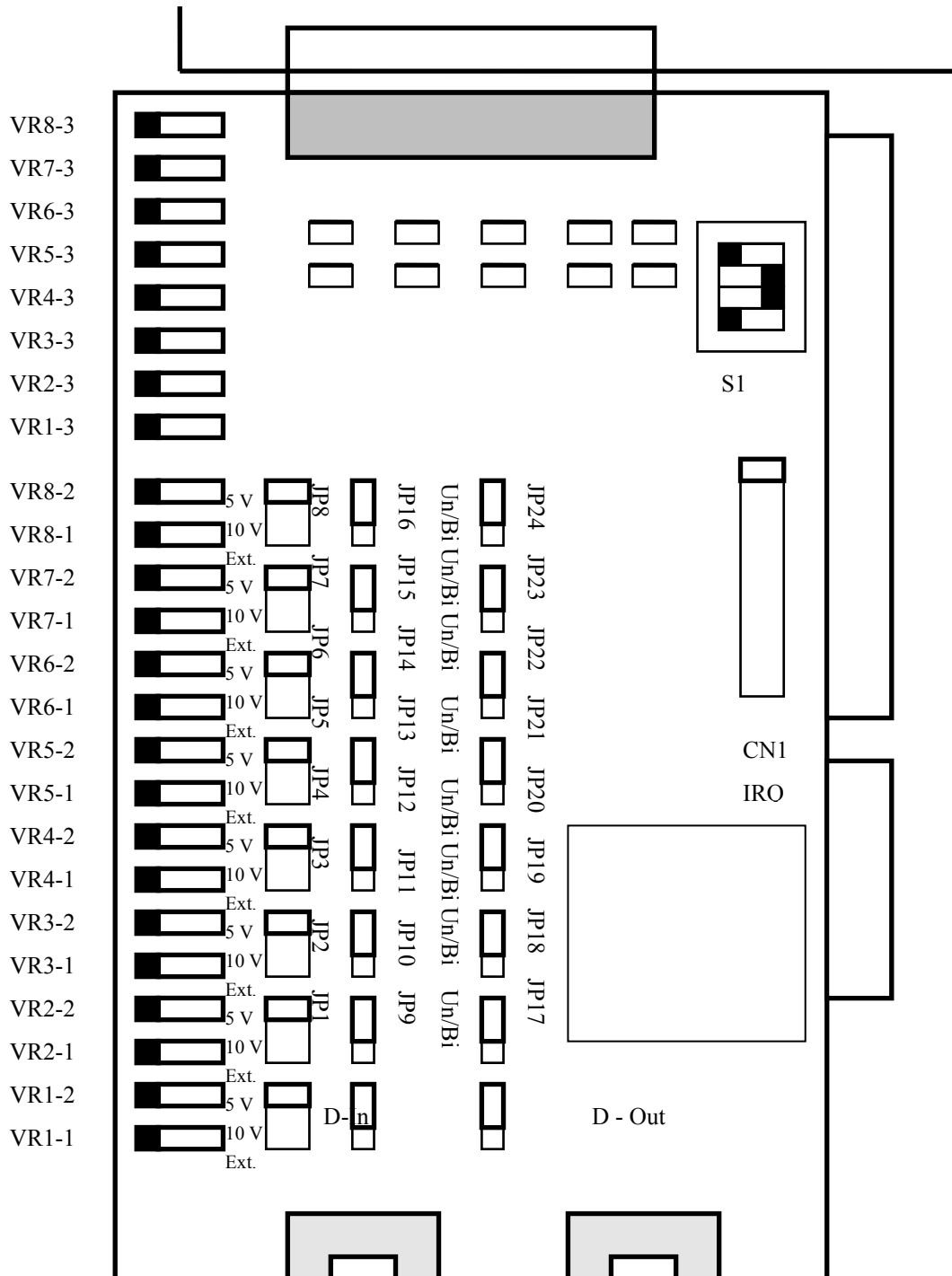

**Note:**

Un :Unipolar

JPn : Jumper Number

Ext. :External

S : Dip Switch

Bi :Bipolar

VR :Veritable Resistor

CN : Connector

## 2.3.2 A-626's Layout

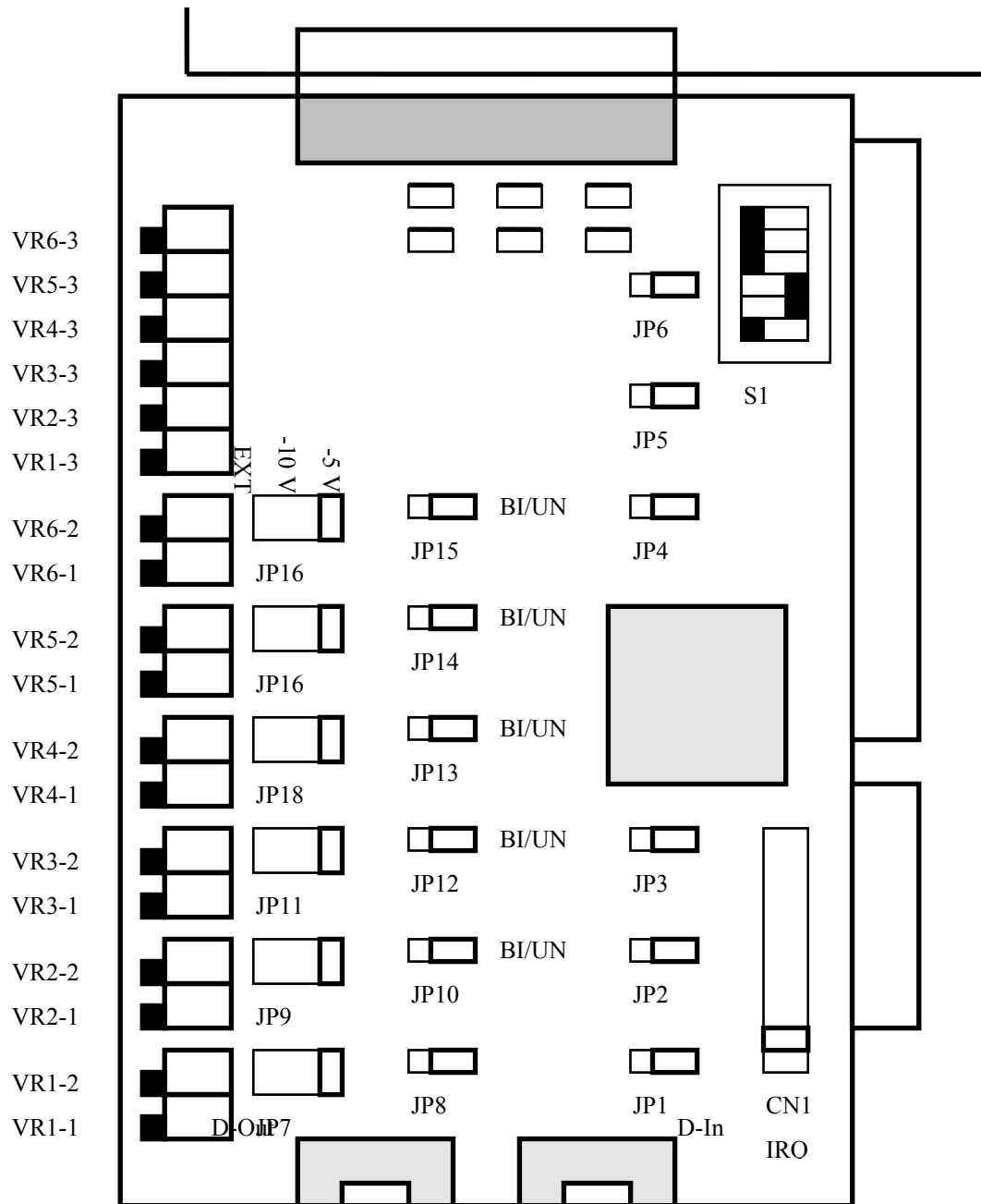

**Note :**

- UN      Unipolar
- BI      Bipolar
- 5 V    Internal Reference Voltage -5 V
- 10 V   Internal Reference Voltage -10 V
- EXT    External Reference Voltage Input

---

## 2.4. I/O Address Setting

### 2.4.1. A-626 Address Setting

The A-626 requires consecutive locations in I/O address space. The base address is set by DIP switch S1. The default address is 2C0 Hex.

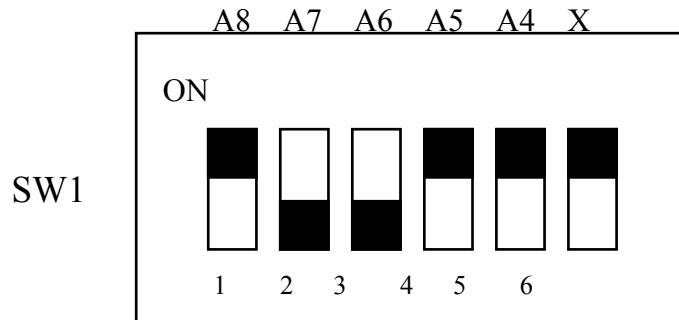

Default Base Address 2C0 Hex

### For Example

### How to select 2 C 0 (Hex)

OFF → 1  
ON → 0

<b>2</b>		<b>C</b>				<b>0</b>
<b>1</b>	ON	OFF	OFF	ON	ON	X
	→ <b>0</b>	<b>1</b>	<b>1</b>	<b>0</b>	<b>0</b>	<b>X</b>
	A8	A7	A6	A5	A4	X

The detail SW1 base addresses setting. Please refer to **A-626 Base Address Table**.

## A-626 Base Address Table:

Base Adders	1 A8	2 A7	3 A6	4 A5	5 A4	6 X
200-20F	ON	ON	ON	ON	ON	X
210-21F	ON	ON	ON	ON	OFF	X
220-22F	ON	ON	ON	OFF	ON	X
230-23F	ON	ON	ON	OFF	OFF	X
240-24F	ON	ON	OFF	ON	ON	X
250-25F	ON	ON	OFF	ON	OFF	X
260-26F	ON	ON	OFF	OFF	ON	X
270-27F	ON	ON	OFF	OFF	OFF	X
280-28F	ON	OFF	ON	ON	ON	X
290-29F	ON	OFF	ON	ON	OFF	X
2A0-2AF	ON	OFF	ON	OFF	ON	X
2B0-2BF	ON	OFF	ON	OFF	OFF	X
<b>2C0-2CF(*)</b>	<b>ON</b>	<b>OFF</b>	<b>OFF</b>	<b>ON</b>	<b>ON</b>	<b>X</b>
2D0-2DF	ON	OFF	OFF	ON	OFF	X
2E0-2EF	ON	OFF	OFF	OFF	ON	X
2F0-2FF	ON	OFF	OFF	OFF	OFF	X
300-30F	OFF	ON	ON	ON	ON	X
310-31F	OFF	ON	ON	ON	OFF	X
320-32F	OFF	ON	ON	OFF	ON	X
330-33F	OFF	ON	ON	OFF	OFF	X
340-34F	OFF	ON	OFF	ON	ON	X
350-35F	OFF	ON	OFF	ON	OFF	X
360-36F	OFF	ON	OFF	OFF	ON	X
370-37F	OFF	ON	OFF	OFF	OFF	X
380-38F	OFF	OFF	ON	ON	ON	X
390-39F	OFF	OFF	ON	ON	OFF	X
3A0-3AF	OFF	OFF	ON	OFF	ON	X
3B0-3BF	OFF	OFF	ON	OFF	OFF	X
3C0-3CF	OFF	OFF	OFF	ON	ON	X
3D0-3DF	OFF	OFF	OFF	ON	OFF	X
3E0-3EF	OFF	OFF	OFF	OFF	ON	X
3F0-3FF	OFF	OFF	OFF	OFF	OFF	X

\* Default Base Address is 2C0 Hex

---

## 2.4.2. A-628 Address Setting

The A-628 requires 20 consecutive locations in I/O address space. The base address is set by DIP switch S1. The default address is 2C0 Hex.

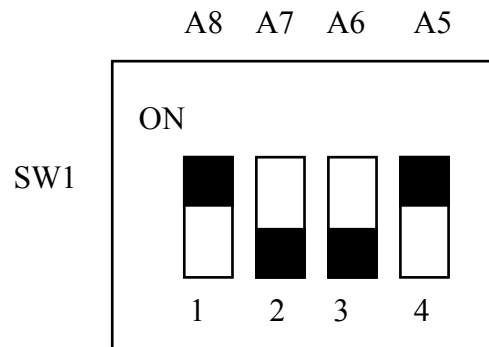

Default Base Address: 2C0 Hex

### For Example

### How to select 2 C 0 (Hex)

OFF → 1  
ON → 0

<b>2</b>		<b>C</b>			<b>0</b>
<b>1</b>	ON	OFF	OFF	ON	<b>0</b>
	→ <b>0</b>	<b>1</b>	<b>1</b>	<b>0</b>	
	A8	A7	A6	A5	

The detail SW1 base addresses setting. Please refer to **A-628 Base Address Table**.

## A-628 Base Address Table:

Base Address	1 A8	2 A7	3 A6	4 A5
200-21F	ON	ON	ON	ON
220-23F	ON	ON	ON	OFF
240-25F	ON	ON	OFF	ON
260-27F	ON	ON	OFF	OFF
280-29F	ON	OFF	ON	ON
2A0-2BF	ON	OFF	ON	OFF
<b>2C0-2DF(*)</b>	<b>ON</b>	<b>OFF</b>	<b>OFF</b>	<b>ON</b>
2E0-2FF	ON	OFF	OFF	OFF
300-31F	OFF	ON	ON	ON
320-33F	OFF	ON	ON	OFF
340-35F	OFF	ON	OFF	ON
360-37F	OFF	ON	OFF	OFF
380-39F	OFF	OFF	ON	ON
3A0-3BF	OFF	OFF	ON	OFF
3C0-3DF	OFF	OFF	OFF	ON
3E0-3FF	OFF	OFF	OFF	OFF

\* Default Base Address is 2C0 Hex

### 2.4.3. I/O Address Mapping

Address	Device	Address	Device
000-1FF	PC RESERVED	320-32F	XT Hart Dosk
200-20F	Game Port	378-37F	Parallel Port
210-21F	XT Expansion Unit	380-38F	SDLC
238-23F	Bus Mouse	3A0-3AF	SDLC
278-27F	Parallel Port	3B0-3BF	MDA/Parallel Port
2B0-2DF	EGA	3C0-3CF	EGA
2E0-2E7	AT GPIB	3D0-3DF	CGA
2E8-2EF	Serial Port	3E0-3EF	Serial Port
2F8-2EF	Serial Port	3F0-3F7	Floppy Disk
300-31F	Prototype Card	3F8-3FF	Serial Port

---

## 2.5. Jumper Setting

### 2.5.1. A-626 Jumper Setting

The A-626 each D/A channel can be configurable. You can set the voltage range for your applications.

The A-626 provides -5 V or -10 V internal reference voltage and unipolar or bipolar voltage output. Each channel is individually jumper selectable to any ranges.

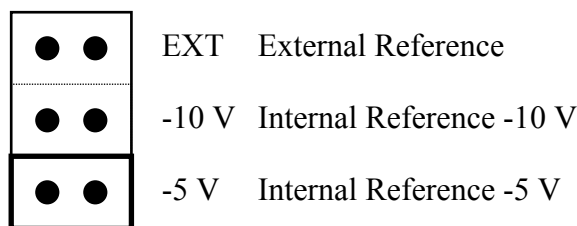

**Jumper Number: JP7 , JP9 , JP 11, JP18 , JP17 , JP16**

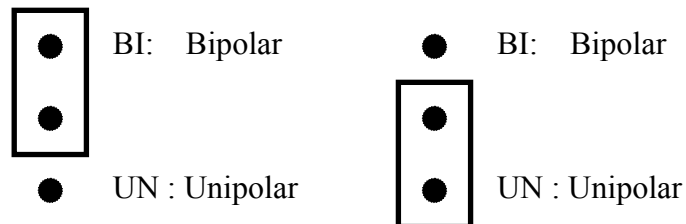

**Jumper Number : JP8 , JP10 , JP12 , JP13 , JP14 , JP15**

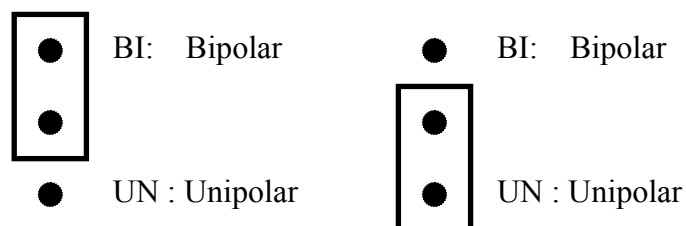

**Jumper Number :JP1 , JP2 , JP3 , JP4 , JP5 , JP5 , JP6**

---

## 2.5.2. A-628 Jumper Setting

The A-628 each D/A channel can be configurable. You can set the voltage range for your applications.

The A-628 provides -5 V or -10 V internal reference voltage and unipolar or bipolar voltage output . Each channel is individually jumper selectable to any ranges.

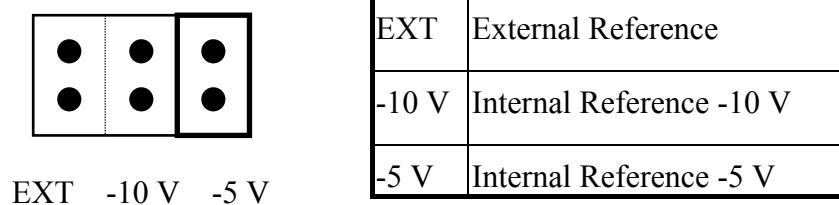

### Jumper Number: JP1 , JP2 , JP3, JP4 , JP5 , JP6 , JP7 , JP8



### Jumper Number : JP9 , JP10 , JP11 , JP12 , JP13 , JP14 , JP15 , JP16



### Jumper Number :JP17 , JP18 , JP19 , JP20 , JP21 , JP22 , JP23 , JP24

## 2.5.3. Reference Voltage Table

**Reference Voltage Table**

Reference Voltage	Unipolar	Bipolar
-5 V Reference	0 ~ 5 V	±5 V
-10 V Reference	0 ~ 10 V	±10 V
External Reference	0~ - (Ext. Reference Voltage)	(Ext.. Reference Voltage) ~ -(Ext. Reference Voltage)

**Voltage Range Table**

Voltage Range	Reference Voltage	Unipolar / Bipolar
0 ~ 5 V	-5 V	Unipolar
0~10 V	-10 V	Unipolar
± 5 V	-5 V	Bipolar
± 10 V	-10 V	Bipolar
4 ~ 20 mA Current loop	-5 V	unipolar

**A-626 Jumper Setting Table**

D/A Channel	Corresponding Jumper Unipolar/Bipolar	Corresponding Jumper Reference Voltage
Channel 0	JP 1 & JP 8	JP 7
Channel 1	JP 2 & JP10	JP 9
Channel 2	JP 3 & JP12	JP11
Channel 3	JP 4 & JP13	JP18
Channel 4	JP 5 & JP14	JP17
Channel 5	JP 6 & JP15	JP16

**A-628 Jumper Setting Table**

D/A Channel	Corresponding Jumper Reference Voltage	Corresponding Jumper Unipolar/Bipolar
Channel 0	JP 1	JP 9 & JP17
Channel 1	JP 2	JP 10 & JP18
Channel 2	JP 3	JP 11 & JP19
Channel 3	JP 4	JP 12 & JP20
Channel 4	JP 5	JP 13 & JP21
Channel 5	JP 6	JP 14 & JP22
Channel 6	JP 7	JP 15 & JP23
Channel 7	JP 8	JP 16 & JP24

## 2.6. Pin Assignment

### A-626 P1: 37-Pin Connector for Voltage Output & Current Loop

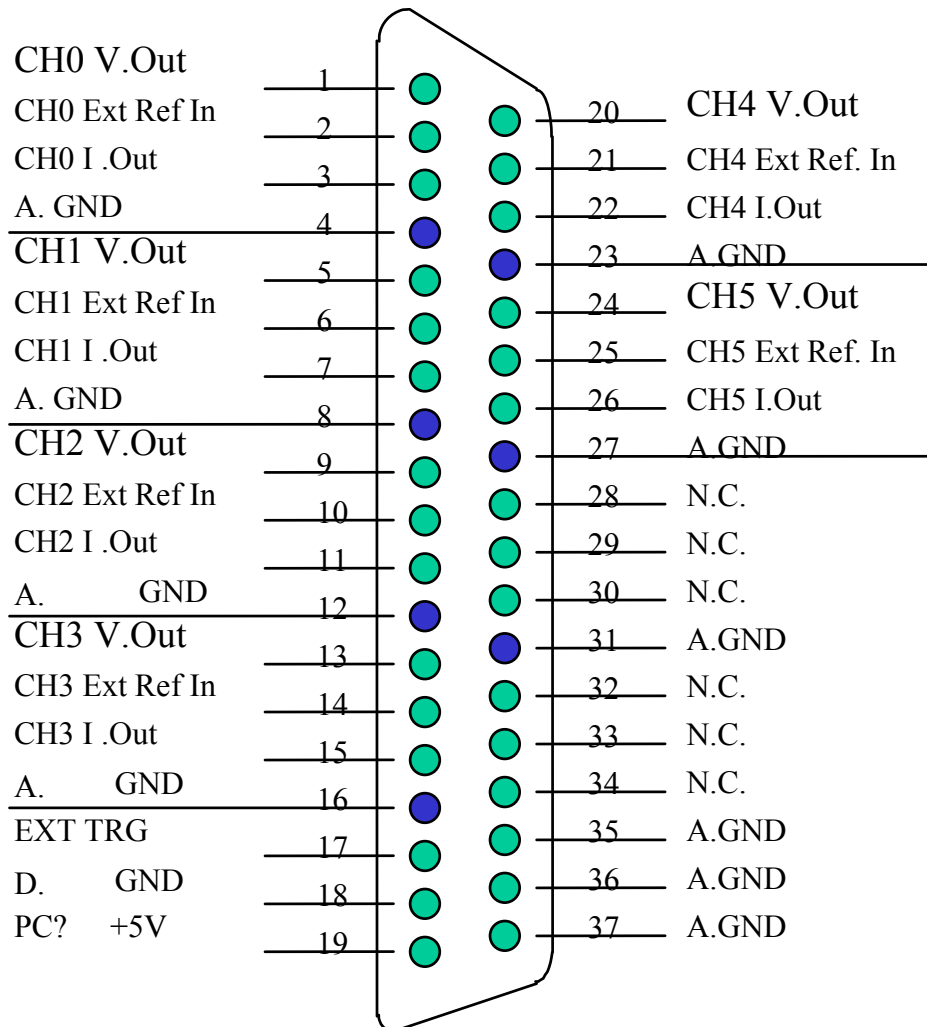

#### Note :

- CH n V.Out                    D/A Voltage Output Channel n
- CH n Ext Ref In            D/A External Reference Input Channel n
- CH n I. Out                    Current Loop Output Channel n
- A. GND                         Analog Ground
- D.GND                         Digital Ground
- PC's +5 V                    From PC Power Supply +5 V

---

A-628 CN1: 37-Pin Connector for Voltage Output & Current Loop

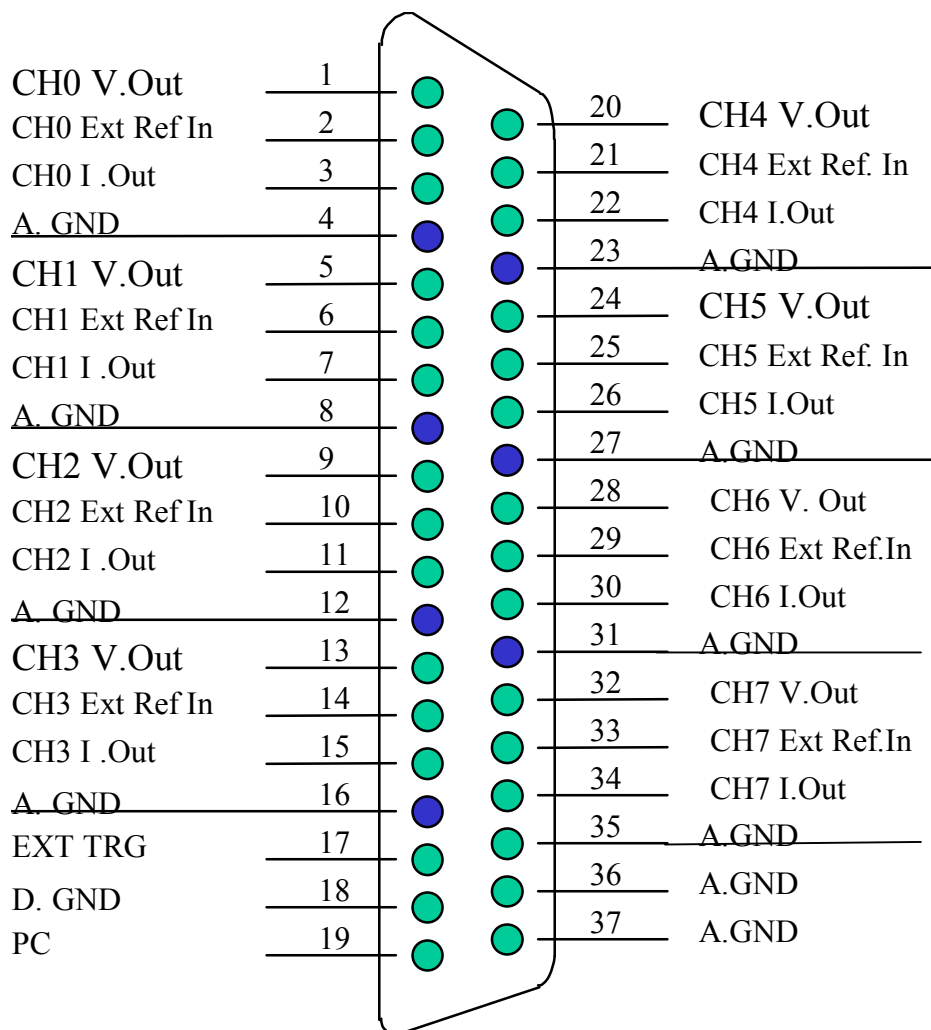

Note :

- CH n V.Out                    D/A Voltage Output Channel n
- CH n Ext Ref In            D/A External Reference Input Channel n
- CH n I. Out                    Current Loop Output Channel n
- A.GND                          Analog Ground
- D.GND                          Digital Ground
- PC's +5 V                      From PC Power Supply +5 V

---

A-626 CN3: Digital Output Connector

A-628 CN2 : Digital Output connector

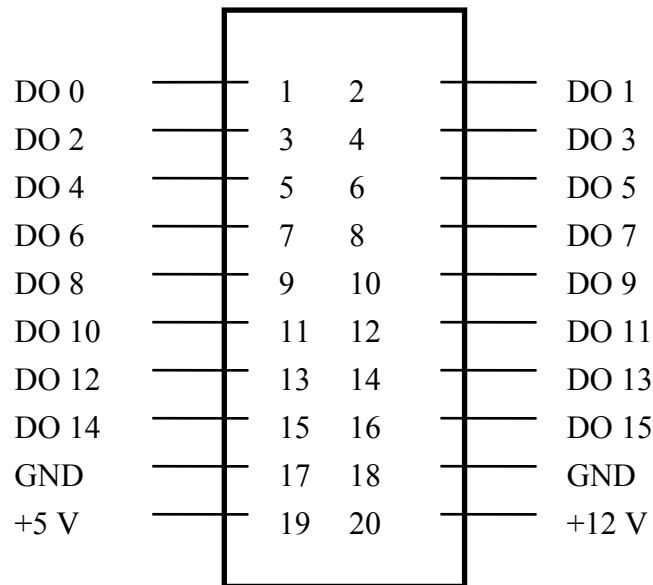

The A-626 / A-628 has 16 channel digital output /Input , all of the digital channels are TTL compatible.

The DB-16R ( 16 Channel Relay Actuator Board) or DB-24PR (24 Channel Power Relay Actuator Board) and DB-16P (16Channel Isolation Input Board) are designed for going with the digital input and output connector

A-626 CN4: Digital Input Connector

A-628 CN3 : Digital Input Connector

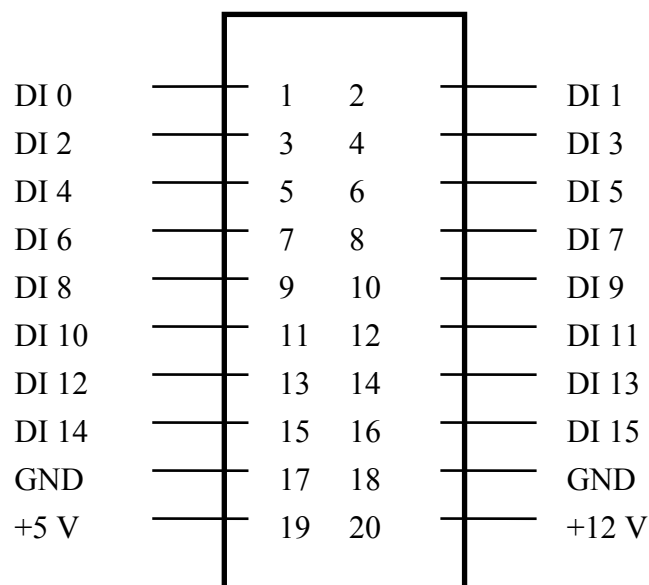

---

## 2.7. Signal Connection

### 2.7.1. Voltage Output

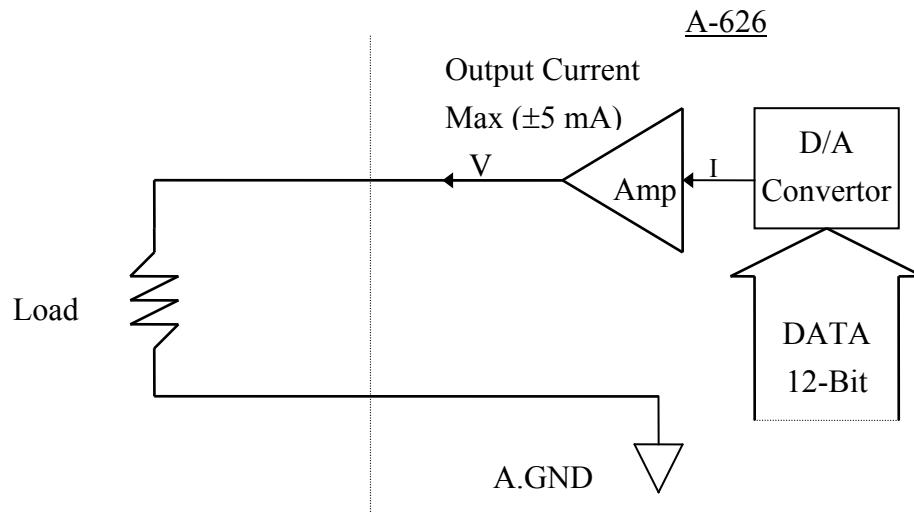

The A-626 / A-628 D/A Voltage Output Maximum Current :  $\pm 5$  mA

### 2.7.2. Current Loop

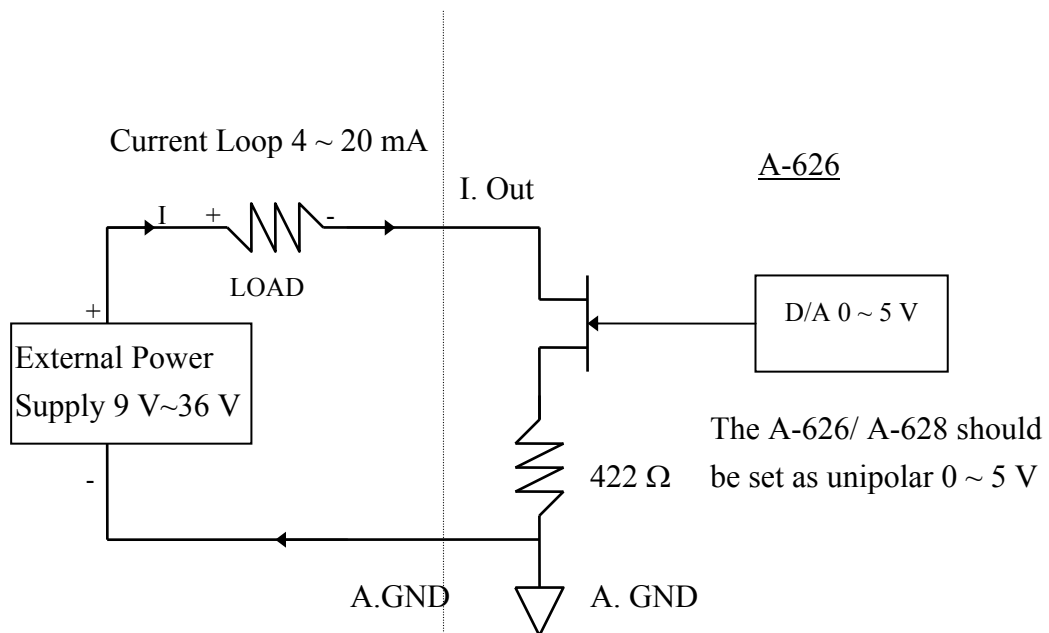

---

## 3. Programming

---

### 3.1. I/O Register

#### 3.1.1. A-626 I/O Port Address

Address	Function	Read/Write
Base + 0x0	D/A CH0 High Byte	Write
Base + 0x1	D/A CH0 Low Byte	Write
Base + 0x2	D/A CH1 High Byte	Write
Base + 0x3	D/A CH1 Low Byte	Write
Base + 0x4	D/A CH2 High Byte	Write
Base + 0x5	D/A CH2 Low Byte	Write
Base + 0x6	D/A CH3 High Byte	Write
Base + 0x7	D/A CH3 Low Byte	Write
Base + 0x8	D/A CH4 High Byte	Write
Base + 0x9	D/A CH4 Low Byte	Write
Base + 0xA	D/A CH5 High Byte	Write
Base + 0xB	D/A CH5 Low Byte	Write
Base + 0xC	D/O Bit 8-15	Write
Base + 0xD	D/O Bit 0 - 7	Write
Base + 0xE	D/I Bit 8- 15	Read
Base + 0xF	D/I Bit 0 - 7	Read

#### 3.1.2. A-626 D/A Register

D/A Channel	High Byte Address	Low Byte Address
0	Base + 0	Base + 1
1	Base + 2	Base + 3
2	Base + 4	Base + 5
3	Base + 6	Base + 7
4	Base + 8	Base + 9
5	Base + A	Base + B

---

### 3.1.3. A-628 I/O Port Address

Address	Function	Read/Write
Base + 0x0	D/A CH0 High Byte	Write
Base + 0x1	D/A CH0 Low Byte	Write
Base + 0x2	D/A CH1 High Byte	Write
Base + 0x3	D/A CH1 Low Byte	Write
Base + 0x4	D/A CH2 High Byte	Write
Base + 0x5	D/A CH2 Low Byte	Write
Base + 0x6	D/A CH3 High Byte	Write
Base + 0x7	D/A CH3 Low Byte	Write
Base + 0x8	D/A CH4 High Byte	Write
Base + 0x9	D/A CH4 Low Byte	Write
Base + 0xA	D/A CH5 High Byte	Write
Base + 0xB	D/A CH5 Low Byte	Write
Base + 0xC	D/A CH6 High Byte	Write
Base + 0xD	D/A CH6 Low Byte	Write
Base + 0xE	D/A CH7 High Byte	Write
Base + 0xF	D/A CH7 Low Byte	Write
Base + 0x10	D/I/O Bit 0 ~ 7	Read/Write
Base + 0x11	D/I/O Bit 8 ~ 15	Read/Write

### 3.1.4. A-628 D/A Register

D/A Channel	High Byte Address	Low Byte Address
0	Base + 0x0	Base + 0x1
1	Base + 0x2	Base + 0x3
2	Base + 0x4	Base + 0x5
3	Base + 0x6	Base + 0x7
4	Base + 0x8	Base + 0x9
5	Base + 0xA	Base + 0xB
6	Base + 0xC	Base + 0xD
7	Base + 0xE	Base + 0xF

---

## 3.2. Data Register

### 12-bit D/A Data Format:

D/A Low Byte							
Bit 7	Bit 6	Bit 5	Bit 4	Bit 3	Bit 2	Bit 1	Bit 0
D7	D6	D5	D4	D3	D2	D1	D0

D/A High Byte							
Bit 7	Bit 6	Bit 5	Bit 4	Bit 3	Bit 2	Bit 1	Bit 0
X	X	X	X	D11	D10	D9	D8

Note: You should be write the high byte data first then write low byte data

Example : (Basic Language)

Bas=&h2c0

OUT bas+0,&H80           ` send High byte

OUT bas+1,&H0           ` send Low byte

    `Unipolar 0 ~ 5 V D/A Channel 0 will output 2.5 V

High Byte Data								Low Byte Data							
D7	D6	D5	D4	D3	D2	D1	D0	D7	D6	D5	D4	D3	D2	D1	D0
X	X	X	X	11	10	9	8	7	6	5	4	3	2	1	0

0x000	0	0	0	0	0	0	0	0	0	0	0	0	0	0	0
0x800	1	0	0	0	0	0	0	0	0	0	0	0	0	0	0
0xFFFF	1	1	1	1	1	1	1	1	1	1	1	1	1	1	1

12 Bit Data

Output Range	Output Voltage	Binary Code	Hex.	Dec.
	5 V	1111 1111 1111	FFF	4095
0 ~ 5 V	2.5 V	1000 0000 0000	800	2048
(Unipolar)	0 V	0000 0000 0000	0	0
	10 V	1111 1111 1111	FFF	4095
0 ~ 10 V	5 V	1000 0000 0000	800	2048
(Unipolar)	0 V	0000 0000 0000	0	0
	5 V	1111 1111 1111	FFF	4095
±5 V	0 V	1000 0000 0000	800	2048
(Bipolar)	-5 V	0000 0000 0000	0	0
	10 V	1111 1111 1111	FFF	4095
±10 V	0 V	1000 0000 0000	800	2048
(Bipolar)	-10 V	0000 0000 0000	0	0
	20 mA	1111 1111 1111	FFF	4095
4 ~ 20 mA	12 mA	1000 0000 0000	800	2048
(Current Loop)	4 mA	0000 0000 0000	0	0

0 V	(0 ~ 5 V)	2.5 V	5 V
0 V	(0 ~ 10 V)	5 V	10 V
-5 V	(±5 V)	0 V	+5 V
-10 V	(±10 V)	0 V	+10 V
4 mA	(4 ~ 20 mA)	12 mA	20 mA

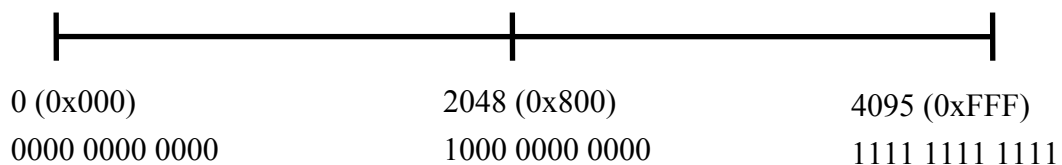

### 12 bit Data Format

---

**Calculation :**

$$VD = \text{High Byte} \times 256 + \text{Low Byte}$$

**Unipolar :**

VD = 2050 (Dec.) Converted Data  
High Byte = 8 , Low Byte = 2  
Output Range : 0 ~ 5 V  
Voltage Output = 5 (V)  $\times$  2050 / 4095 = 2.503 (V)

**Bipolar :**

Coveted Data = 1024 (Dec.)  
High Byte = 4 , Low Byte = 0  
Output Range =  $\pm$ 10 V  
Voltage Output = 5 (V)  $\times$  (1024-2048)/2048 = - 2.4926 (V)

**Current Loop:**

Coveted Data = 3076 (Dec)  
High Byte = 12 , Low Byte = 4  
Output Range = 4 ~ 20 mA  
Current Sink = ((20-4)  $\times$  3076/4095 )+ 4=16.0185 (mA)

**Example Program : ( Quick Basic)**

```
BasAddress=&H2C0          ' A-626 / A-628 Base Address
RefVol=5                  ' Reference Voltage = -5 V
                           ( Unipolar 0 ~ 5 V )
Vo = 3.5                  ' Output 3.5 V

Vd = int(Vo*4095/Refvol)  ' Conversion Binary Data
HighByte = int(Vd/256)    ' High Byte Data
LowByte = Vd - HighByte*256 ' Low Byte Data

OUT ( BasAddress + 0 , HighByte) ' Write high byte data first
OUT ( BasAddress + 1 , LowByte)  ' Then low byte data to D/A channel 0
```

## 3.3. Digital Input / Output Register

### A-626 Digital Input / Output Register

Address	Write	Read
Base + 0x0C	Digital Output Channel 0 ~ 7	Digital Input Channel 0 ~ 7
Base + 0x0D	Digital Output Channel 8 ~ 15	Digital Input Channel 8 ~ 15

### Digital Input / Output Data Format

Bit	7	6	5	4	3	2	1	0
Base + C	DO15	DO14	DO13	DO12	DO11	DO10	DO9	DO8
Base + D	DO7	DO6	DO5	DO4	DO3	DO2	DO1	DO0
Base + C	DI15	DI14	DI13	DI12	DI11	DI10	DI9	DI8
Base + D	DI7	DI6	DI5	DI4	DI3	DI2	DI1	DI0

### A-628 Digital Input / Output Register

Address	Write	Read
Base + 0x10	Digital Output Channel 0 ~ 7	Digital Input Channel 0 ~ 7
Base + 0x11	Digital Output Channel 8 ~ 15	Digital Input Channel 8 ~ 15

### Digital Input / Output Data Format

Bit	7	6	5	4	3	2	1	0
Base + 0x10	DO 7	DO 6	DO 5	DO 4	DO 3	DO 2	DO 1	DO 0
Base + 0x11	DO 15	DO 14	DO 13	DO 12	DO 11	DO 10	DO 9	DO 8
Base + 0x10	DI 7	DI 6	DI 5	DI 4	DI 3	DI 2	DI 1	DI 0
Base + 0x11	DI 15	DI 14	DI 13	DI 12	DI 11	DI 10	DI 9	DI 8

Digital Input / Output Example program .

#### A-626 For Basic Language

Bas = &H2C0

Out Bas + &HC , &HFF

‘ Write Data to Channel 0 ~ 7 of Digital Output

Out Bas + &HD , &HFF

‘ Write Data to Channel 8 ~ 15 of Digital Output

DIL = INP(Bas + &HC)

‘ Read Channel 0 ~ 7 of Digital Input

DIL = INP(Bas + &HD)

‘ Read Channel 8 ~ 15 of Digital Input

---

## 4. Calibration

The each channel of A-626 /A-628 has three VR can be adjust to current value.

**A-626 VR's Table**

D/A Channel	Unipolar Full Scale	Bipolar Off-set	Current loop 4mA
0	VR1-2	VR1-1	VR1-3
1	VR2-2	VR2-1	VR2-3
2	VR3-2	VR3-1	VR3-3
3	VR4-2	VR4-1	VR4-3
4	VR5-2	VR5-1	VR5-3
5	VR6-2	VR6-1	VR6-3

### Calibration step:

#### A. Unipolar (0 ~ 5 V)

1. You need a 6 1/2 digital voltage meter.
2. Set D/A channel : (1) Unipolar mode. (2) Reference Voltage : -5 V
3. Connect DVM to D/A Channel 0
4. Write 0xFFFF (Hex) Data to D/A Channel 0
5. Trim VR1-2 until the DVM reading 4.9988 V

#### B. Bipolar ( $\pm 5$ V)

1. Set D/A channel : (1) Bipolar mode. (2) Reference Voltage : -5 V
2. Connect DVM to D/A Channel 0
3. Write 0x800 (Hex) Data to D/A Channel 0
4. Trim VR1-1 until the DVM reading 0.0000 V
5. Write 0xFFFF (Hex) to D/A Channel 0
6. Trim VR1-2 until the DVM reading 4.9988 V

#### C. Current loop 4 ~ 20 mA

1. Set D/A Channel : (1) Unipolar mode . (2) Reference Voltage : -5 V
2. Ref. Sec. 2.7 signal connection connect DAM to current loop channel
3. Write 0x000 (Hex) to D/A Channel 0
4. Trim VR1-3 until the DAM reading 4.0000 mA
5. Write 0xFFFF (Hex) to D/A Channel 0
6. Trim VR1-2 until the DAM reading 20 mA

---

## A-628 Calibration

The each channel of A-628 has three VR can be adjust to current value.

D/A Channel	Unipolar Full Scale	Bipolar Off-set	Current loop 4 mA
0	VR1-2	VR1-1	VR1-3
1	VR2-2	VR2-1	VR2-3
2	VR3-2	VR3-1	VR3-3
3	VR4-2	VR4-1	VR4-3
4	VR5-2	VR5-1	VR5-3
5	VR6-2	VR6-1	VR6-3
6	VR7-2	VR7-1	VR7-3
7	VR8-2	VR8-1	VR8-3

Calibration step:

### A. Unipolar (0 ~ 5 V)

1. You need a 6 1/2 digital voltage meter.
2. Set D/A channel : (1) Unipolar mode. (2) Reference Voltage : -5 V
3. Connect DVM to D/A Channel 0
4. Write 0xFFFF (Hex) Data to D/A Channel 0
5. Trim VR1-2 until the DVM reading 4.9988 V

### B. Bipolar ( $\pm 5$ V)

1. Set D/A channel : (1) Bipolar mode. (2) Reference Voltage : -5 V
2. Connect DVM to D/A Channel 0
3. Write 0x800 (Hex) Data to D/A Channel 0
4. Trim VR1-1 until the DVM reading 0.0000 V
5. Write 0xFFFF (Hex) to D/A Channel 0
6. Trim VR1-2 until the DVM reading 4.9988 V

### C. Current loop 4 ~ 20 mA

1. Set D/A Channel : (1) Unipolar mode . (2) Reference Voltage : -5 V
2. Ref. Sec. 2.7 signal connection connect DAM to current loop channel
3. Write 0x000 (Hex) to D/A Channel 0
4. Trim VR1-3 until the DAM reading 4.0000 mA
5. Write 0xFFFF (Hex) to D/A Channel 0
6. Trim VR1-2 until the DAM reading 20 mA

---

## 5. Terminal Board

---

### 5.1. DB-16P Isolated Input Board

The DB-16P is a 16 Channel isolated digital input daughter board .

The optically isolated inputs of the DB-16P consist of a bi-directional optocoupler with a resistor for current sensing. You can use the DB-16P to sense DC signal from TTL levels up to 24 V. Or use the DB-16P to sense a wide range of AC signals. You can use the board to isolate the computer from large common-mode voltages, ground loops and voltage spikes that often occur in industrial environments.

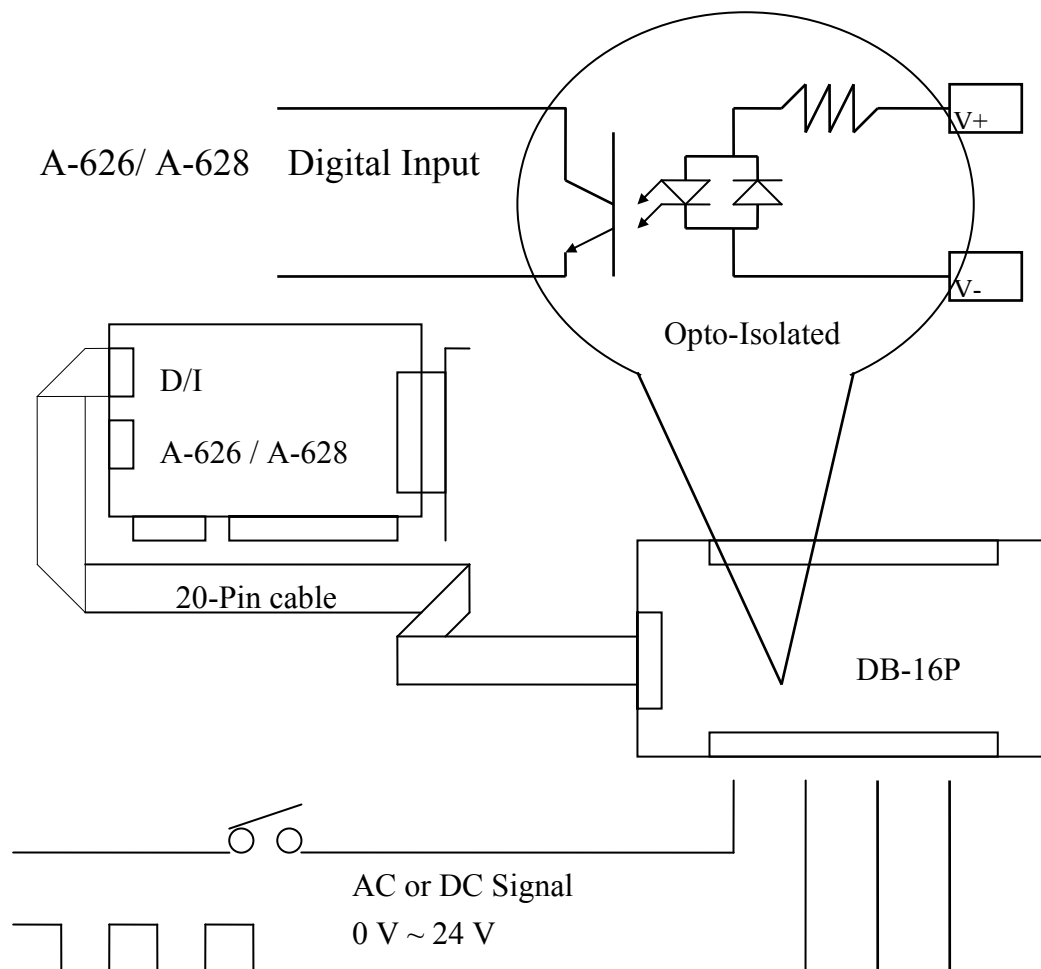

---

## 5.2. DB-16R Relay Board

The DB-16R 16 channel relay output board consists of 16 Form C relays for efficient switch of load by programmed control. It is connector and functionally compatible with 785 series board but with industrial type terminal block. The relay are energized by apply 5 voltage signal to the appropriated relay channel on the 20-pin flat connector 16 enunciator LED's, One for each relay, light when their associated relay is activated . To avoid overloading your PC's power supply, this board provides a screw terminal for power supply.

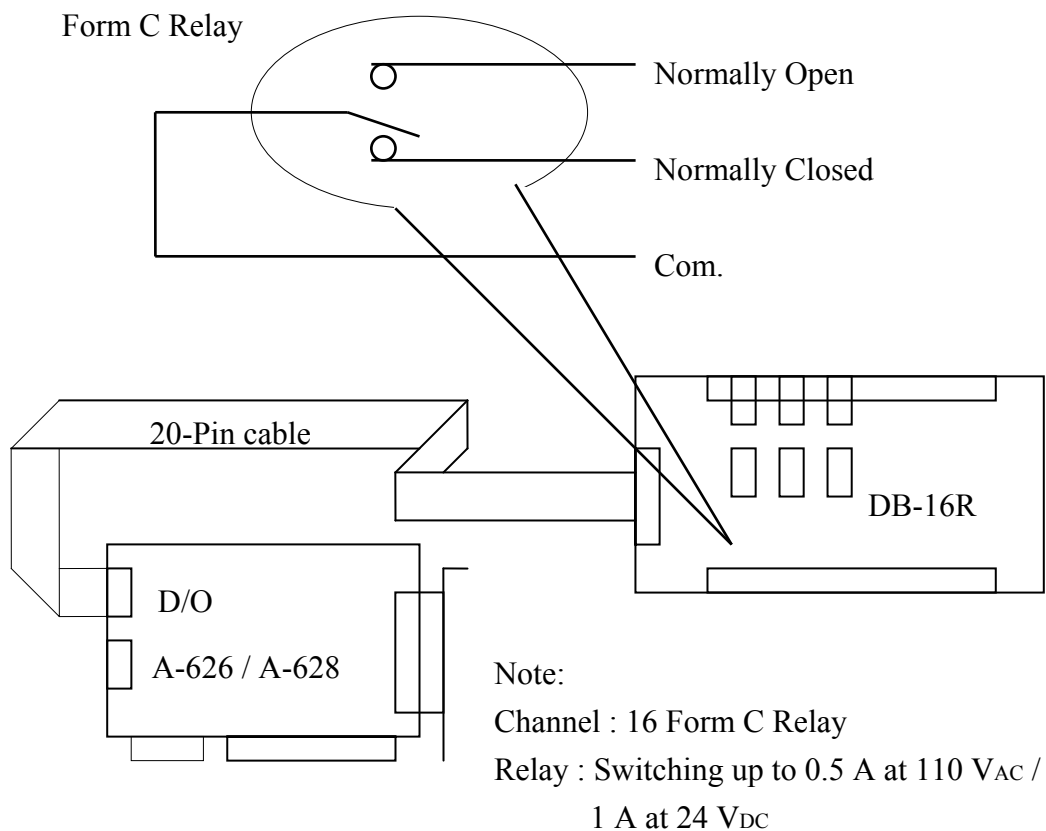

---

## 5.3. DB-24PR Power Relay Board

The DB-24PR 24-Channel Power relay output board consists of 8 Form C and 16 form A electromechanical relays for efficient switching of load programmed control. The contact of each relay can control a 5 A load at 250 V<sub>AC</sub>/30 V<sub>DC</sub>. The relay is energized by applying a 5 voltage signal to the appropriate relay channel on the 20-pin flat cable connector (Just used 16 relays) or 50-pin flat cable connector.(OPTO-22 compatible , for DIO-24 series ) . Twenty - four enunciator LEDs, one for each relay, light when their associated relay is activated. To avoid overloading your PC's power supply, this board needs a +12 V<sub>DC</sub> or +24 V<sub>DC</sub> external power supply.

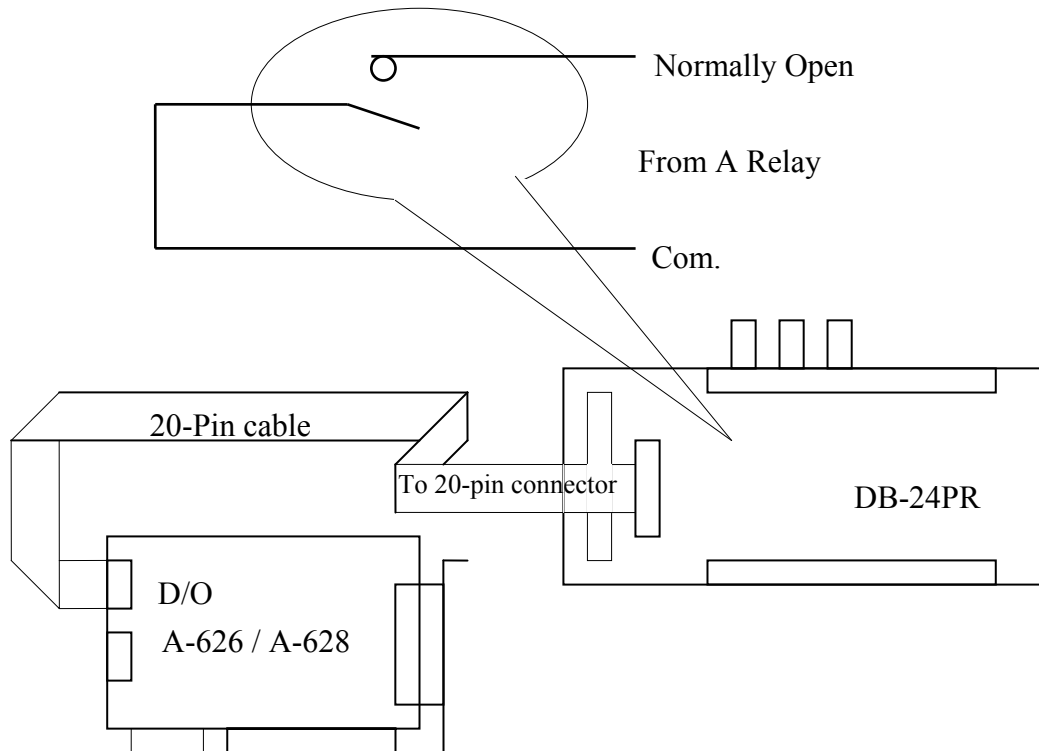

Note:

50-Pin connector (OPTO-22 Compatible) For DIO-24, DIO-48, DIO-144

20-Pin connector For 16 Channel digital output, A-82X, A-62X, DIO-64

Channel: 16 Form A Relay, 8 Form C Relay

Relay: Switching up to 5 A at 110 V<sub>AC</sub> / 5 A at 30 V<sub>DC</sub>

---

## 5.4. DB-8125 Screw Terminal Board

The DB-8125 is low cost universal screw terminal board for 37-pin D-type connector or two 20-pin connector.

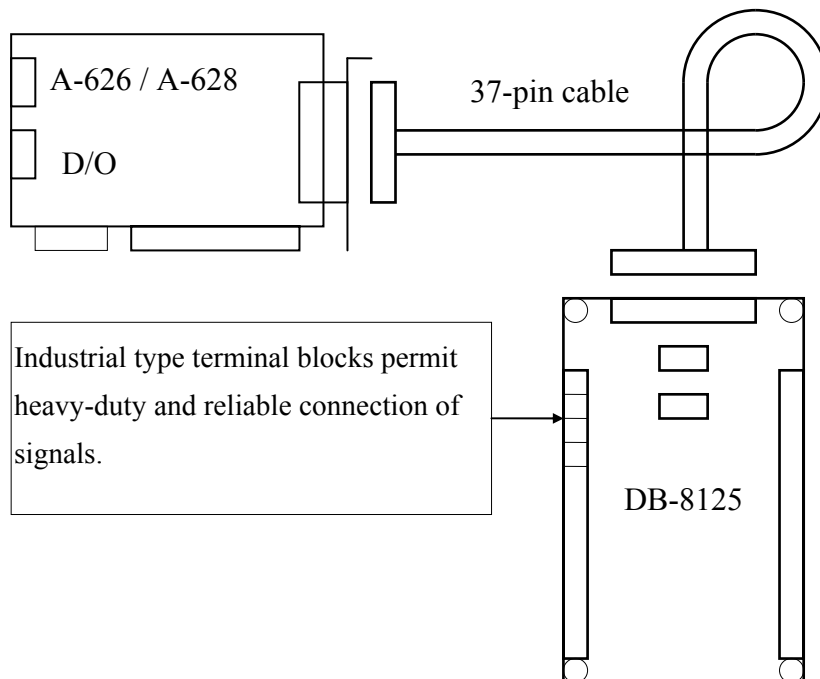

---

## 5.5. DN-37 (D-Sub I/O Connector Block with DIN Rail Mounting)

Termination accessory with 37 screw terminals for easy connection of field I/O signals to 37-pin boards. It includes one 37-pin D-sub connector for direct connection to 37-pin cables with hardware for mounting on a standard DIN rail.

