

ZB-2570/2571/2570P/2571P/2570-T/2571-T/2570P-T/2571P-T User Manual

Warranty

All products manufactured by ICP DAS are warranted against defective materials for a period of one year from the date of delivery to the original purchaser.

Warning

ICP DAS assumes no liability for damages consequent to the use of this product. ICP DAS reserves the right to change this manual at any time without notice. The information furnished by ICP DAS is believed to be accurate and reliable. However, no responsibility is assumed by ICP DAS for its use, or for any infringements of patents or other rights of third parties resulting from its use.

Copyright

Copyright 2009 by ICP DAS. All rights are reserved.

Trademark

The names used in this manual are for identification purposes only and may be registered trademarks of their respective companies.

Table of Contents

1.	<i>Introduction</i>	3
2.	<i>Specifications</i>	4
3.	<i>Product Description</i>	5
3.1	Internal I/O Structure	5
3.2	Appearance	7
3.3	Dimensions (Units: mm)	8
4.	<i>Applications</i>	9
4.1	Operating Modes	9
4.2	Application Example	11
5.	<i>Quick Start for the ZB-2570/2571/2570P/2571P/2570-T/2571-T/2570P-T/2571P-T</i> .	20
5.1	Installing the Configuration Tool	20
5.2	ZB-2570/2571/2570P/2571P/2570-T/2571-T/2570P-T/2571P-T_Configuration Hardware	22
5.3	Quick Start for the ZigBee Converter	24
5.4	Configure the Operating Mode	29
5.5	Installing the Hardware	45
6.	<i>Appendix</i>	48
7.	<i>Ordering Information</i>	52
8.	<i>Accessories</i>	53

1. Introduction

ZigBee Network

The ZB-2570/2570P is a host ZigBee converter, and the ZB-2571/2571P is a slave ZigBee converter. Each feature an Ethernet/RS-485/RS-232 interface. Devices that have an Ethernet/RS-485/RS-232 interface are also able to be connected using the ZB-2570/2570P/2571/2571P. By distributing host and slave ZigBee converters in the field, users can easily build a wireless network that can be used for both monitoring and control.

User-friendly interface

A Windows compatible GUI configuration utility is available. Only four steps are required in orders to set the ZB-2570/2571/2570P/2571P/2570-T/2571-T/2570P-T/2571P-T and then it is ready for use. The utility allows users to set different operating modes based on the type of application, together with several of the required ZigBee variables such as PAN ID, etc.

What are the benefits of using ZigBee?

ZigBee is a specification based on the IEEE 802.15.4 standard for wireless personal area networks (WPANs). It is targeted at applications that require secure networking, as well as high flexibility for network expansion anytime new nodes are to be added. It is also widely used in the industrial control field, in hospitals, labs and in building automation. Three topologies are defined in the IEEE 802.15.4 standard: Star, Cluster Tree and Mesh. The typical transmission range for the 2570/2571 is 100 m, and 700 m for the 2570P/2571P.

At present, ICP DAS ZigBee converter products support RS-232, RS-485 and Ethernet interfaces. The main design goal is aimed at limited data communication using wireless transmission, so may provide a better solution for environments where wiring is difficult. The ZigBee converter module provides six operating modes (Refer to [Section 4.2](#) for details). The ZB-2570/2571/2570P/2571P/2570-T/2571-T/2570P-T/2571P-T includes a repeater module (ZB-2510/2510P) that can be used to increase communication range or prevent data loss if the connection is interrupted or becomes unstable.

2. Specifications

Features:

- ISM 2.4 GHz operating frequency.
- Full compliance with 2.4 G IEEE 802.15.4/ZigBee specifications.
- Wireless transmission range up to 100 m (LOS) (ZB-2570/2571)
- Wireless transmission range is typical for 700 meters, up to 1 km (LOS) (ZB-2570P/2571P)
- GUI configuration software (Windows version)
- DIN-rail mountable.

Specifications:

Modules	ZB-2570	ZB-2570P	ZB-2571	ZB-2571P
Wireless				
RF Channels	16			
Receive Sensitivity	-102 dBm			
Transmit Power	12 dBm	18 ~ 24 dBm, adjustable	12 dBm	18 ~ 24 dBm, adjustable
Network Topology	Star, Mesh and Cluster tree			
Certification	TUV (ZCP)			
Antenna (2.4 GHz)	3 dBi Omni-directional antenna	5 dBi Omni-directional antenna	3 dBi Omni-directional antenna	5 dBi Omni-directional antenna
Transmission Range	100 m (LOS)	Typical for 700 meters up to 1 km (LOS)	100 m (LOS)	Typical for 700 meters up to 1 km (LOS)
General				
CPU	80186, 80 MHz or compatible			
Module Type	Host		Slave	
Communication Interface				
COM0	RS-232 (TxD, RxD, and GND); D-Sub 9 Female, Non-isolated		RS-232 (TxD, RxD, and GND); D-Sub 9 Male, Non-isolated	
Ethernet	10/100 Base-TX (Auto-negotiating, auto_MDI/MDI-X, LED indicators)			
COM0 Settings				
Baud Rate	1200 ~ 115200 bps			
Data Bit	7, 8			
Parity Check	Even, Odd, None			
Stop Bit	1			
LED Indicators				
ZigBee Net State	Green			
ZigBee RxD	Yellow			
Power	Red			
Power				
Protection	Power reverse polarity protection			
EMS Protection	ESD, Surge, EFT			
Required Supply Voltage	+10 V _{DC} ~ +30 V _{DC}			
Power Consumption	2.5 W	4 W (max.)	2.5 W	4 W (max.)
Connection	5-pin 5.08 mm Removable Terminal Block			
Mechanical				
Casing	Plastic			
Flammability	UL 94V-0 materials			
Dimensions (W × L × H)	33 mm × 78 mm × 107 mm			
Installation	DIN-rail			
Environment				
Operating Temperature	-25 °C ~ +75 °C			
Storage Temperature	-40 °C ~ +80 °C			
Relative Humidity	5 ~ 95% RH, non-condensing			

3. Product Description

3.1 Internal I/O Structure

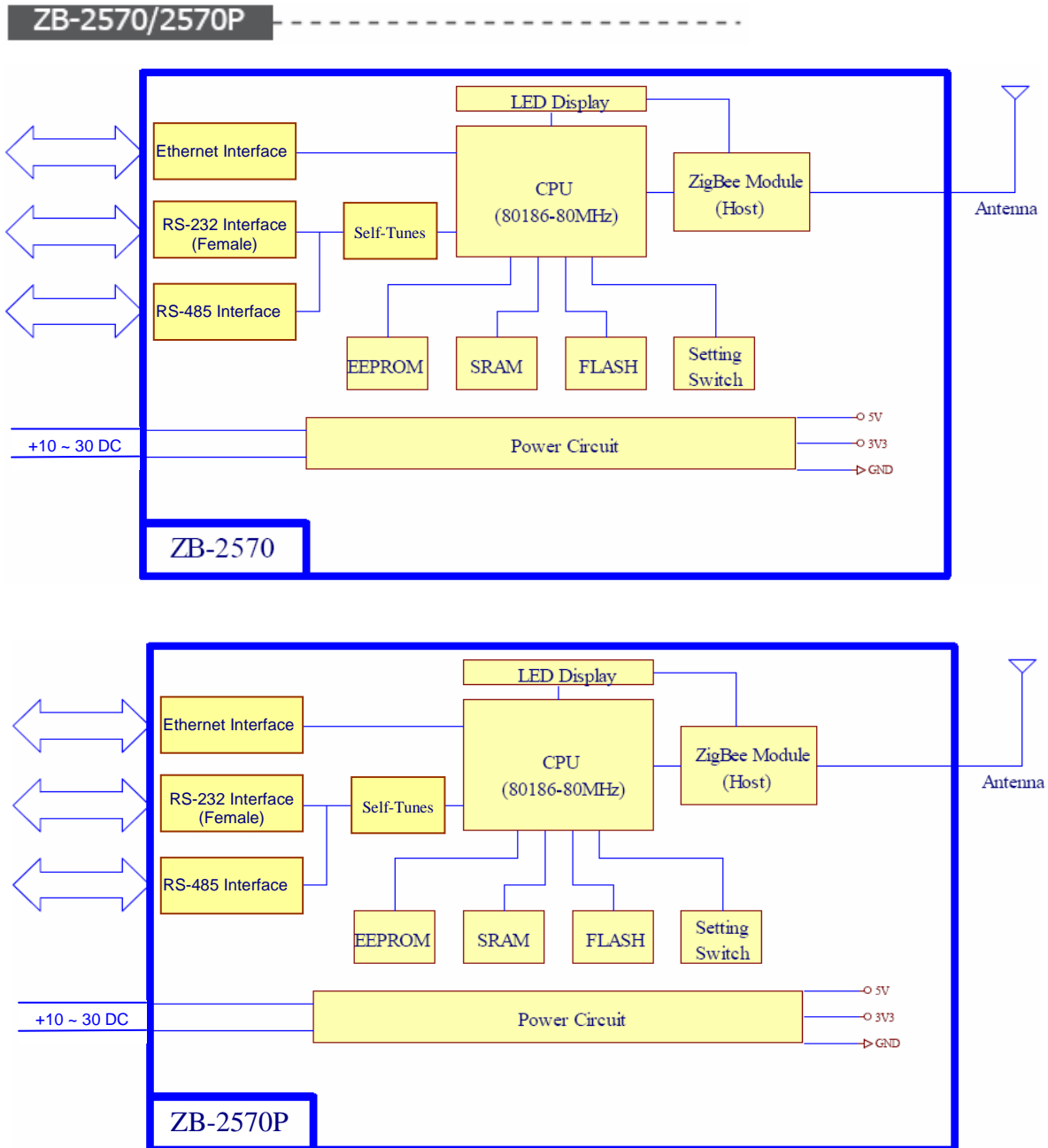

ZB-2571/2571P

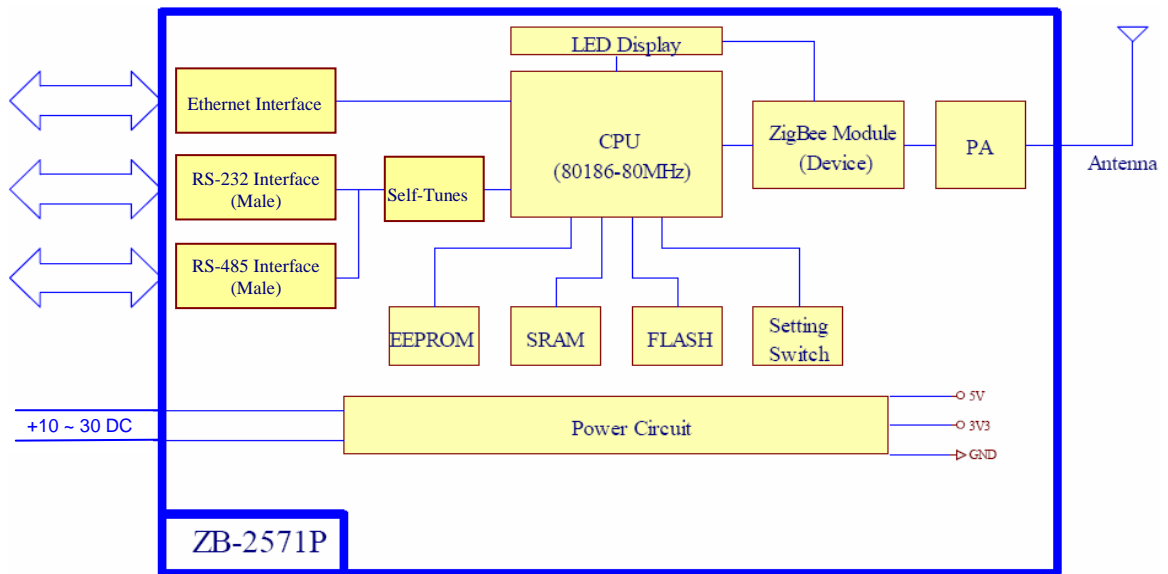
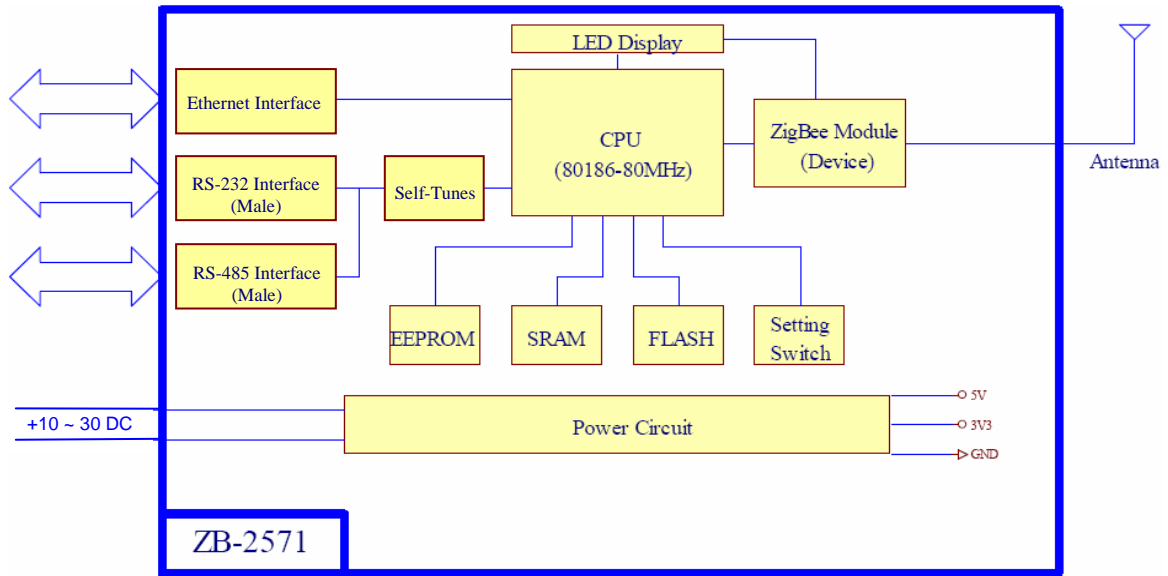

3.2 Appearance

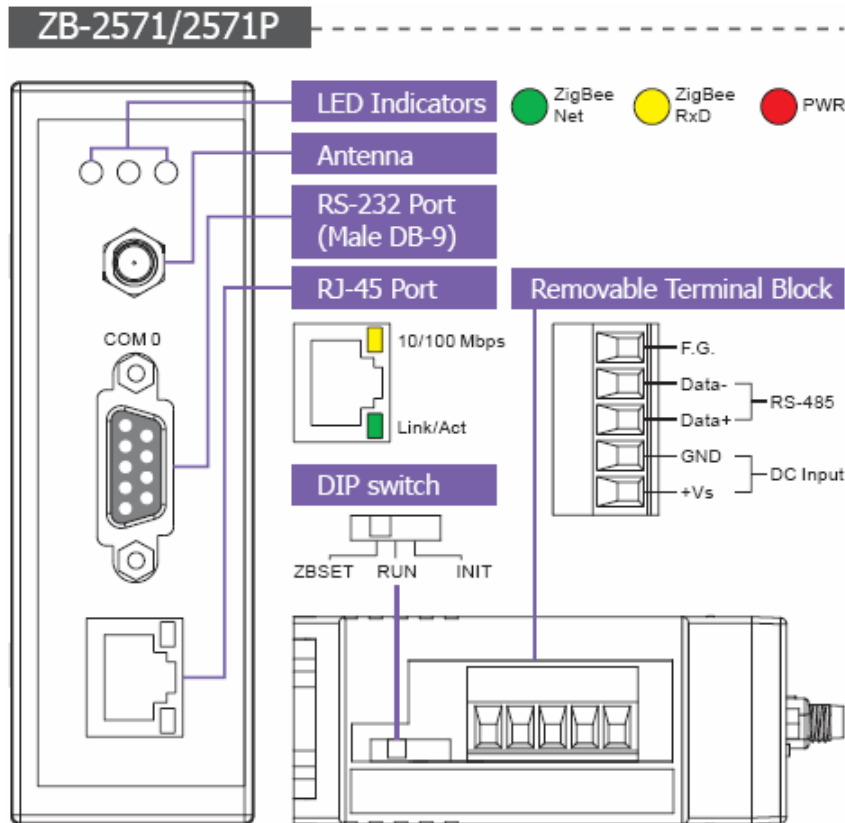
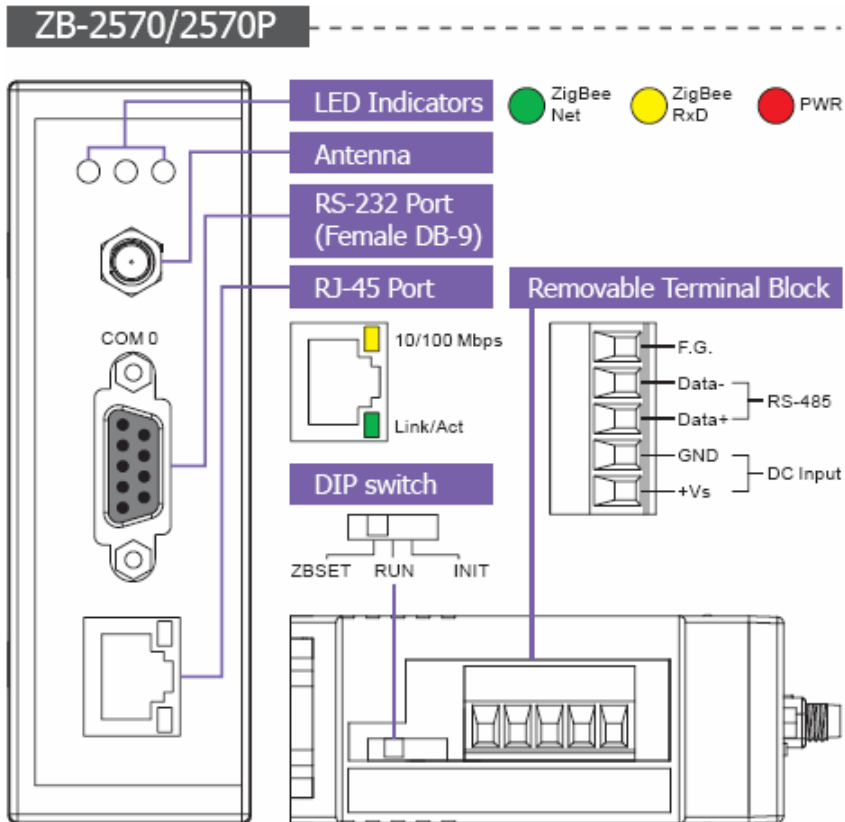

3.3 Dimensions (Units: mm)

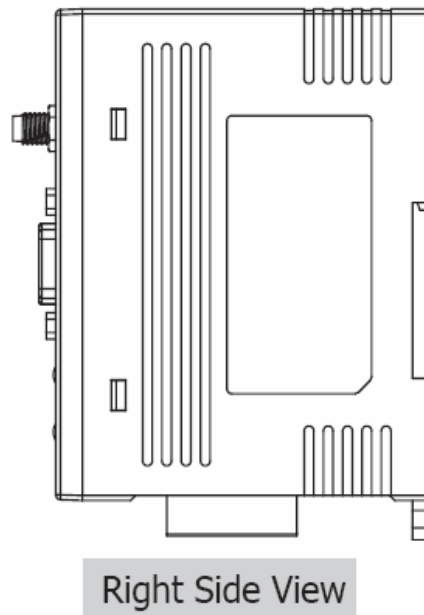
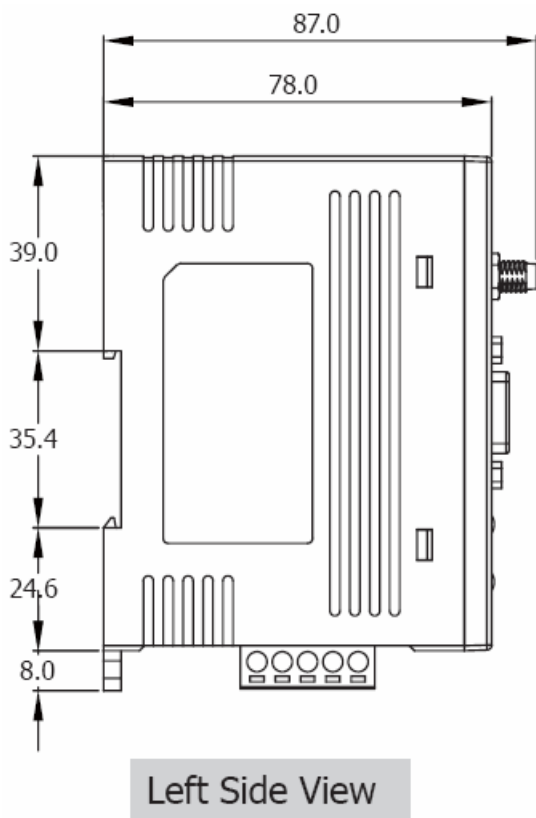
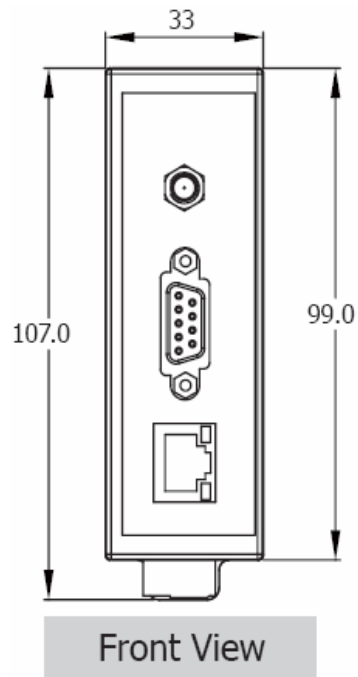
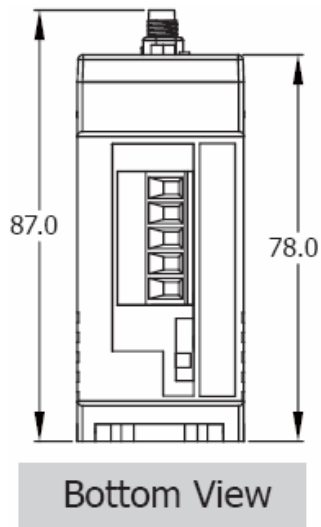

4. Applications

4.1 Operating Modes

Interface	Operating Mode	ZB-2570/2570P	ZB-2571/2571P
Serial Port (RS-232/RS-485)	Transparent non-addressable	Transparent non-addressable	Transparent non-addressable
	Modbus RTU/ASCII	Modbus RTU/ASCII	Modbus RTU/ASCII
	Transparent addressable	Transparent addressable	Transparent addressable

Interface	Operating Modes	ZB-2570/2570P	ZB-2571/2571P
Ethernet (RJ-45)	Transparent non-addressable	TCP (Server/Client)	TCP (Server/Client)
	Modbus TCP	Modbus TCP (Server/Client)	Modbus TCP (Server/Client)
	Transparent addressable	TCP (Server/Client)	TCP (Server/Client)

Interface	Operating Mode	ZB-2570/2570P	ZB-2571/2571P
Serial Port (RS-232/RS-485) & Ethernet (RJ-45)	Modbus RTU/ASCII to Modbus TCP	Modbus RTU/ASCII	Modbus TCP (Server/Client)
		Modbus RTU/ASCII	
	Modbus TCP to Modbus RTU/ASCII	Modbus TCP (Server/Client)	Modbus RTU/ASCII
			Modbus RTU/ASCII

Interface	Operating Modes	ZB-2570/2570P	ZB-2571/2571P
Ethernet (RJ-45) & Serial Port (RS-232/RS-485)	Virtual COM to Transparent	Virtual COM	Transparent Mode

◆ [Refer to Chapter 5 for further details regarding setting arguments.](#)

4.2 Application Example

1. Serial Transparent Non-addressable Mode:

When the ZB-2570/2570P (host) receives data via either the RS-232 or RS-485 port, it broadcasts it to the ZigBee mesh. When the ZB-2571/2571P (slave) receives the packet, the ZB-2571/2571P sends it to the remote I/O module via the RS-485 port. The remote device responds to the PC or controller via the same path. If your device is addressable, such as the ICP DAS I-7000/M-7000/I-87k remote I/O modules, this mode can be used to control the remote device.

In this mode, any data that is more than 50 bytes of data, will be divided into individual packets of 50 bytes. Each the ZigBee module will then for wait 50 ms after sending a packet. When the ZB-2571/2571P receives a packet, it will immediately pass the data to the remote device. The remote device transmits data in the same way.

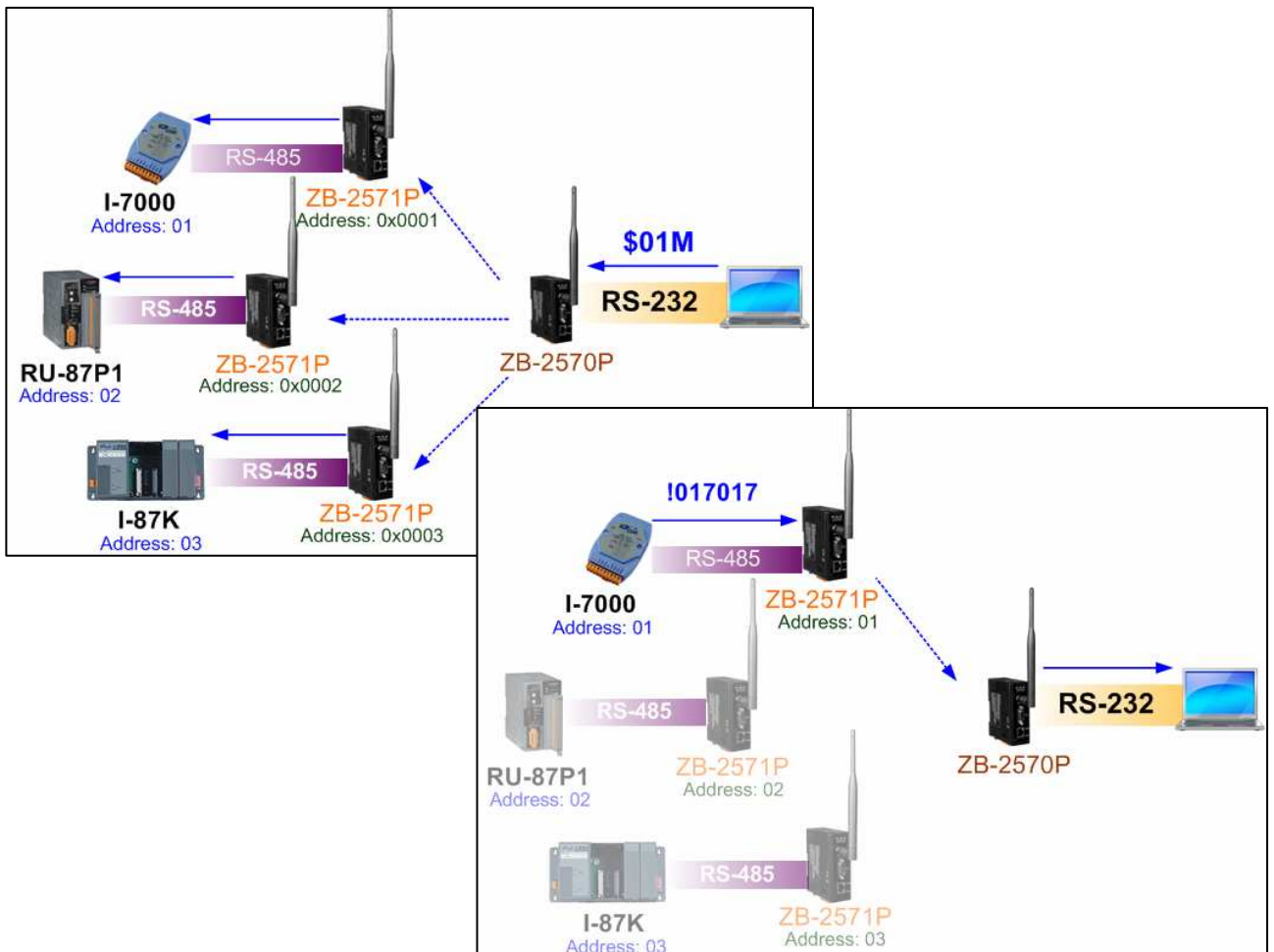

This mode can also be used in applications where the host controller needs to broadcast data to all RS-232/RS-485 devices and the devices only receive data (i.e. there will be no response).

2. Modbus RTU/ASCII Mode:

This mode is used for Modbus RTU/ASCII devices. The PC or controller can be connected to the ZB-2570/2570P using either the RS-232 or RS-485 interface and the device can be connected to the ZB-2571/2571P using the RS-485 interface. In this mode, any data that is more than 50 bytes will be divided into packets of 50 bytes. The ZigBee module will wait for 50 ms after sending a packet. When the ZB-2571/2571P has received all packets, it will pass the data to the remote device. The remote device transmits data in the same way.

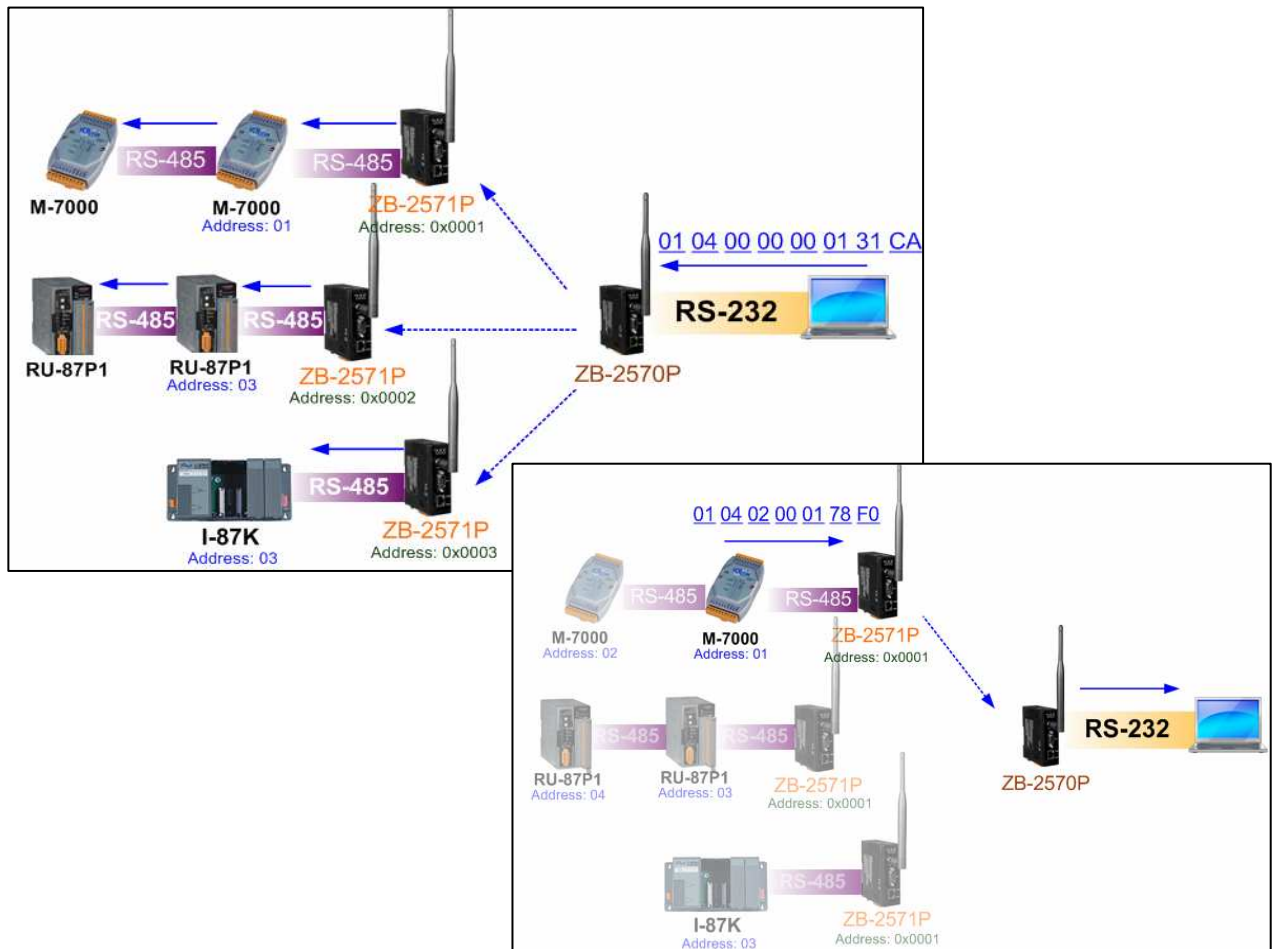

3. Serial Transparent Addressable Mode:

If the RS-232/RS-485 interface modules aren't addressable, this mode can be used to set an address for the ZB-2571/2571P ranging from 1~0xFFFF (the ZB-2570/2570P is always set as 0). By adding 5 ASCII characters to the header of the original request data from the controller, the remote device with the assigned address will respond to it. This mode is similar to that used in ICP DAS I-752N products.

The transmission delay in this mode is the same as that of Serial Transparent Non-addressable Mode.

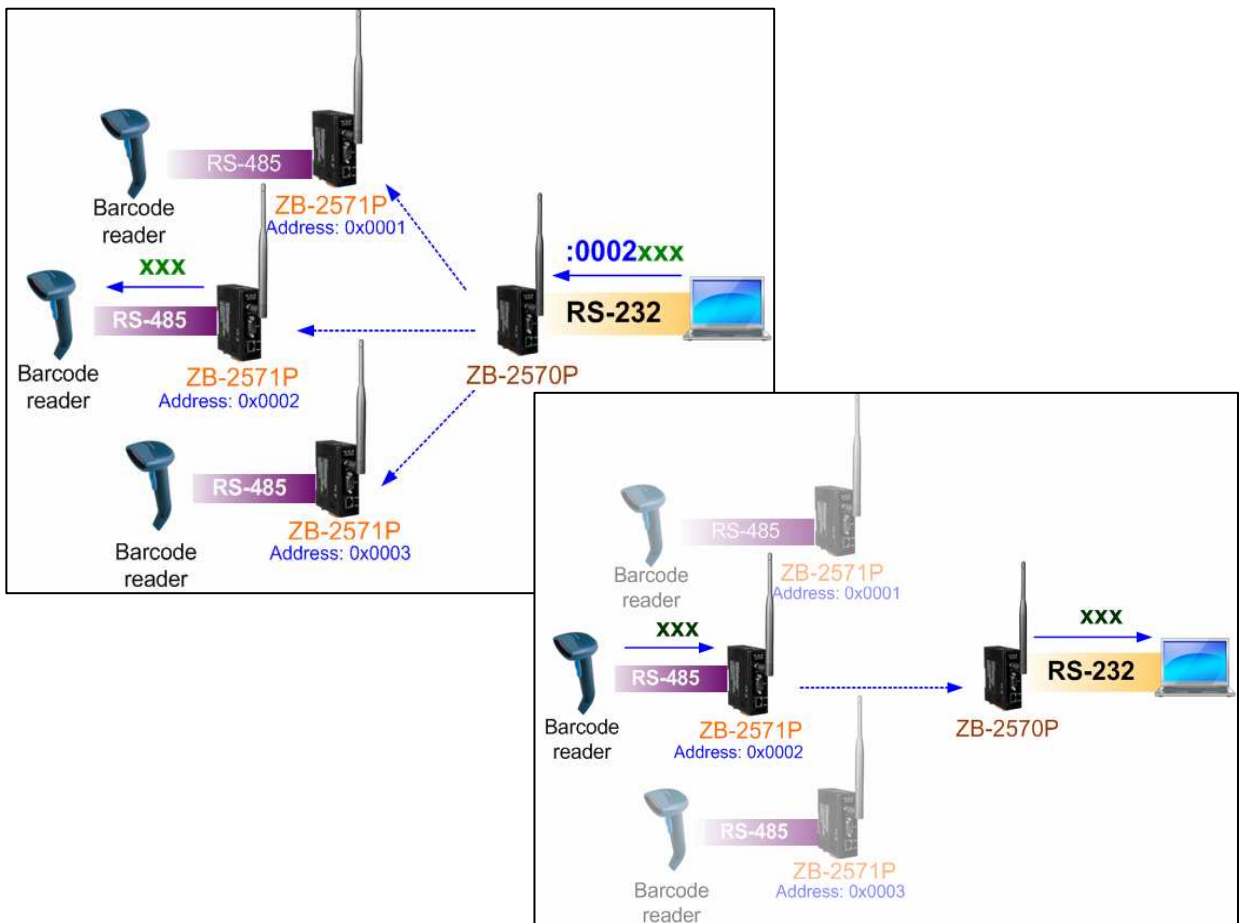

4. Ethernet Transparent Non-addressable Mode :

This mode is similar to Serial Transparent Non-addressable mode, but is used to connect to Ethernet devices. A socket should be created using the ZB-2570/2570P or controller instead of using a remote device on the controller side. The ZB-2571/2571P or end device will create a socket connection between each device (the connection IP and port number should be set via the ICP DAS utility software before use.). When the controller sends a TCP package to the ZB-2570/2570P module, the module will broadcast it. When the ZB-2571/2571P module receives the data from the ZB-2570/2570P, it will forward it to the end device. If the device responds to the data, the ZB-2571/2571P will only send the TCP package to the ZB-2570/2570P. The controller will then receive the data that is forwarded from the ZB-2570/2570P.

The transmission delay in this mode is the same as that of Serial Transparent Non-addressable Mode.

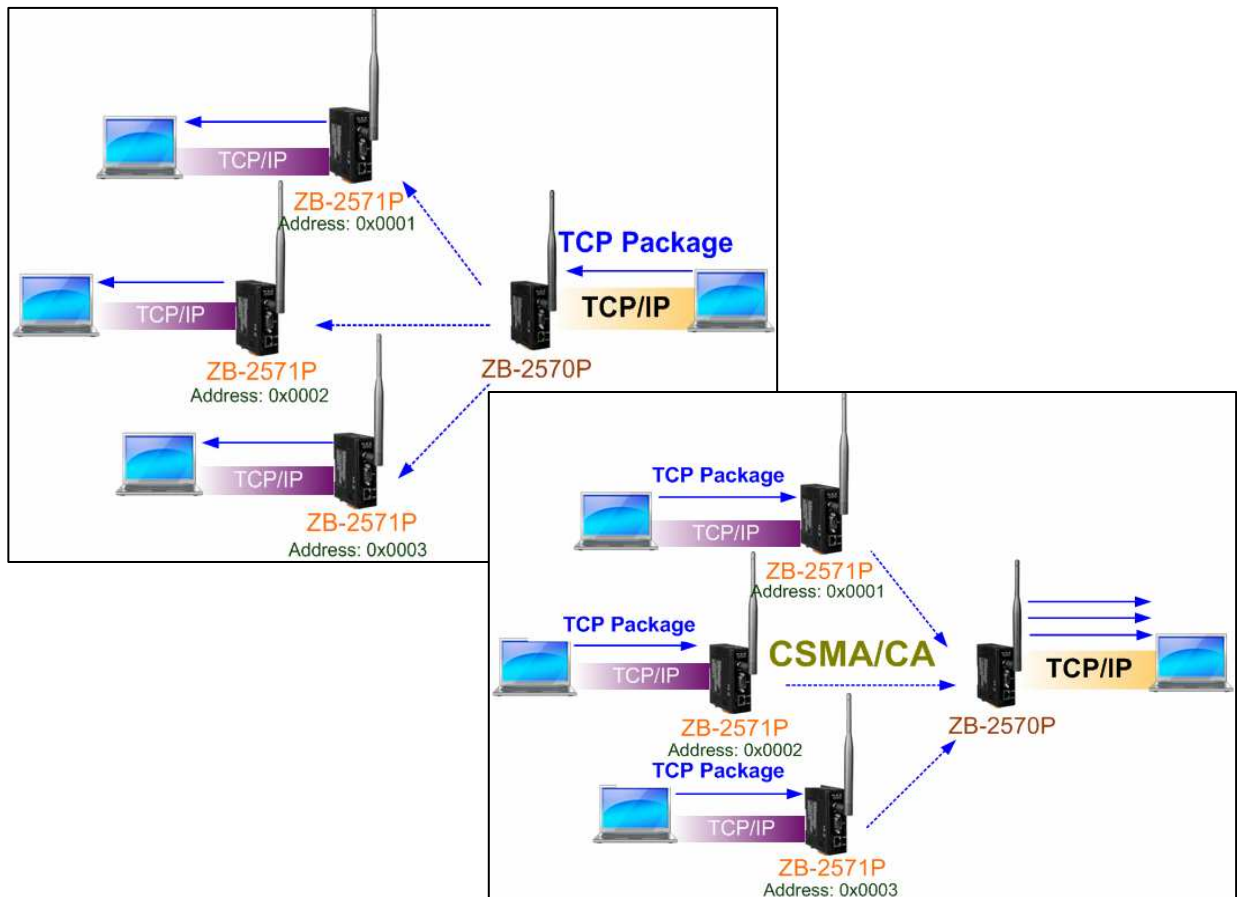

5. Modbus TCP Mode:

This is a specific mode for Modbus TCP devices. A mapping address to the Modbus TCP device in the ZB-2571/2571P should first be set using the ICP DAS utility software, then any Modbus TCP request commands can be sent from your SCADA software or your own software via the ZB-2570/2570P module. The device with the assigned address will then respond to the command.

For example, if the default address of your Modbus TCP device is 1 and you set the mapping address of the ZB-2571/2571P to address 2, you should send a Modbus TCP request command from your software with the address field set as 02.

The transmission delay in this mode is the same as that of Modbus RTU/ASCII Mode.

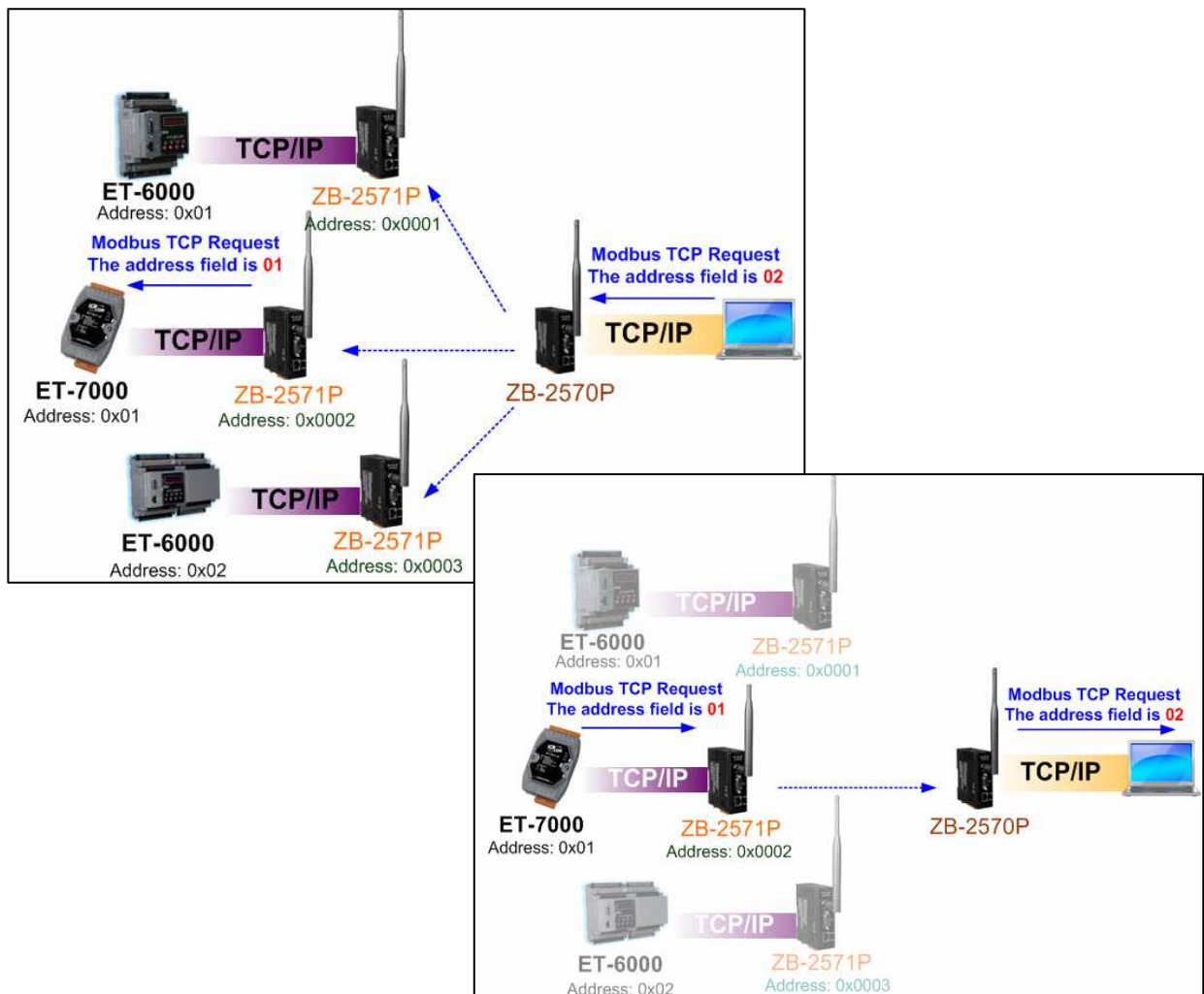

6. Ethernet Transparent Addressable Mode :

This mode is similar to Serial Transparent addressable, but is used to connect to Ethernet devices.

The transmission delay in this mode is the same as that of Serial Transparent Non-addressable Mode.

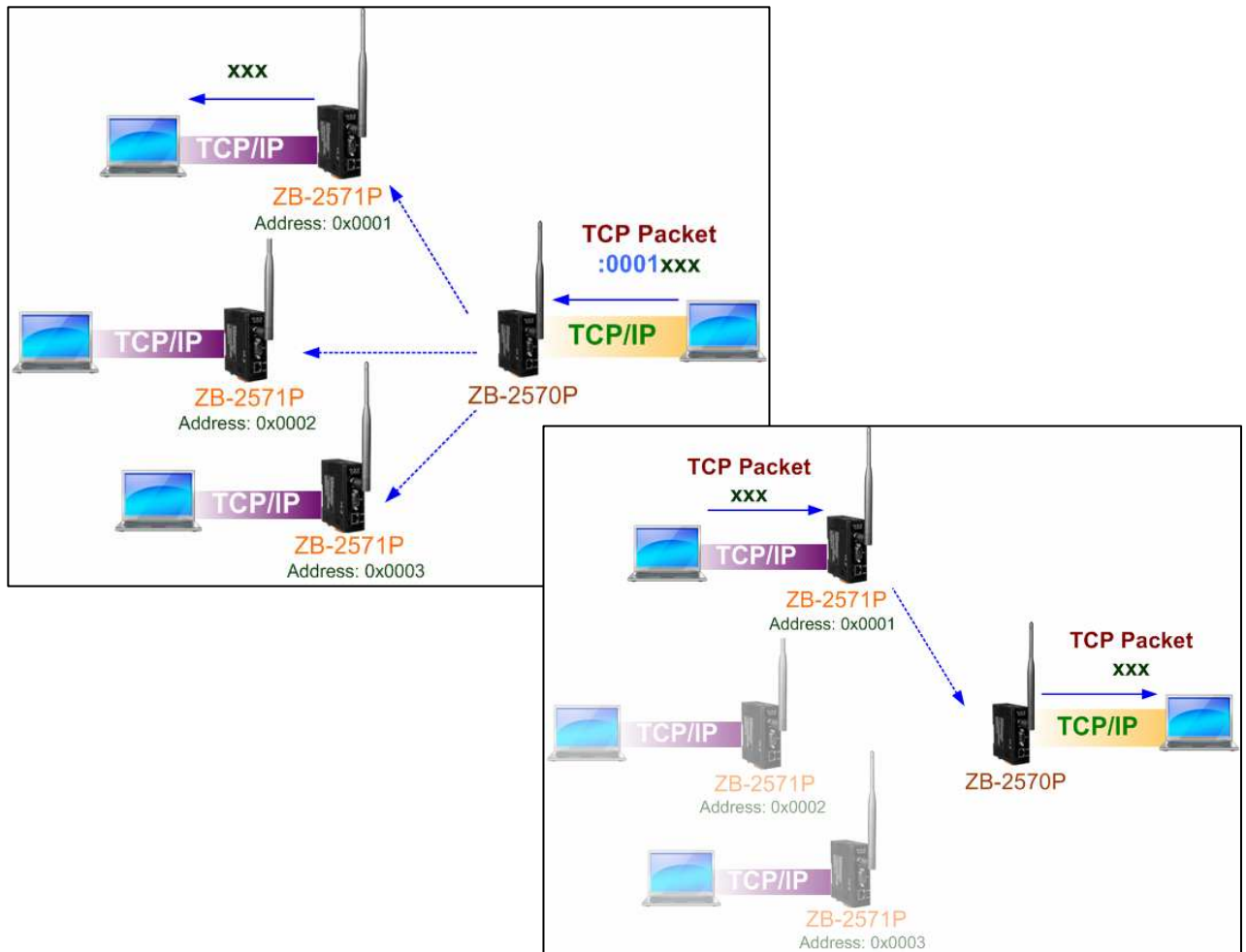

7. Modbus RTU/ASCII to Modbus TCP Mode:

This is a specific mode for Modbus RTU/ASCII devices in the controller side and Modbus TCP devices on the remote side. A mapping address to the Modbus TCP device in the ZB-2571/2571P should first be set using the ICP DAS utility software, then Modbus TCP request commands can be sent from your SCADA software or your own software via the ZB-2570/2570P module. When ZB-2570/2570P receives a command from the controller, the ZB-2570/2570P will broadcast it. The ZB-2571/2571P module with the assigned address will transform the address into the mapping address and change the protocol from Modbus RTU/ASCII mode to Modbus TCP mode. When end device receives the command from the ZB-2571/2571P module, it will respond using the Modbus TCP protocol. The ZB-2571/2571P module will transform the mapping address into the address, change the protocol from Modbus TCP mode to Modbus RTU/ASCII mode and send the command to ZB-2570/2570P module. When the ZB-2570/2570P receives the data, it will send it to the controller.

The transmission delay in this mode is the same as that of Modbus RTU/ASCII Mode.

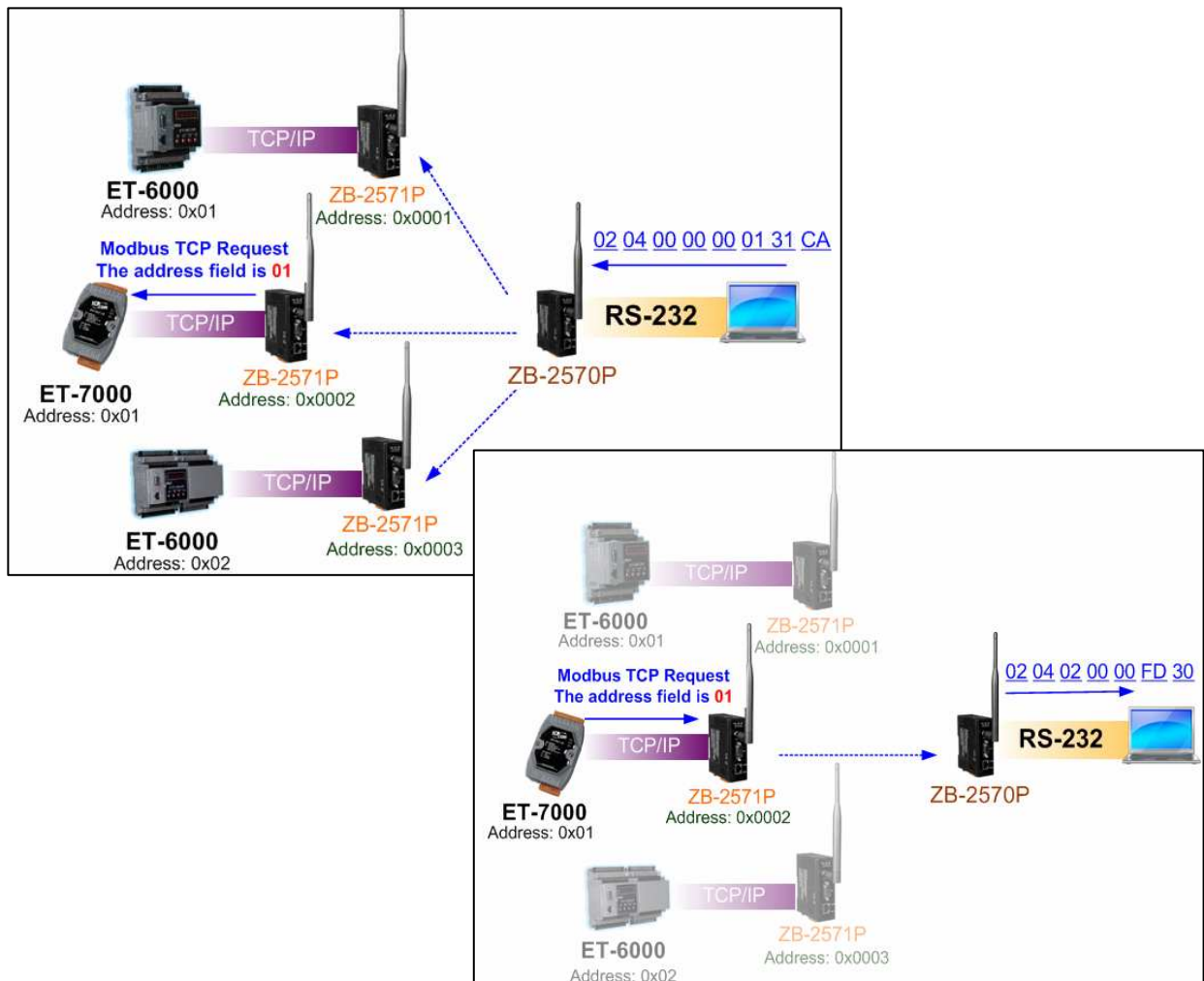

8. Modbus TCP to Modbus RTU/ASCII Mode:

This is a specific mode for Modbus TCP devices on the controller side and Modbus RTU/ASCII devices on the remote side. When the ZB-2570/2570P module receives a command from the controller, it will change the protocol from Modbus TCP mode to Modbus RTU/ASCII mode and broadcast it and the end device with the assigned address will respond. When the ZB-2571/2571P module receives data from the end device, it will change the protocol from Modbus TCP mode to Modbus RTU/ASCII mode and send the command to the ZB-2570/2570P module. When the ZB-2570/2570P module receives the data, it will send the data to your controller.

The transmission delay in this mode is the same as that of Modbus RTU/ASCII Mode.

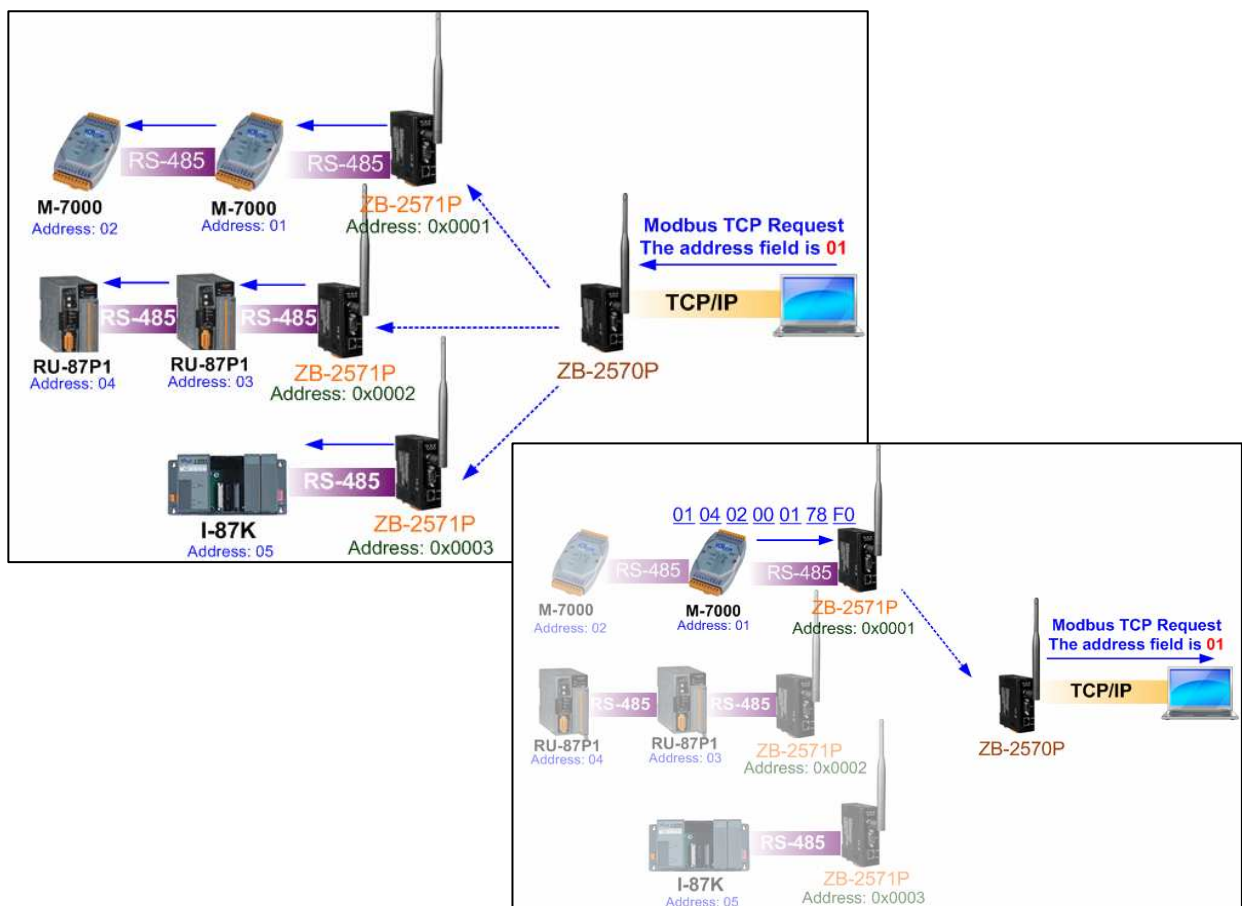

9. Virtual COM Transparent Mode:

This is a specific mode that allows TCP/IP to be used as simply as a serial port. Before using this mode, the Vxcomm utility must be installed and correctly configured. Once set up, open the Virtual Com Port and send a command to the physical Com Port. The data will be exported from COM1 of the ZB-2571/2571P module. When the module receives data from COM1, it will be exported from the Virtual Com Port.

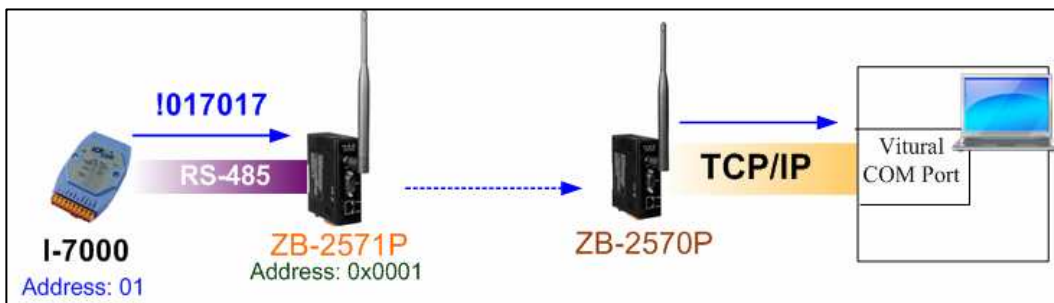
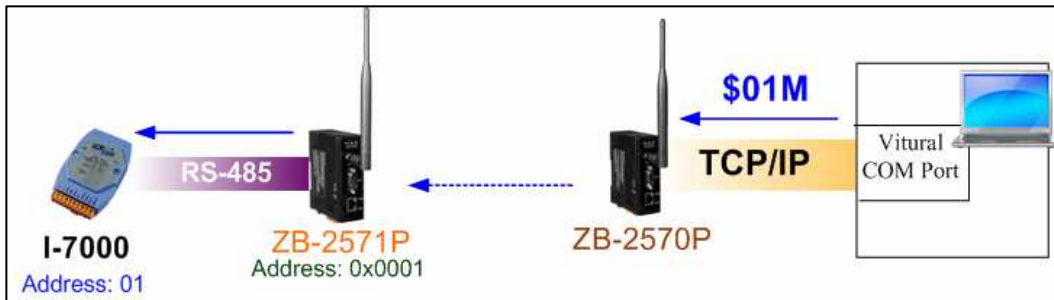

5. Quick Start for the

ZB-2570/2571/2570P/2571P/2570-T/2571-T/2570P-T/2571P-T

5.1 Installing the Configuration Tool

1. Download the file from:

http://ftp.icpdas.com/pub/cd/usbcd/napdos/zigbee/zigbee_converter/zb_257x/utility/

2. Uncompress the file and double click the **setup_ver_3.6.exe** file to install the configuration tool for the ZigBee converter.



3. When the following screen is displayed, click the **Next>** button to continue the installation, or click **Cancel** to exit the installation.

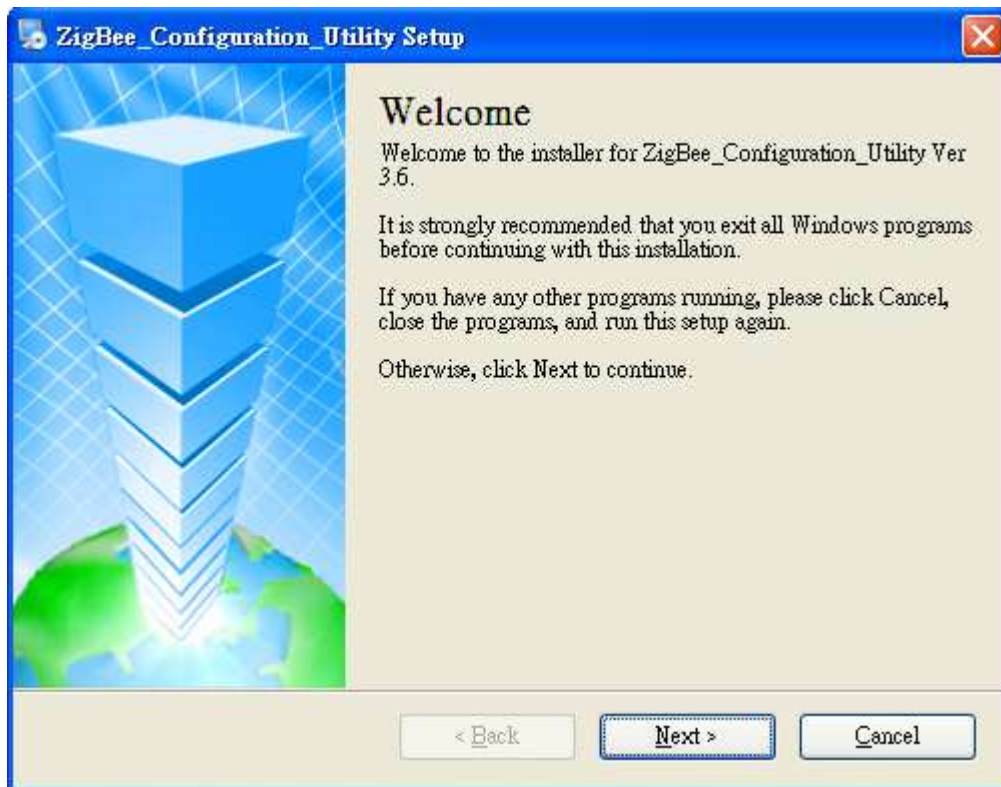

4. When the following screen is displayed, either click the **Next>** button to install the software into the default directory, or click the **Change...** button to install into an alternate location. Click the **Cancel** button to quit the installation.

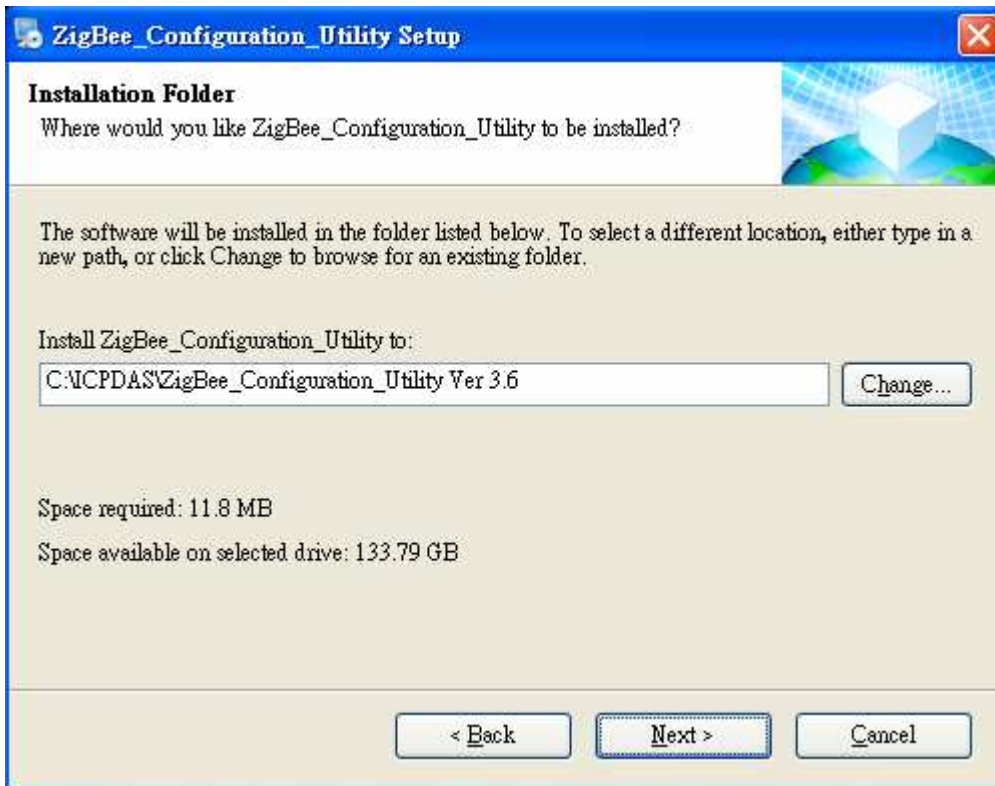

5. When the following screen is displayed, click the **Finish** button to finalize the software installation.

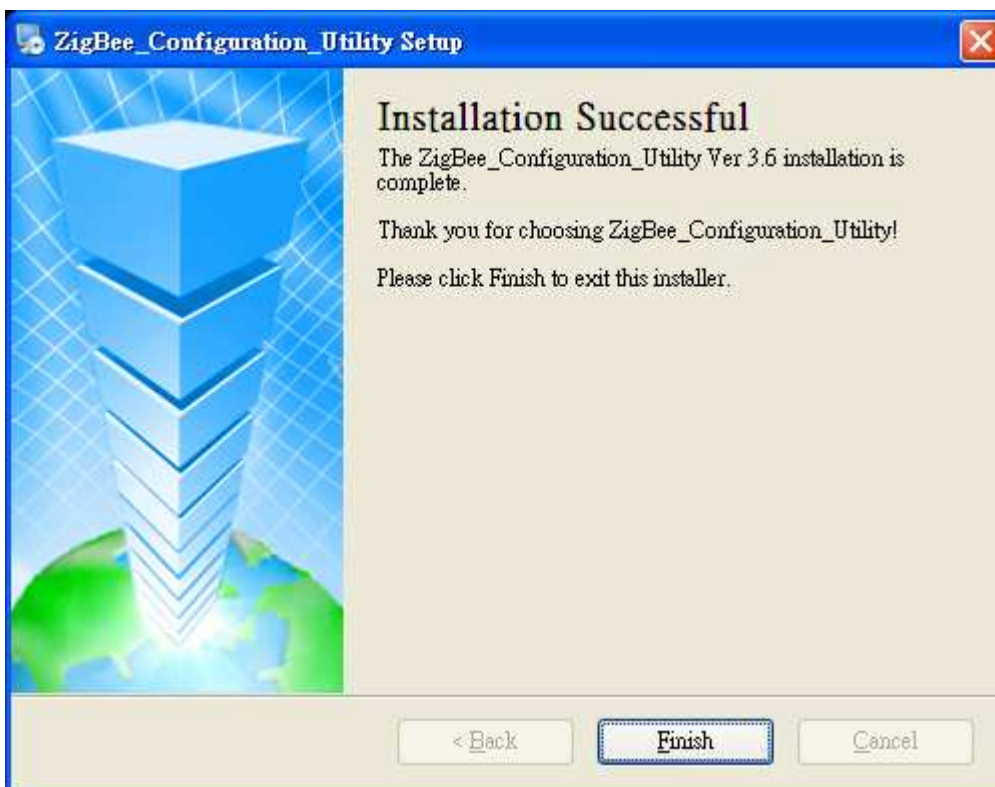

5.2 ZB-2570/2571/2570P/2571P/2570-T/2571-T/2570P-T/2571P-T

Configuration Hardware

- I. Adjust the switch to the **ZBSET** position then power on the module.

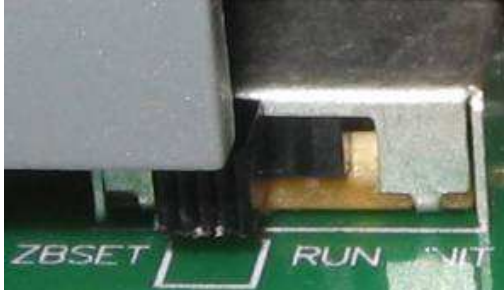

- II. Configure the serial port and ethernet hardware

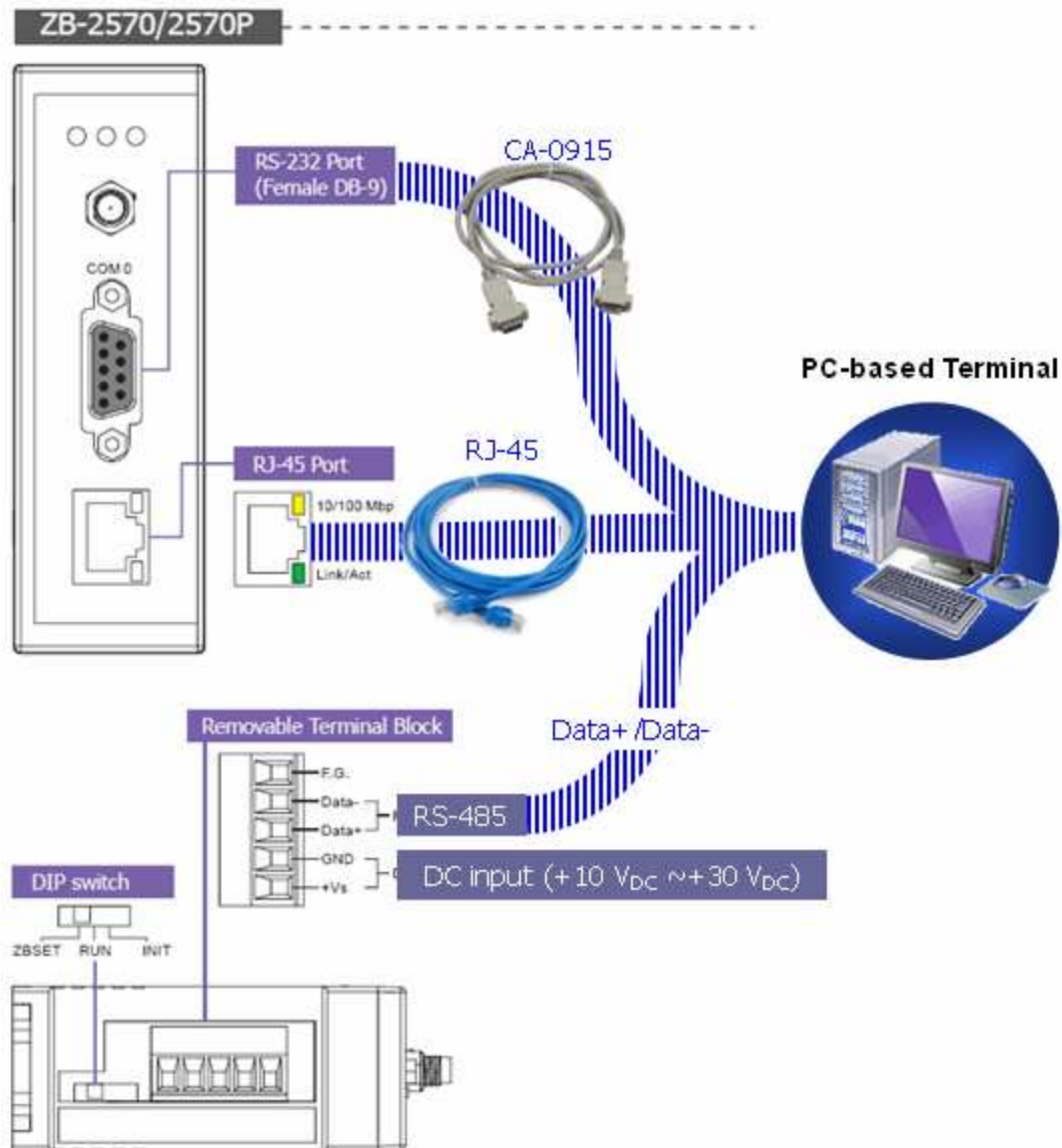

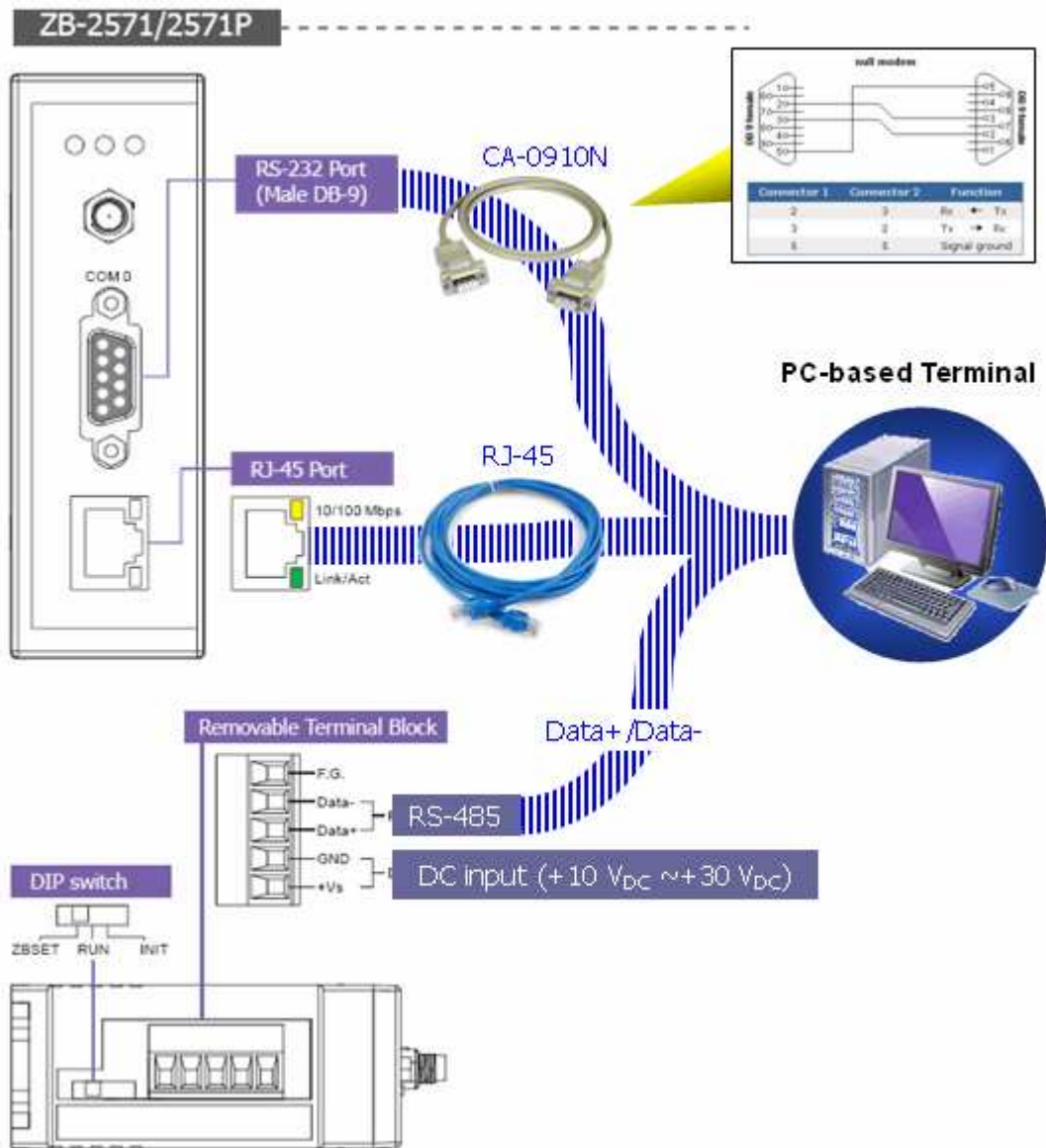

5.3 Quick Start for the ZigBee Converter

1. Before configuring the ZigBee converter, adjust the switch to the **ZBSET** position then switch on the power (**Figure 1**). After configuration is complete, power off the device, adjust the switch to the **RUN** position then switch the power on again (**Figure 2**). Be sure to turn the power off before adjusting the switch.



Figure 1



Figure 2

2. Install the ZigBee_Configuration_Utility_Ver_4.1.2,

The executable file can be found at:

C:\ICPDAS\ZigBee-257x_Configuration_Utility_Ver_4.1.2



3. Connect the ZigBee converter using one of the hardware interfaces (RS-232, RS-485 or Ethernet; the default configuration interface is RS-232) and execute the utility.

4. When the following screen is displayed:

In the *Environment Settings* section:

1. Choose the language.
2. Choose the module (ZB-2570/2571/2570P/2571P/2570-T/2571-T/2570P-T/2571P-T).
3. Click the **Next** button.

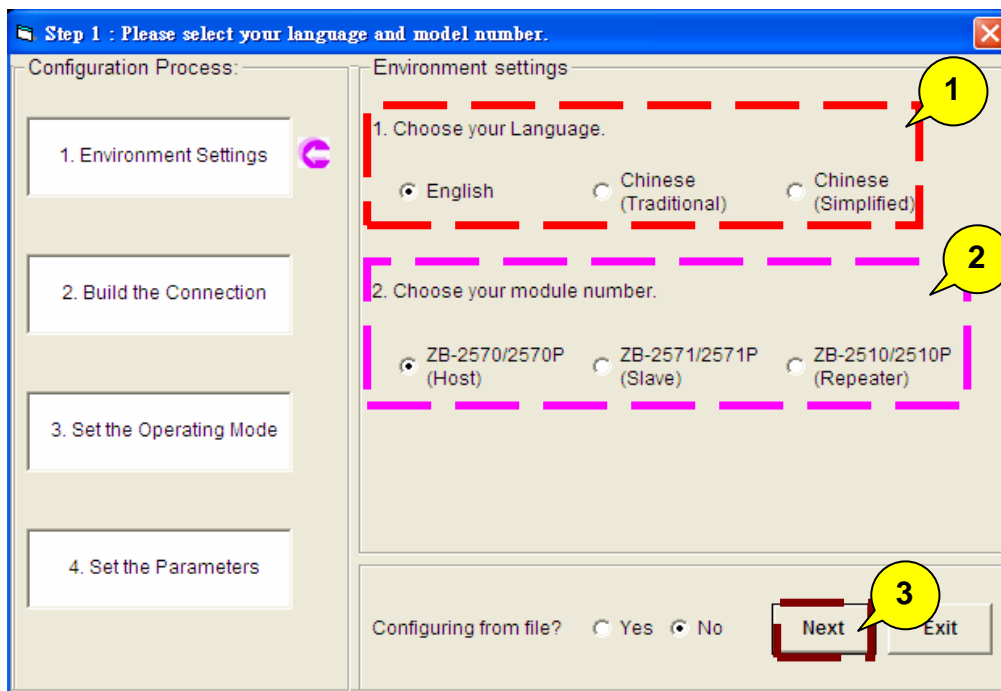

5. When the following screen is displayed:

In the *Build the Connection* section:

1. Select the configuration interface of your ZigBee converter module.

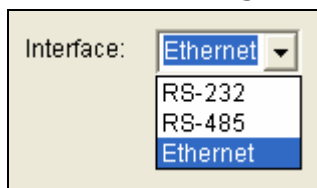

2. Enter the interface parameters (COM Port number or IP)

Ethernet Interface:

IP: 192 168 255 1

Serial Port Interface:

COM Port: COM1

3. Click the **Connect** button.

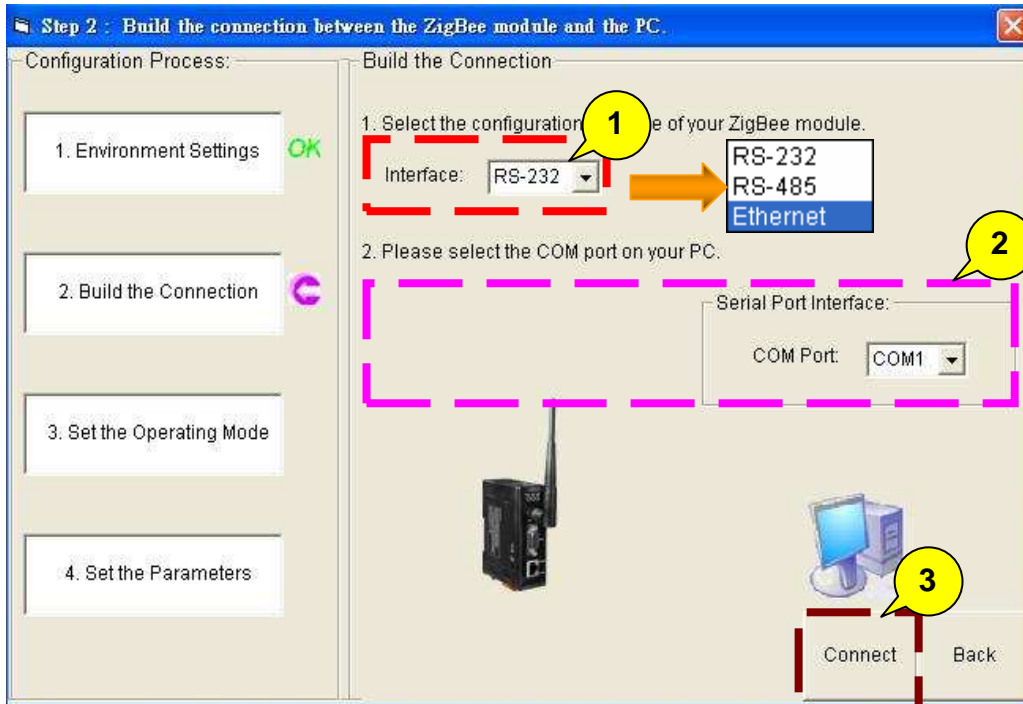

6. When the following screen is displayed:

In the *Set the Operating Mode* section:

1. Select the interface that you plan to use for your ZigBee converter and devices.

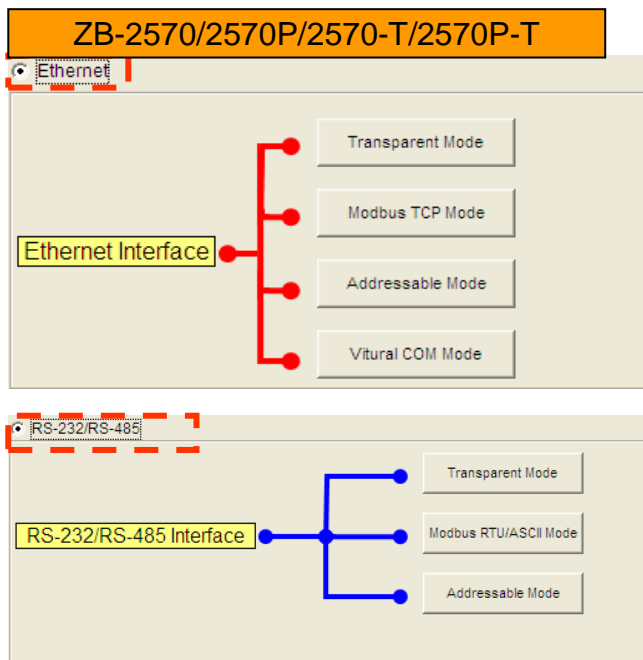

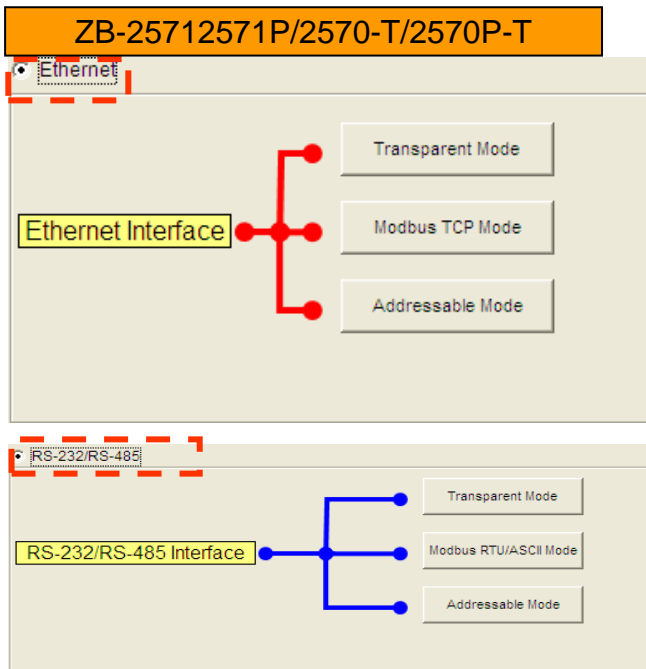

2. Select the operating mode that you plan to use for your ZigBee converter and devices.

If you select the Ethernet interface, you must also select the operation mode and assign the ZB-2570/2570P or ZB-2571/2571P as either server or a client device.

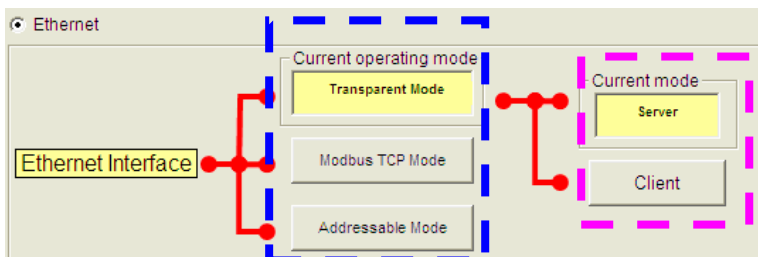

If you select the RS-232/RS-485 interface, only the operation mode needs to be selected.

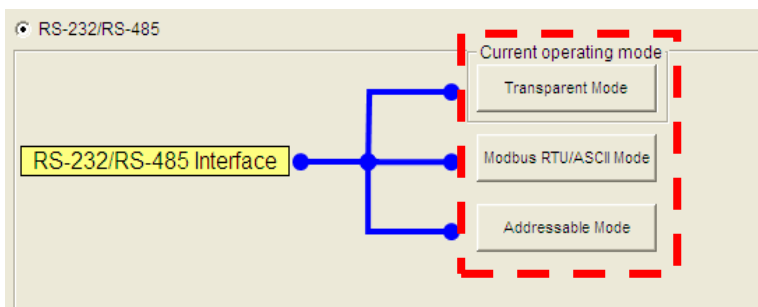

3. Click the **Set** button.

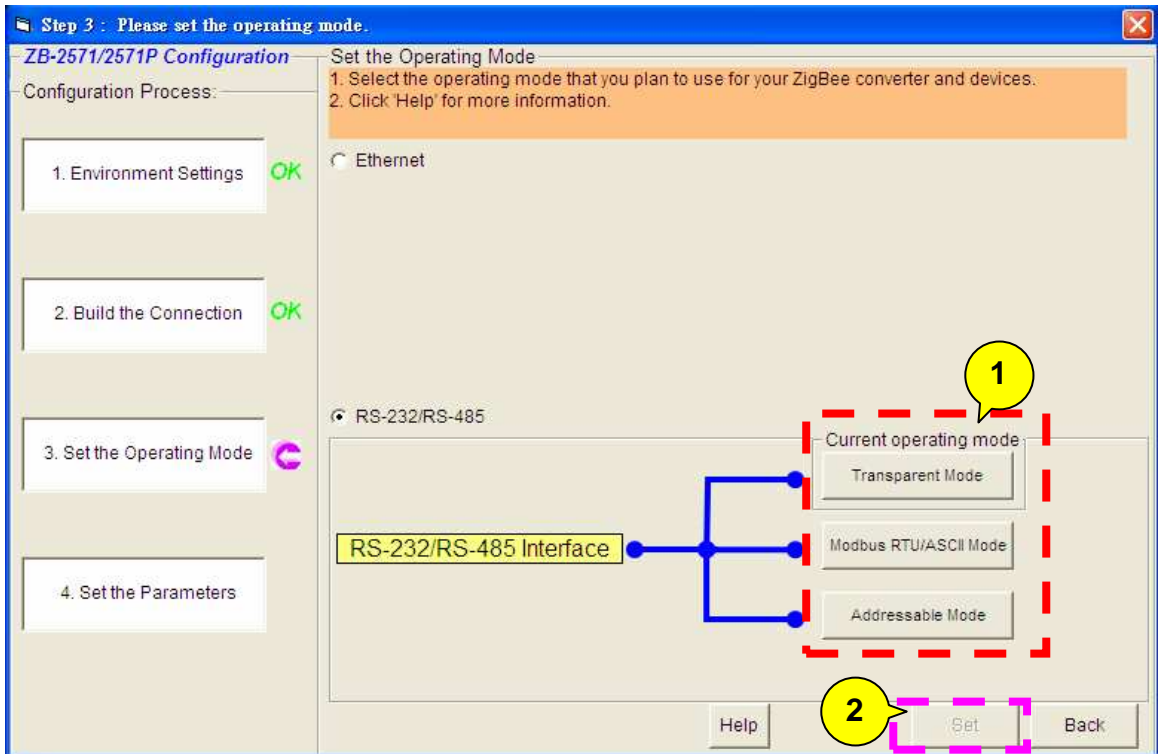

7. When the following screen is displayed:

In the *Set the Parameters* section:

1. Set the ZigBee parameters. After entering the ZigBee parameter settings, click the **Set** button.
2. Set the interface parameters, after finishing the interface parameter settings, click the **Set** button.
3. Click the **OK** button.

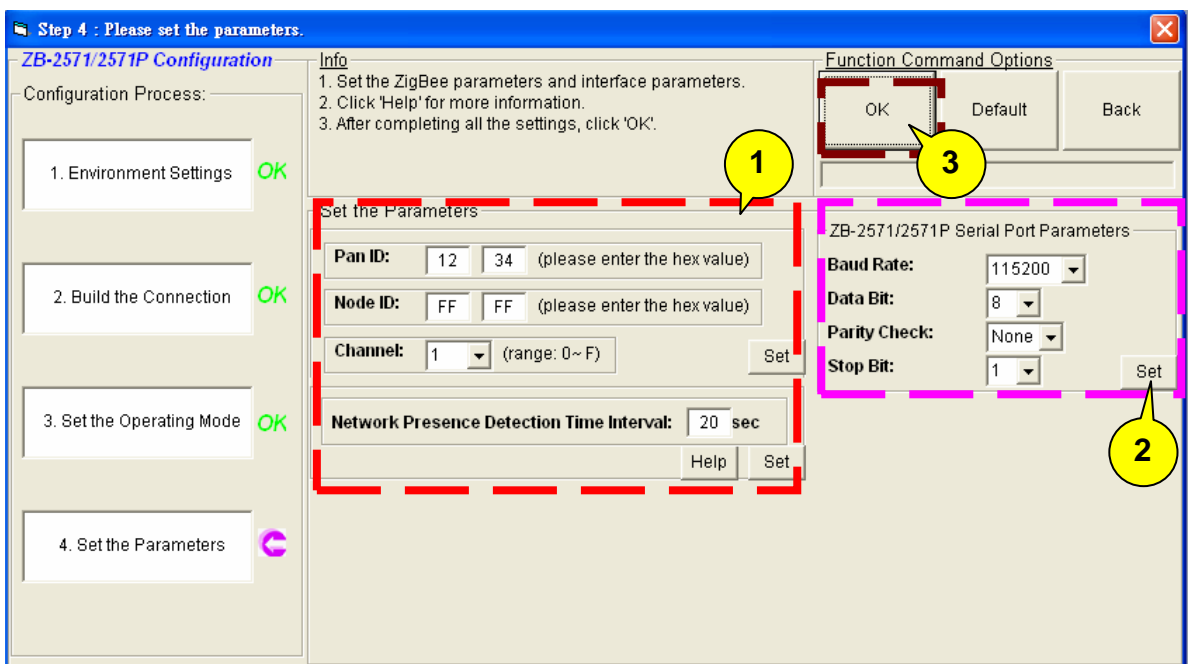

When the following alert is displayed, it means that the configuration has been successful. Click the **OK** button to continue the configuration.



When the following alert is displayed, it means that configuration is complete. Click the **OK** button to exit the configuration.

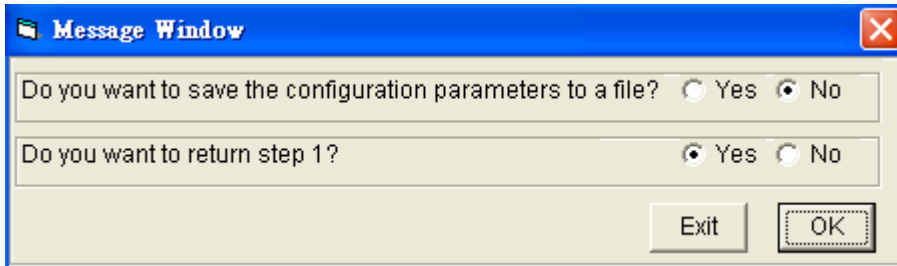

5.4 Configuring the Operating Mode

1. Serial Port Operating Mode – Transparent Mode:

1. Operating Mode:

ZB-2570/2570P: RS-232/RS-485 Interface – **Transparent Mode**.

ZB-2571/2571P: RS-232/RS-485 Interface – **Transparent Mode**.

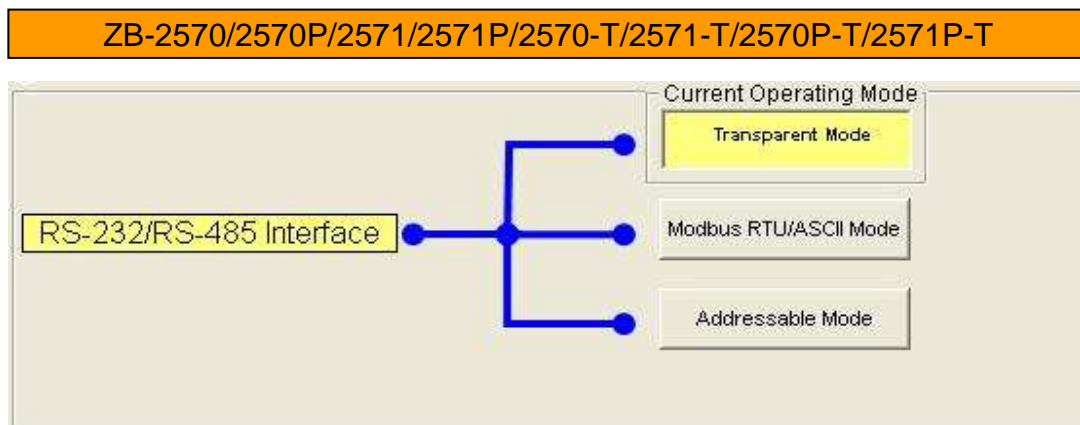

2. ZigBee Parameters: Both the **Pan ID** and the **Channel** must be the same as each other.
3. Interface Parameters: Serial port (RS-232 or RS-485) parameters.

ZB-2570/2570P/2570-T/2570P-T

Set the Parameters

Pan ID: (Please type the hex value)

Node ID: (Please type the hex value)

Channel: (Range: 0 ~ F)

ZB-2570/2570P Serial Port Parameters

Baud Rate:

Data Bit:

Parity Check:

Stop Bit:

ZB-2571/2571P/2571-T/2571P-T

Set the Parameters

Pan ID: (Please type the hex value)

Node ID: (Please type the hex value)

Channel: (Range: 0 ~ F)

Network Presence Detection Time Interval: sec

ZB-2571/2571P Serial Port Parameters

Baud Rate:

Data Bit:

Parity Check:

Stop Bit:

2. Serial Port Operating Mode – Modbus RTU/ASCII Mode:

1. Operating Mode:

ZB-2570/2570P: RS-232/RS-485 Interface – **Modbus RTU/ASCII Mode.**

ZB-2571/2571P: RS-232/RS-485 Interface – **Modbus RTU/ASCII Mode.**

ZB-2570/2570P/2571/2571P/2570-T/2571-T/2570P-T/2571P-T

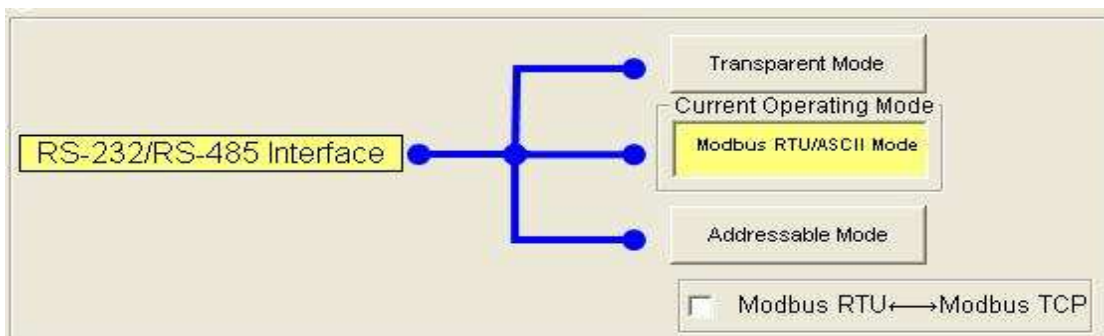

2. ZigBee Parameters: Both the **Pan ID** and the **Channel** must be the same as each other.

3. Interface Parameters: Serial port (RS-232 or RS-485) parameters.

4. Operating Mode Parameters: COM Port receive timeout value.

ZB-2570/2570P/2570-T/2570P-T

Set the Parameters

Pan ID: 00 01 (Please type the hex value)

Node ID: 00 00 (Please type the hex value)

Channel: 9 (Range: 0 ~ F)

Operating Mode Parameters
Silent interval for the Modbus Protocol (default = 3.5 char time): 4

ZB-2570/2570P Serial Port Parameters

Baud Rate: 115200

Data Bit: 8

Parity Check: None

Stop Bit: 1

ZB-2571/2571P/2571-T/2571P-T

Set the Parameters

Pan ID: 00 01 (Please type the hex value)

Node ID: 00 10 (Please type the hex value)

Channel: 9 (Range: 0 ~ F)

Network Presence Detection Time Interval: 20 sec

Operating Mode Parameters
Silent interval for the Modbus Protocol (default = 3.5 char time): 4

ZB-2571/2571P Serial Port Parameters

Baud Rate: 115200

Data Bit: 8

Parity Check: None

Stop Bit: 1

3. Serial Port Operating Mode – Addressable Mode:

1. Operating Mode:

ZB-2570/2570P: RS-232/RS-485 Interface – **Addressable Mode**.

ZB-2571/2571P: RS-232/RS-485 Interface – **Addressable Mode**.

ZB-2570/2570P/2571/2571P/2570-T/2571-T/2570P-T/2571P-T

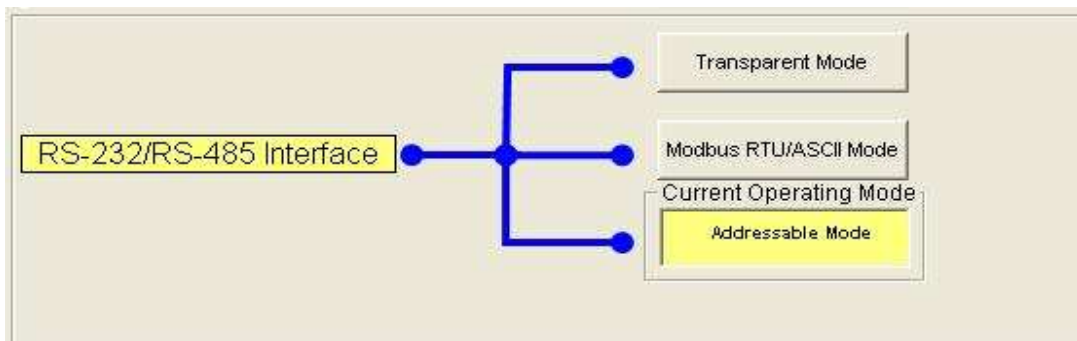

2. ZigBee Parameters: Both the **Pan ID** and the **Channel** must be the same as each other.

3. Interface Parameters: Serial port (RS-232 or RS-485) parameters.

4. Operating Mode Parameters: Must be equal to the **Node ID**.

ZB-2570/2570P/2570-T/2570P-T

Set the Parameters

Pan ID: 00 01 (Please type the hex value)

Node ID: 00 00 (Please type the hex value)

Channel: 9 (Range: 0 ~ F) Set

ZB-2570/2570P Serial Port Parameters

Baud Rate: 115200

Data Bit: 8

Parity Check: None

Stop Bit: 1 Set

ZB-2571/2571P/2571-T/2571P-T

Set the Parameters

Pan ID: 00 01 (Please type the hex value)

Node ID: 00 10 (Please type the hex value)

Channel: 9 (Range: 0 ~ F) Set

Network Presence Detection Time Interval: 20 sec Help Set

Operating Mode Parameters

The connected device ID is used to address a non-addressable device and must be equal to the Node ID. Help

ZB-2571/2571P Serial Port Parameters

Baud Rate: 115200

Data Bit: 8

Parity Check: None

Stop Bit: 1 Set

Ethernet Operating Mode – Transparent Mode:

1. Operating Mode:

ZB-2570/2570P: Ethernet Interface – **Transparent Mode TCP Server/Client.**

ZB-2571/2571P: Ethernet Interface – **Transparent Mode TCP Server/Client.**

ZB-257x/257xP/257x-T/257xP-T as a server

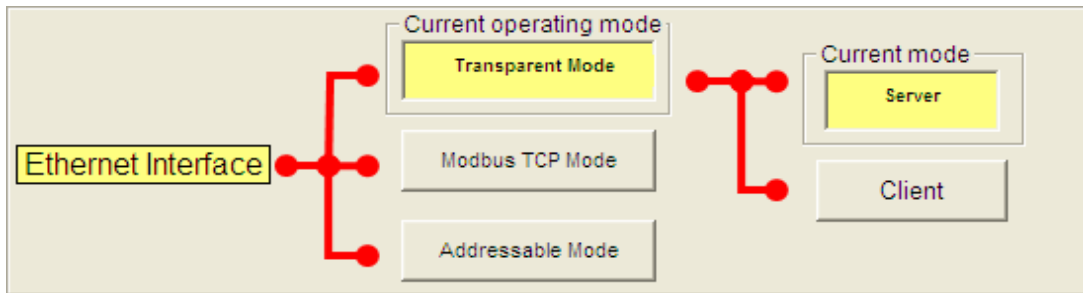

ZB-257x/257xP/257x-T/257xP-T as a client

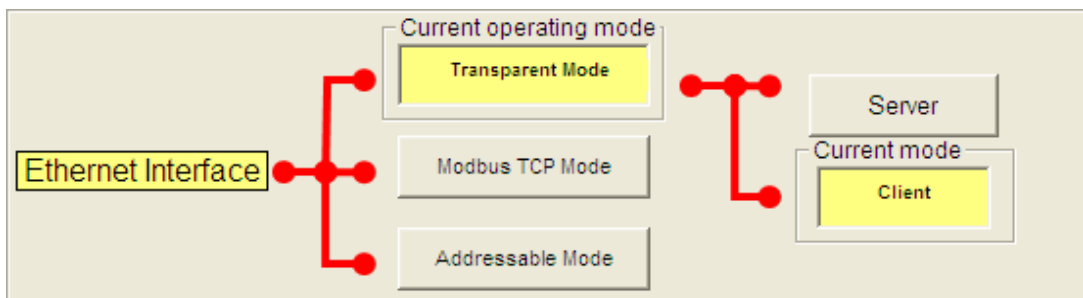

2. ZigBee Parameters: Both the **Pan ID** and the **Channel** must be the same as each other.
3. Interface Parameters: IP Address, Mask, Gateway, Port.
4. Operation Mode Parameters (client): Ethernet parameters for the TCP Server Module.

ZB-2570/2570P/2570-T/2570P-T as a server

Set the Parameters

Pan ID: (Please enter the hex value)

Node ID: (Please enter the hex value)

Channel: (Range: 0 ~ F)

ZB-2570/2570P Ethernet Parameters

IP:

Mask:

Gateway:

Port:

ZB-2570/2570P/2570-T/2570P-T as a client

Set the Parameters

Pan ID: (Please enter the hex value)

Node ID: (Please enter the hex value)

Channel: (Range: 0 ~ F)

ZB-2570/2570P Ethernet Parameters

IP:

Mask:

Gateway:

Port:

TCP Server Module Ethernet Parameters

IP:

Mask:

Gateway:

Port:

ZB-2571/2571P/2571-T/2571P-T as a server

Set the Parameters

Pan ID: (please enter the hex value)

Node ID: (please enter the hex value)

Channel: (range: 0~F)

Network Presence Detection Time Interval: sec

ZB-2571/2571P Ethernet Parameters

IP:

Mask:

Gateway:

Port:

ZB-2571/2571P/2571-T/2571P-T as a client

Set the Parameters

Pan ID: (Please enter the hex value)

Node ID: (Please enter the hex value)

Channel: (Range: 0 ~ F)

Network Presence Detection Time Interval: sec

ZB-2571/2571P Ethernet Parameters

IP:

Mask:

Gateway:

Port:

TCP Server Module Ethernet Parameters

IP:

Mask:

Gateway:

Port:

4. Ethernet Operating Mode – Modbus TCP Mode:

1. Operating Mode:

ZB-2570/2570P: Ethernet Interface – **Modbus TCP Mode & Server/Client.**

ZB-2571/2571P: Ethernet Interface – **Modbus TCP Mode & Server/Client.**

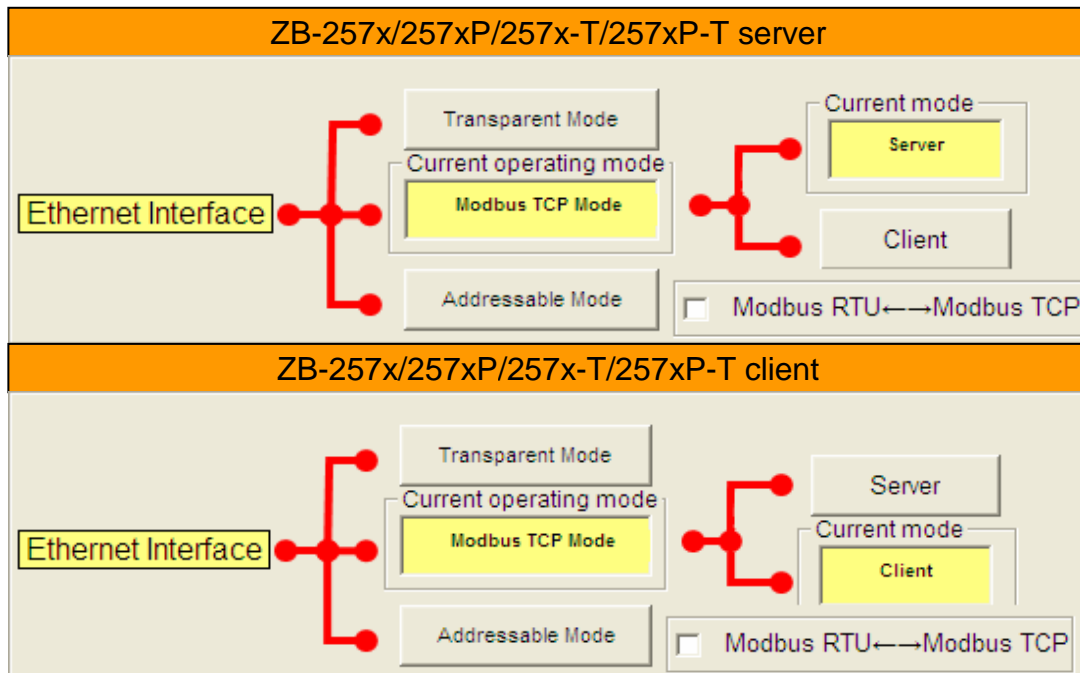

2. ZigBee Parameters: Both the **Pan ID** and the **Channel** must be the same as each other.
3. Interface Parameters: IP Address, Mask, Gateway, Port.
4. Operating Mode Parameters: The mapping address and the Modbus TCP device Ethernet parameters.
5. Operating mode parameters (client): Ethernet parameters for the TCP Server Module.

ZB-2570/2570P/2570-T/2570P-T as a server	
Set the Parameters	
Pan ID: <input type="text" value="00"/> <input type="text" value="01"/> (Please enter the hex value) Node ID: <input type="text" value="00"/> <input type="text" value="00"/> (Please enter the hex value) Channel: <input type="text" value="1"/> (Range: 0 ~ F) <input type="button" value="Set"/>	ZB-2570/2570P Ethernet Parameters IP: <input type="text" value="192.168.255.1"/> Mask: <input type="text" value="255.255.0.0"/> Gateway: <input type="text" value="10.1.0.254"/> Port: <input type="text" value="10000"/> <input type="button" value="Set"/>
ZB-2570/2570P/2570-T/2570P-T as a client	
Set the Parameters	
Pan ID: <input type="text" value="00"/> <input type="text" value="01"/> (Please enter the hex value) Node ID: <input type="text" value="00"/> <input type="text" value="00"/> (Please enter the hex value) Channel: <input type="text" value="1"/> (Range: 0 ~ F) <input type="button" value="Set"/>	ZB-2570/2570P Ethernet Parameters IP: <input type="text" value="192.168.255.1"/> Mask: <input type="text" value="255.255.0.0"/> Gateway: <input type="text" value="10.1.0.254"/> Port: <input type="text" value="10000"/> <input type="button" value="Set"/>
	TCP Server Module Ethernet Parameters IP: <input type="text" value="192.168.255.2"/> Mask: <input type="text" value="255.255.0.0"/> Gateway: <input type="text" value="10.1.0.254"/> Port: <input type="text" value="502"/> <input type="button" value="Set"/>
ZB-2571/2571P/2571-T/2571P-T as a server	
Set the Parameters	
Pan ID: <input type="text" value="00"/> <input type="text" value="01"/> (Please enter the hex value) Node ID: <input type="text" value="00"/> <input type="text" value="01"/> (Please enter the hex value) Channel: <input type="text" value="1"/> (Range: 0 ~ F) <input type="button" value="Set"/>	ZB-2571/2571P Ethernet Parameters IP: <input type="text" value="192.168.255.1"/> Mask: <input type="text" value="255.255.0.0"/> Gateway: <input type="text" value="192.168.0.1"/> Port: <input type="text" value="10000"/> <input type="button" value="Set"/>
Network Presence Detection Time Interval: <input type="text" value="20"/> sec <input type="button" value="Help"/> <input type="button" value="Set"/>	
Operating Mode Parameters NodeID: XX <input type="text" value="01"/> Enter the address of the device to be mapped <input type="text" value="01"/> <input type="button" value="Help"/> <input type="button" value="Set"/>	
ZB-2571/2571P/2571-T/2571P-T as a client	
Set the Parameters	
Pan ID: <input type="text" value="00"/> <input type="text" value="01"/> (Please enter the hex value) Node ID: <input type="text" value="00"/> <input type="text" value="01"/> (Please enter the hex value) Channel: <input type="text" value="1"/> (Range: 0 ~ F) <input type="button" value="Set"/>	ZB-2571/2571P Ethernet Parameters IP: <input type="text" value="192.168.255.1"/> Mask: <input type="text" value="255.255.0.0"/> Gateway: <input type="text" value="192.168.0.1"/> Port: <input type="text" value="10000"/> <input type="button" value="Set"/>
Network Presence Detection Time Interval: <input type="text" value="20"/> sec <input type="button" value="Help"/> <input type="button" value="Set"/>	TCP Server Module Ethernet Parameters IP: <input type="text" value="192.168.255.2"/> Mask: <input type="text" value="255.255.0.0"/> Gateway: <input type="text" value="192.168.0.1"/> Port: <input type="text" value="502"/> <input type="button" value="Set"/>
Operating Mode Parameters NodeID: XX <input type="text" value="01"/> Enter the address of the device to be mapped <input type="text" value="01"/> <input type="button" value="Help"/> <input type="button" value="Set"/>	

5. Ethernet Operating Mode – Addressable Mode:

1. Operating Mode:

ZB-2570/2570P: Ethernet Interface – **Addressable Mode & Server/Client.**

ZB-2571/2571P: Ethernet Interface – **Addressable Mode & Server/Client.**

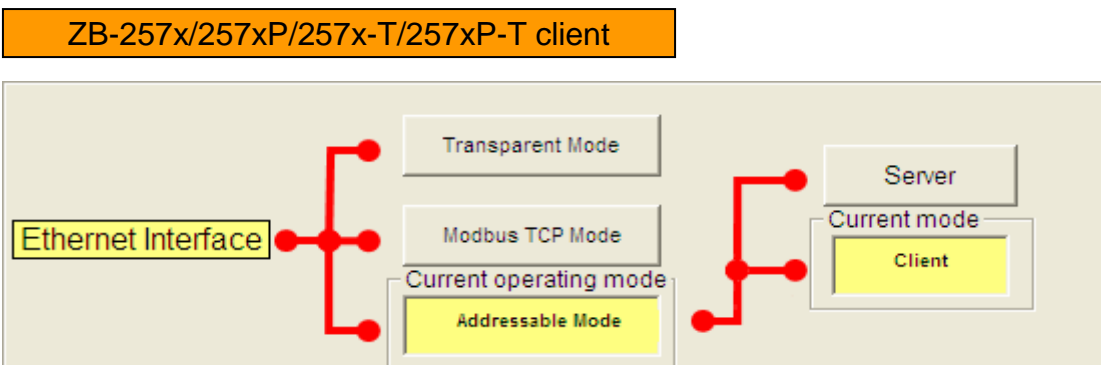
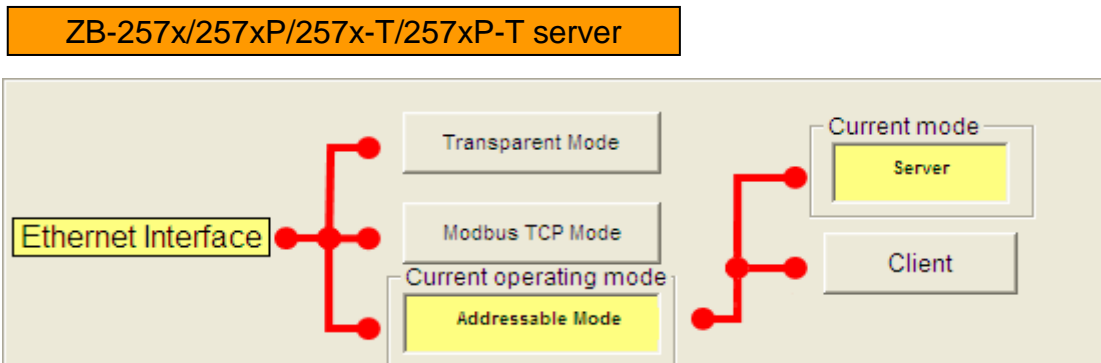

2. ZigBee Parameters: Both the **Pan ID** and the **Channel** must be the same as each other.
3. Interface Parameters: IP Address, Mask, Gateway, Port.
4. Operating mode parameters: Must be equal to the **Node ID**.
5. Operating mode parameters (client): Ethernet parameters for the TCP Server Module.

ZB-2570/2570P/2570-T/2570P-T as a server	
Set the Parameters	
Pan ID: <input type="text" value="00"/> <input type="text" value="01"/> (Please enter the hex value) Node ID: <input type="text" value="00"/> <input type="text" value="00"/> (Please enter the hex value) Channel: <input type="text" value="1"/> (Range: 0 ~ F) <input type="button" value="Set"/>	ZB-2570/2570P Ethernet Parameters IP: <input type="text" value="192.168.255.1"/> Mask: <input type="text" value="255.255.0.0"/> Gateway: <input type="text" value="10.1.0.254"/> Port: <input type="text" value="10000"/> <input type="button" value="Set"/>
ZB-2570/2570P/2570-T/2570P-T as a client	
Set the Parameters	
Pan ID: <input type="text" value="00"/> <input type="text" value="01"/> (Please enter the hex value) Node ID: <input type="text" value="00"/> <input type="text" value="00"/> (Please enter the hex value) Channel: <input type="text" value="1"/> (Range: 0 ~ F) <input type="button" value="Set"/>	ZB-2570/2570P Ethernet Parameters IP: <input type="text" value="192.168.255.1"/> Mask: <input type="text" value="255.255.0.0"/> Gateway: <input type="text" value="10.1.0.254"/> Port: <input type="text" value="10000"/> <input type="button" value="Set"/>
	TCP Server Module Ethernet Parameters IP: <input type="text" value="192.168.255.2"/> Mask: <input type="text" value="255.255.0.0"/> Gateway: <input type="text" value="10.1.0.254"/> Port: <input type="text" value="502"/> <input type="button" value="Set"/>
ZB-2571/2571P/2571-T/2571P-T as a server	
Set the Parameters	
Pan ID: <input type="text" value="00"/> <input type="text" value="01"/> (Please enter the hex value) Node ID: <input type="text" value="00"/> <input type="text" value="01"/> (Please enter the hex value) Channel: <input type="text" value="1"/> (Range: 0 ~ F) <input type="button" value="Set"/>	ZB-2571/2571P Ethernet Parameters IP: <input type="text" value="192.168.255.1"/> Mask: <input type="text" value="255.255.0.0"/> Gateway: <input type="text" value="192.168.0.1"/> Port: <input type="text" value="10000"/> <input type="button" value="Set"/>
Network Presence Detection Time Interval: <input type="text" value="20"/> sec <input type="button" value="Help"/> <input type="button" value="Set"/>	
Operating Mode Parameters The connected device ID is used to address a non-addressable device and is equal to the Node ID. <input type="button" value="Help"/>	
ZB-2571/2571P/2571-T/2571P-T as a client	
Set the Parameters	
Pan ID: <input type="text" value="00"/> <input type="text" value="01"/> (Please enter the hex value) Node ID: <input type="text" value="00"/> <input type="text" value="01"/> (Please enter the hex value) Channel: <input type="text" value="1"/> (Range: 0 ~ F) <input type="button" value="Set"/>	ZB-2571/2571P Ethernet Parameters IP: <input type="text" value="192.168.255.1"/> Mask: <input type="text" value="255.255.0.0"/> Gateway: <input type="text" value="192.168.0.1"/> Port: <input type="text" value="10000"/> <input type="button" value="Set"/>
Network Presence Detection Time Interval: <input type="text" value="20"/> sec <input type="button" value="Help"/> <input type="button" value="Set"/>	TCP Server Module Ethernet Parameters IP: <input type="text" value="192.168.255.2"/> Mask: <input type="text" value="255.255.0.0"/> Gateway: <input type="text" value="192.168.0.1"/> Port: <input type="text" value="502"/> <input type="button" value="Set"/>
Operating Mode Parameters The connected device ID is used to address a non-addressable device and is equal to the Node ID. <input type="button" value="Help"/>	

6. Multi-Interface Mode – Modbus RTU to Modbus TCP Mode:

1. Operating Mode:

ZB-2570/2570P: Serial Interface – **Modbus RTU Mode**.

ZB-2571/2571P: Ethernet Interface – **Modbus TCP Mode Server/Client**.

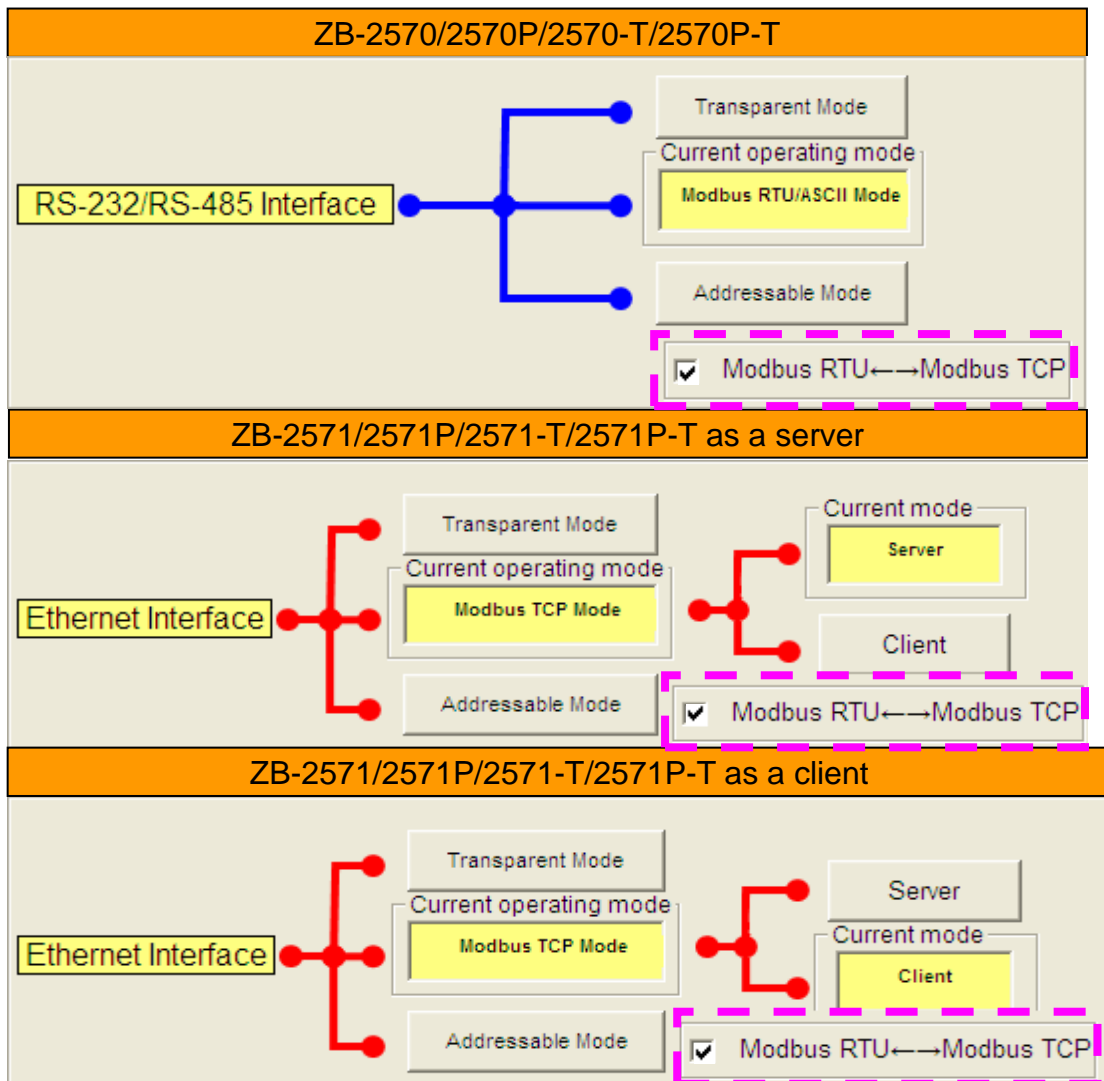

2. ZigBee Parameters:

Both the **Pan ID** and the **Channel** must be the same as each other.

3. Interface Parameters:

ZB-2570/2570P: Serial port (RS-232 or RS-485) parameters.

ZB-2571/2571P: IP Address, Mask, Gateway, Port.

4. Operating Mode Parameters:

ZB-2570/2570P: COM Port receives timeout value.

ZB-2571/2571P: The mapping address and the Modbus TCP device Ethernet parameters.

5. Operating Mode Parameter(client):

ZB-2571/2571P: Ethernet parameters for the TCP Server Module.

ZB-2570/2570P/2570-T.2570P-T

Set the Parameters

Pan ID: <input type="text" value="00"/> <input type="text" value="01"/> (please enter the hex value)	ZB-2570/2570P Serial Port Parameters
Node ID: <input type="text" value="00"/> <input type="text" value="00"/> (please enter the hex value)	
Channel: <input type="text" value="1"/> (range: 0~F) <input type="button" value="Set"/>	
	Baud Rate: <input type="text" value="115200"/>
	Data Bit: <input type="text" value="8"/>
	Parity Check: <input type="text" value="None"/>
	Stop Bit: <input type="text" value="1"/> <input type="button" value="Set"/>

ZB-2571/2571P/2571-T/2571P-T as a server

Set the Parameters

Pan ID: <input type="text" value="00"/> <input type="text" value="01"/> (Please enter the hex value)	ZB-2571/2571P Ethernet Parameters
Node ID: <input type="text" value="00"/> <input type="text" value="01"/> (Please enter the hex value)	
Channel: <input type="text" value="1"/> (Range: 0 ~ F) <input type="button" value="Set"/>	
	IP: <input type="text" value="192.168.255.1"/>
	Mask: <input type="text" value="255.255.0.0"/>
	Gateway: <input type="text" value="192.168.0.1"/>
	Port: <input type="text" value="10000"/> <input type="button" value="Set"/>
Network Presence Detection Time Interval: <input type="text" value="20"/> sec	
<input type="button" value="Help"/> <input type="button" value="Set"/>	
Operating Mode Parameters	
NodeID: XX <input type="text" value="01"/>	
Enter the address of the device to be mapped <input type="text" value="01"/>	
<input type="button" value="Help"/> <input type="button" value="Set"/>	

ZB-2571/2571P/2571-T/2571P-T as a client

Set the Parameters

Pan ID: <input type="text" value="00"/> <input type="text" value="01"/> (Please enter the hex value)	ZB-2571/2571P Ethernet Parameters
Node ID: <input type="text" value="00"/> <input type="text" value="01"/> (Please enter the hex value)	
Channel: <input type="text" value="1"/> (Range: 0 ~ F) <input type="button" value="Set"/>	
	IP: <input type="text" value="192.168.255.1"/>
	Mask: <input type="text" value="255.255.0.0"/>
	Gateway: <input type="text" value="192.168.0.1"/>
	Port: <input type="text" value="10000"/> <input type="button" value="Set"/>
Network Presence Detection Time Interval: <input type="text" value="20"/> sec	
<input type="button" value="Help"/> <input type="button" value="Set"/>	
Operating Mode Parameters	
NodeID: XX <input type="text" value="01"/>	
Enter the address of the device to be mapped <input type="text" value="01"/>	
<input type="button" value="Help"/> <input type="button" value="Set"/>	
	TCP Server Module Ethernet Parameters
	IP: <input type="text" value="192.168.255.2"/>
	Mask: <input type="text" value="255.255.0.0"/>
	Gateway: <input type="text" value="192.168.0.1"/>
	Port: <input type="text" value="502"/> <input type="button" value="Set"/>

7. Multi-Interface Mode – Modbus TCP to Modbus RTU Mode:

1. Operating Mode:

ZB-2570/2570P: Ethernet Interface – **Modbus TCP Mode & Server/Client & Transformer.**

ZB-2571/2571P: Serial Interface – **Modbus RTU Mode & Transformer.**

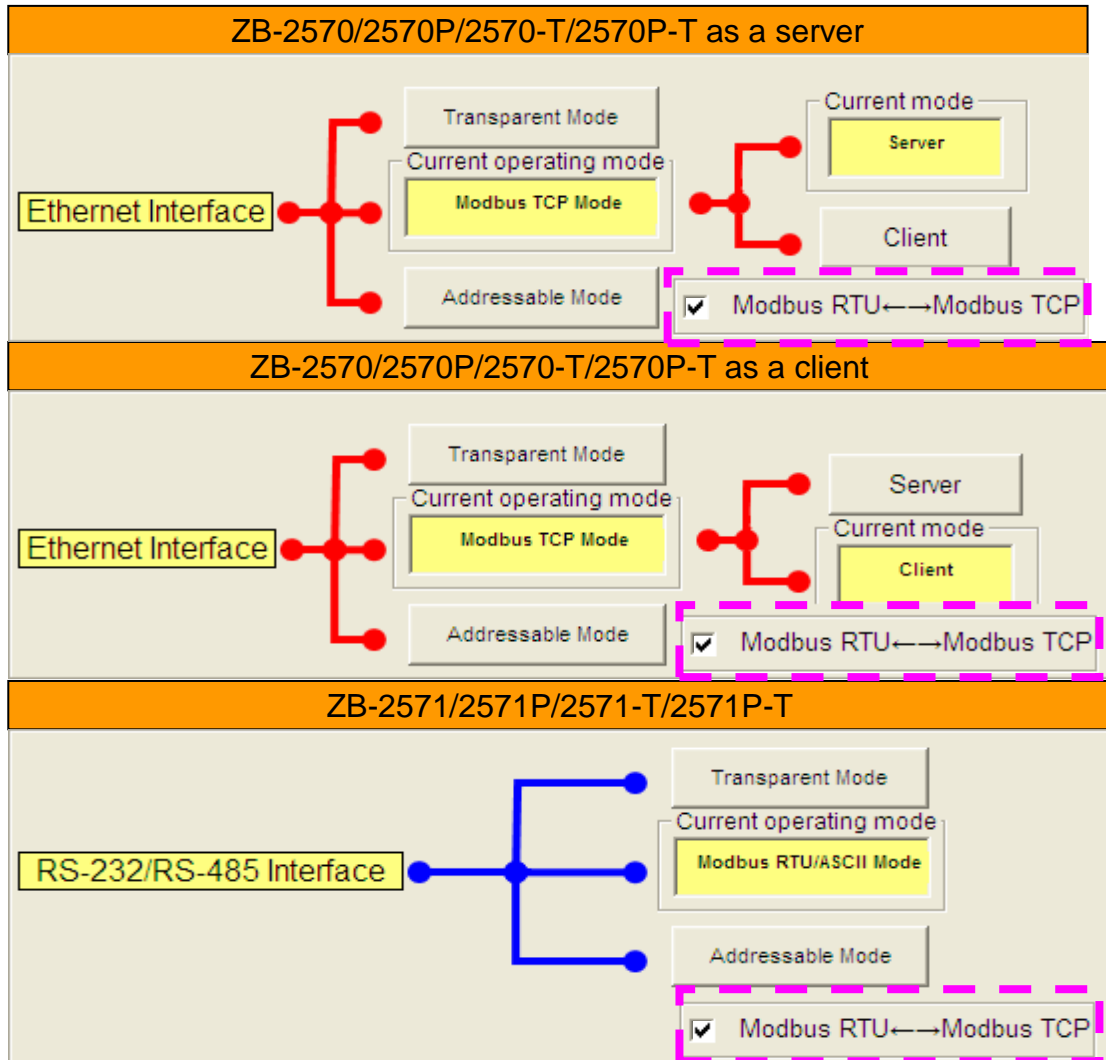

2. ZigBee Parameters:

Both the **Pan ID** and the **Channel** must be the same as each other.

3. Interface Parameters:

ZB-2570/2570P: IP Address, Mask, Gateway, Port.

ZB-2571/2571P: Serial port (RS-232 or RS-485) parameters.

4. Operating Mode Parameters:

ZB-2571/2571P: COM Port receives timeout value.

5. Operating Mode Parameters(client):

ZB-2570/2570P: Ethernet parameters for the TCP Server Module.

ZB-2570/2570P/2570-T/2570P-T as a server

Set the Parameters

Pan ID:	<input type="text" value="00"/> <input type="text" value="01"/>	(Please enter the hex value)
Node ID:	<input type="text" value="00"/> <input type="text" value="00"/>	(Please enter the hex value)
Channel:	<input type="text" value="1"/> <input type="button" value="v"/>	(Range: 0 ~ F)
<input type="button" value="Set"/>		

ZB-2570/2570P Ethernet Parameters	
IP:	<input type="text" value="192.168.255.1"/>
Mask:	<input type="text" value="255.255.0.0"/>
Gateway:	<input type="text" value="10.1.0.254"/>
Port:	<input type="text" value="10000"/>
<input type="button" value="Set"/>	

ZB-2570/2570P/2570-T/2570P-T as a client

Set the Parameters

Pan ID:	<input type="text" value="00"/> <input type="text" value="01"/>	(Please enter the hex value)
Node ID:	<input type="text" value="00"/> <input type="text" value="00"/>	(Please enter the hex value)
Channel:	<input type="text" value="1"/> <input type="button" value="v"/>	(Range: 0 ~ F)
<input type="button" value="Set"/>		

ZB-2570/2570P Ethernet Parameters	
IP:	<input type="text" value="192.168.255.1"/>
Mask:	<input type="text" value="255.255.0.0"/>
Gateway:	<input type="text" value="10.1.0.254"/>
Port:	<input type="text" value="10000"/>
<input type="button" value="Set"/>	

TCP Server Module Ethernet Parameters	
IP:	<input type="text" value="192.168.255.2"/>
Mask:	<input type="text" value="255.255.0.0"/>
Gateway:	<input type="text" value="10.1.0.254"/>
Port:	<input type="text" value="502"/>
<input type="button" value="Set"/>	

ZB-2571/2571P/2571-T/2571P-T

Set the Parameters

Pan ID:	<input type="text" value="00"/> <input type="text" value="01"/>	(please enter the hex value)
Node ID:	<input type="text" value="00"/> <input type="text" value="01"/>	(please enter the hex value)
Channel:	<input type="text" value="1"/> <input type="button" value="v"/>	(range: 0~F)
<input type="button" value="Set"/>		

ZB-2571/2571P Serial Port Parameters	
Baud Rate:	<input type="text" value="115200"/> <input type="button" value="v"/>
Data Bit:	<input type="text" value="8"/> <input type="button" value="v"/>
Parity Check:	<input type="text" value="None"/> <input type="button" value="v"/>
Stop Bit:	<input type="text" value="1"/> <input type="button" value="v"/>
<input type="button" value="Set"/>	

Network Presence Detection Time Interval: sec

Operating Mode Parameters

Silent interval for Modbus Protocol
(default = 3.5 char time).

8. Virtual COM Mode

1. Operating Mode:

ZB-2570/2570P: Virtual RS-232/RS-485 Interface – Transparent Mode.

ZB-2571/2571P: RS-232/RS-485 Interface – Transparent Mode.

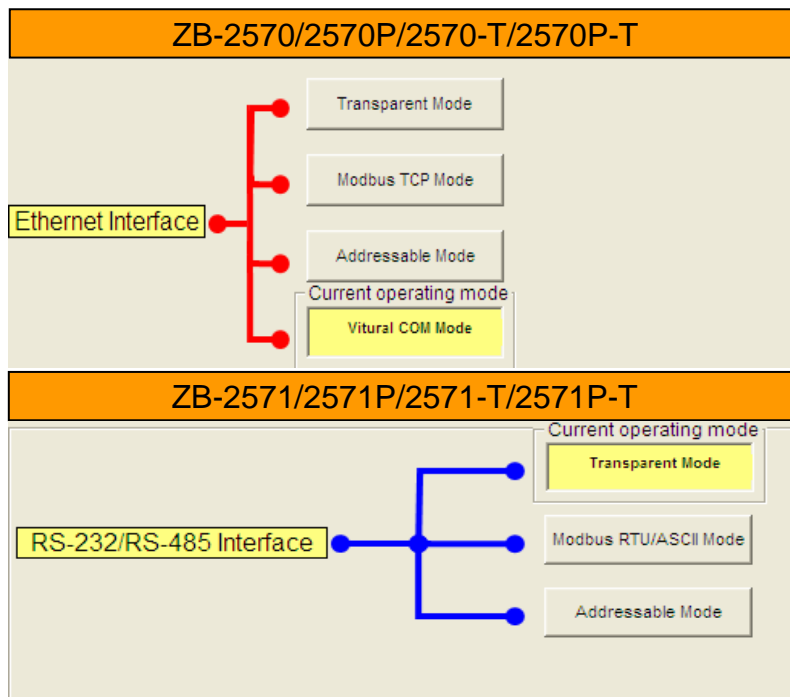

2. ZigBee Parameters: Both the **Pan ID** and the **Channel** must be the same as each other.

3. Interface Parameters: Serial port (RS-232 or RS-485) parameters.

ZB-2570/2570P/2570-T/2570P-T

Set the Parameters

Pan ID:	<input type="text" value="00"/> <input type="text" value="01"/>	(Please type the hex value)
Node ID:	<input type="text" value="00"/> <input type="text" value="00"/>	(Please type the hex value)
Channel:	<input type="text" value="1"/> <input type="button" value="v"/>	(Range: 0 ~ F) <input type="button" value="Set"/>

ZB-2570/2570P Ethernet Parameters

IP:	<input type="text" value="10.1.125.70"/>
Mask:	<input type="text" value="255.255.0.0"/>
Gateway:	<input type="text" value="10.1.0.254"/>
Port:	<input type="text" value="502"/> <input type="button" value="Set"/>

ZB-2571/2571P/2571-T/2571P-T

Set the Parameters

Pan ID:	<input type="text" value="00"/> <input type="text" value="01"/>	(please enter the hex value)
Node ID:	<input type="text" value="00"/> <input type="text" value="01"/>	(please enter the hex value)
Channel:	<input type="text" value="1"/> <input type="button" value="v"/>	(range: 0~F) <input type="button" value="Set"/>

ZB-2571/2571P Serial Port Parameters

Baud Rate:	<input type="text" value="115200"/> <input type="button" value="v"/>
Data Bit:	<input type="text" value="8"/> <input type="button" value="v"/>
Parity Check:	<input type="text" value="None"/> <input type="button" value="v"/>
Stop Bit:	<input type="text" value="1"/> <input type="button" value="v"/> <input type="button" value="Set"/>

Network Presence Detection Time Interval:

5.5 Installing the Hardware

1. Adjust the switch to the **RUN** position then power on the module.

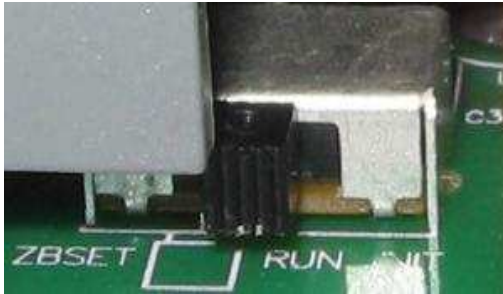

2. Serial Port - RS-232

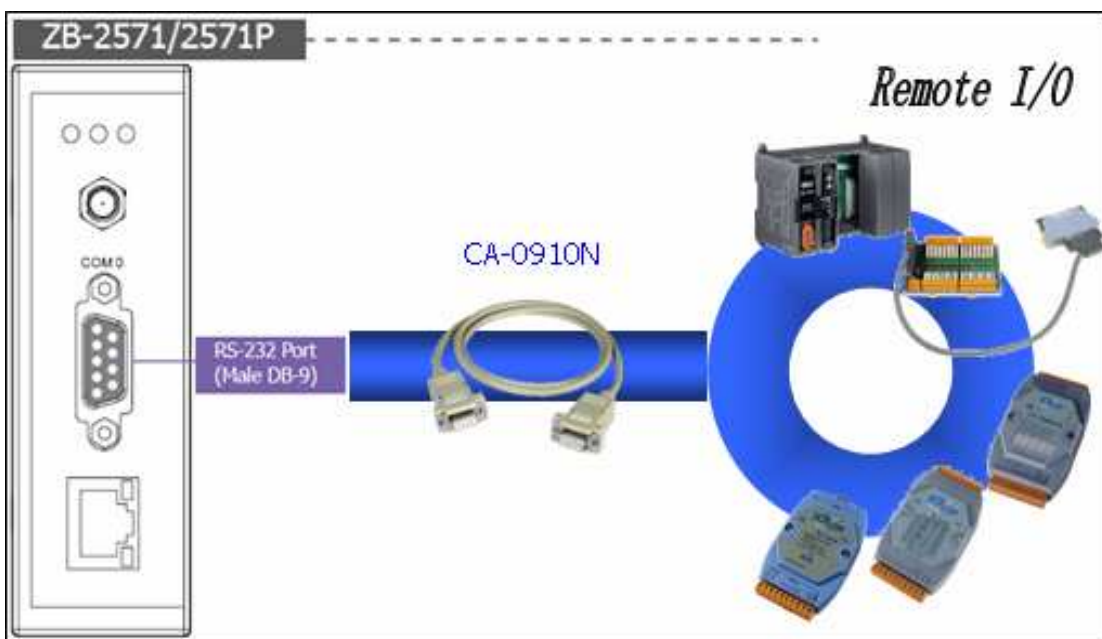

3. Serial Port - RS-485

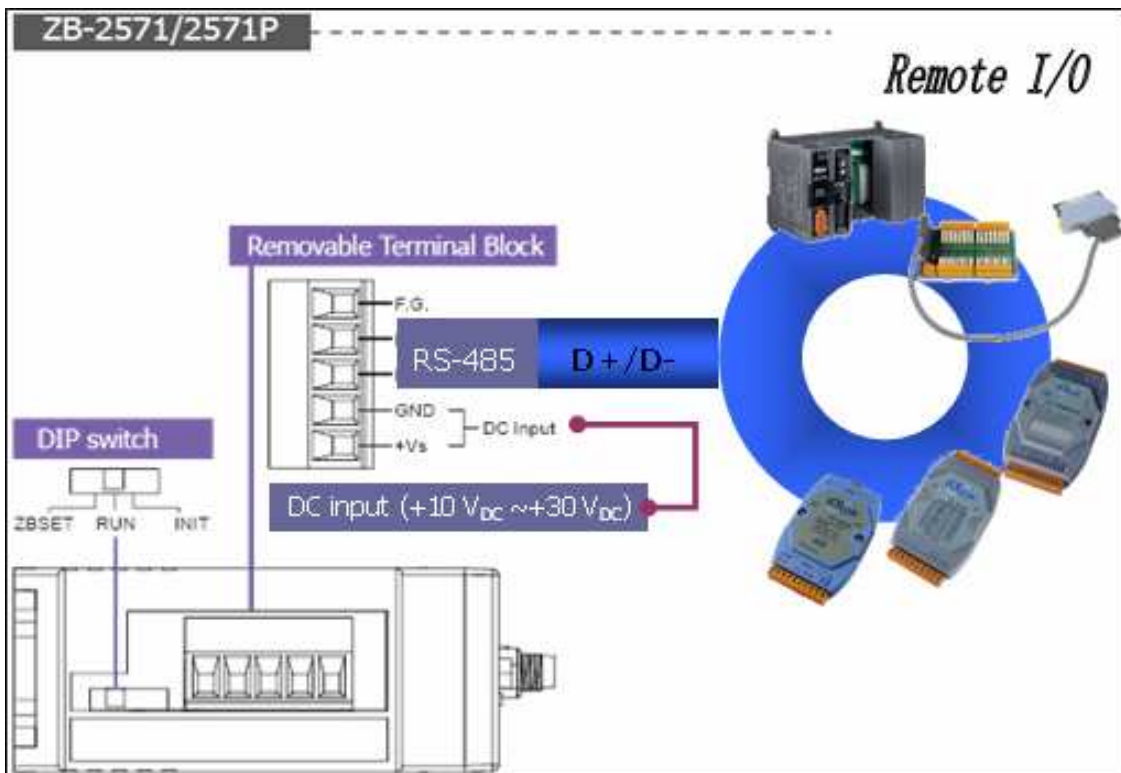
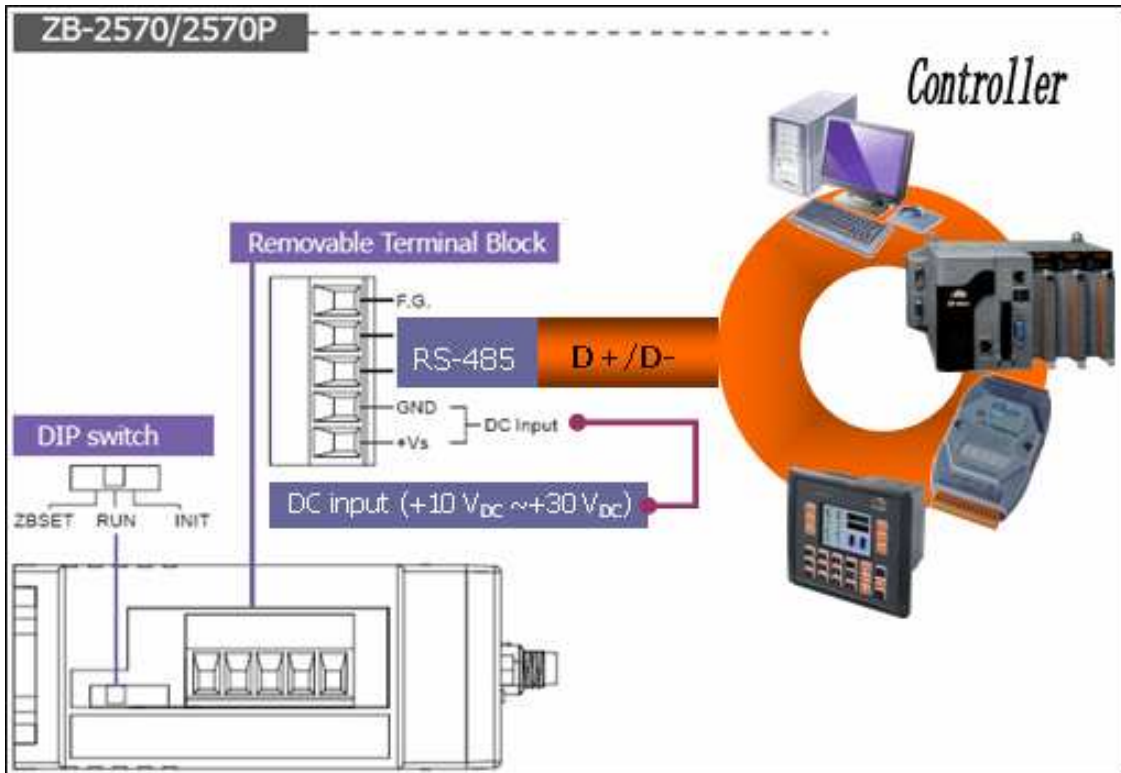

4. Ethernet – RJ-45

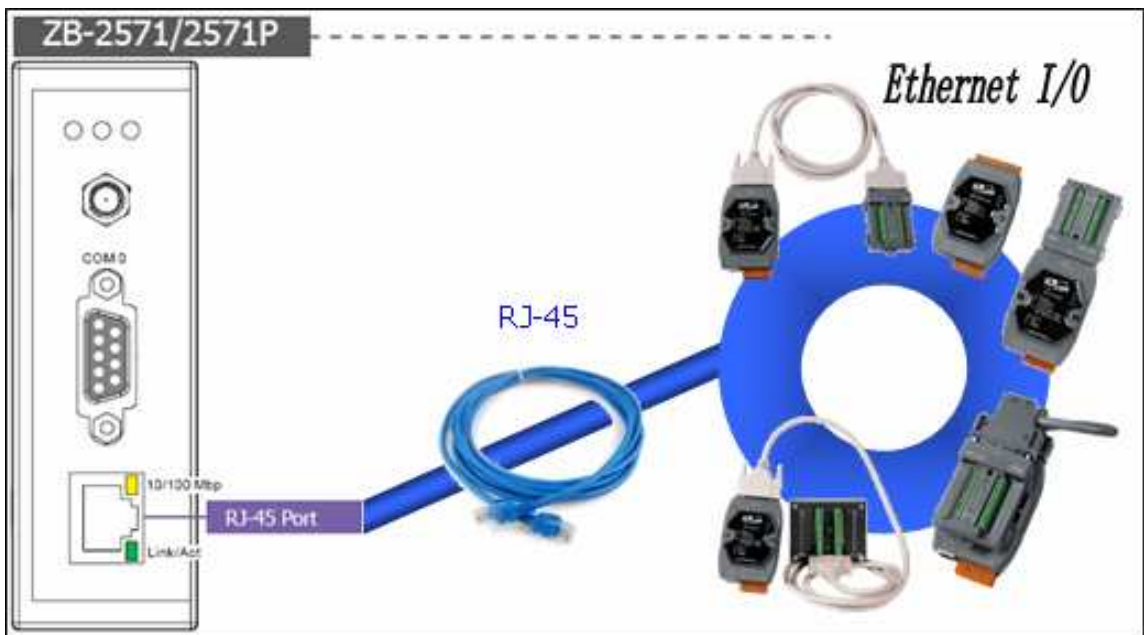
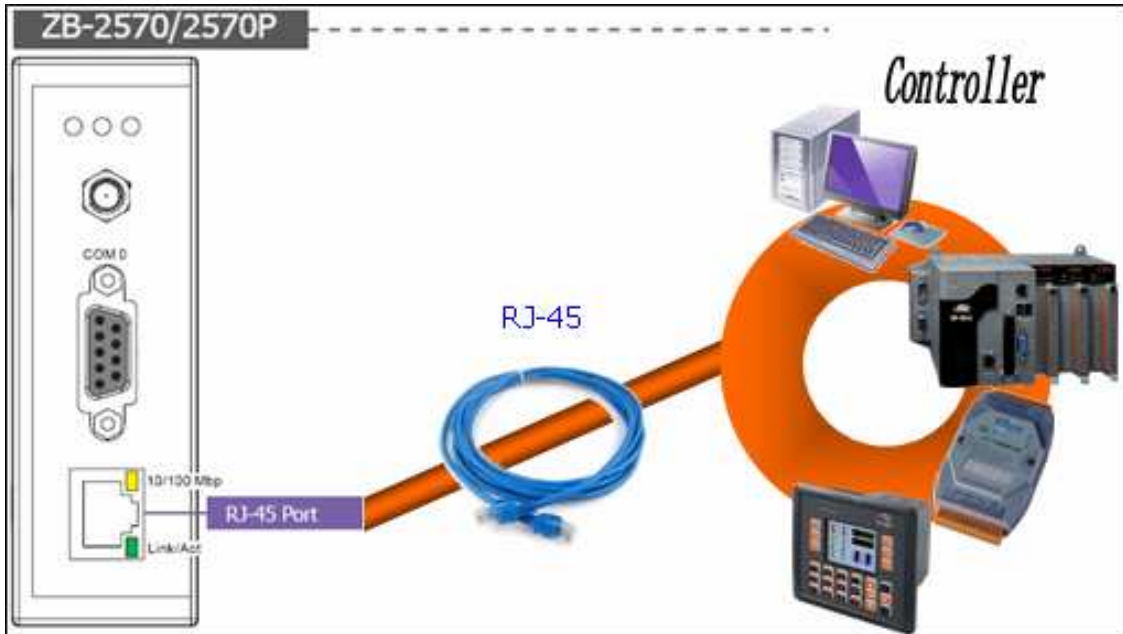

5.6 Confirm the Transmission:

After power on the ZB module, you can check the LED state:

- Zigbee Net (Green LED):
 - Blinking = Zigbee mesh not established.
 - Steady = ZigBee mesh has been successfully created.
- Zigbee RxD (Yellow LED):
 - Blinking = Receive a data from other Zigbee modules.
 - Steady unlight = No data input.
- PWR (Red LED):
 - Steady unlight = Power off.
 - Steady light = power on.

In the ZB-2570/2570P/2570-T/2570P-T:

You will see the red LED and the green are light steady. If it receives any Zigbee signals, the Zigbee RxD LED will be blinking when receiving.

In the ZB-2571/2571P/2571-T/2571P-T:

You will see the red LED light steady and the green LED blinking for seconds. Once the green LED is continually illuminated, it means that the ZigBee mesh has been successfully created. If it receives any Zigbee signals, the Zigbee RxD LED will be blinking when receiving.

6. Appendix

6.1 Beginning Steps:

When you turn on the power of the ZB-2570/2570P/2570-T/2570P-T, you will see a green LED. After you turn on the power of the ZB-2571/2571P/2571-T/2571P-T, you will see the green LED blinking for seconds. Once the green LED is continually illuminated, it means that the ZigBee mesh has been successfully created.

6.2 Resetting parameters to default:

1. In the "Set Parameters" dialog box (see page 23), click the **Default** button.

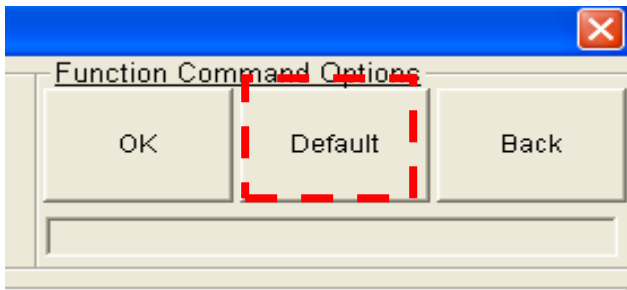

2. Default settings for the ZB-2570/2570P/2570-T/2570P-T:

Pan ID	00 01	
Node ID	00 00	
RF Channel	1	
Encryption	No	
Operating Mode	Transparent Mode	
Serial Port Interface Settings	115200, N, 8, 1	
Ethernet Interface Settings	IP	192.168.255.1
	Mask	255.255.0.0
	Gateway	192.168.0.1
	Port	10000

3. Default settings for the ZB-2571/2571P/2571-T/2571P-T:

Pan ID	00 01	
Node ID	00 01	
RF Channel	1	
Network Presence Detection Time Interval	20 sec	
Operating Mode	Transparent Mode	
Serial Port Interface Settings	115200, N, 8, 1	
Ethernet Interface Settings	IP	192.168.255.1
	Mask	255.255.0.0
	Gateway	192.168.0.1
	Port	10000

6.3 Ping the Device:

Once you have finished configuring the settings, you can use the Ping Device Command to get information related to the RSSI and Location from the ZigBee node. To do this, adjust the switch to the **ZBSET** position, then power on the module. You can use the same utility as you used when configuring the ZB-2570/2570P/2570-T/2570P-T setting. After connecting to the ZB-2570/2570P/2570-T/2570P-T, the **Ping** button will be visible.

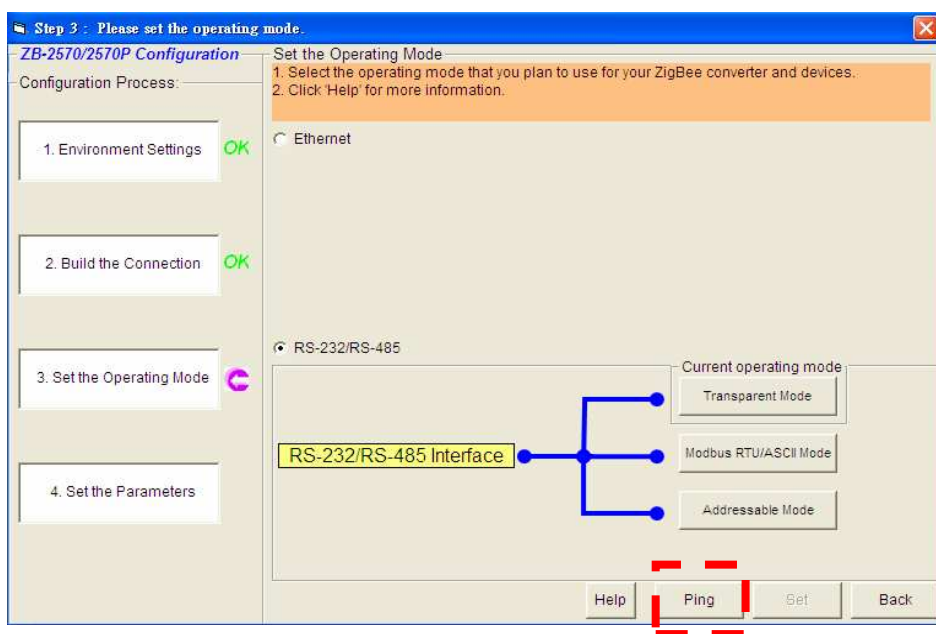

After Clicking this button, the pin dialog box will appears. You can add the NodeIDs that you want to ping and they will be displayed in the ID List. When adding a NodeID, ensure that you don't add an unused NodeID as this will cause incorrect information to be displayed. If you only want to

ping a single node, just click **Ping** button. Alternatively, you can click the **Ping ALL** button to ping all nodes in the ID List. The information from each node will be displayed in the ACK and History field. The ACK field will show the latest information, but the History field will show all information related to the nodes that you have pinged.

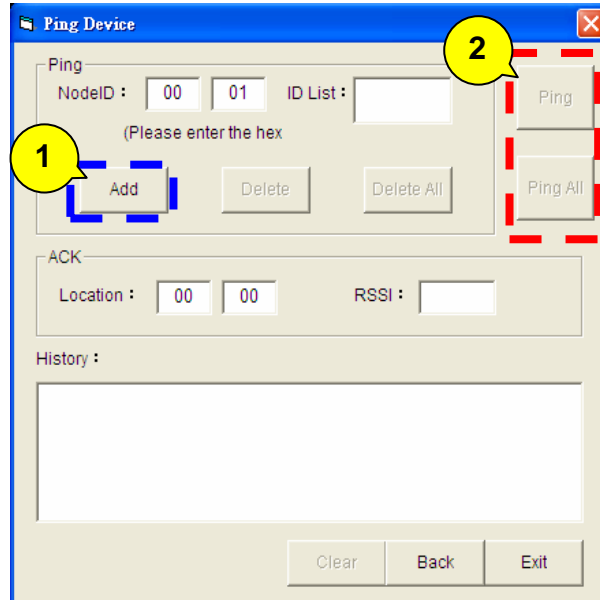

6.4 Connection Procedure:

If the ZB-2570/2570P/2570-T/2570P-T or ZB-2571/2571P/2571-T/2571P-T is set as a TCP client or a Modbus TCP client, first open your software and set the software or device to the listen state, then turn on the power of the ZigBee module and wait for a connection to be establish.

6.5 Included Cables:

Module	Cable	Description
ZB-2570/2570P	CA-0915	9-pin female D-sub and 3-wire RS-232 cable, 1m Cable.
ZB-2571/2571P	CA-0910N	9-pin female-female D-sub cable, 1m Null Modem Cable.

6.6 Network Status Detection Time Setting:

If the value is set to 20, it means that every 20 seconds a packet will be sent to confirm the status of the network. If communication is lost, then a self-recovery of the network will occur. If the value is set to 0, this mechanism will be turned off.



6.7 Virtual COM Mode:

Using VxComm technology, Virtual COM ports can be created on the PC to map the RS-232, RS-485 ports of the ZB-2570/2570P/2570-T/2570P-T. The software running on the PC can operate the Virtual COM ports in the same way as a standard COM port enabling access to the serial devices connected to the ZB-2570/2570P/2570-T/2570P-T. That is to say, the original software developed for the serial devices can access the serial devices via the Ethernet/Internet without any modification.

To use Virtual COM Mode, first install the VxComm Driver. After installation, the VxComm Utility can be used to map the ZB-2570/2570P/2570-T/2570P-T's COM ports.

6.8 Configuration tool download location:

Website:

http://ftp.icpdas.com/pub/cd/usbcd/napdos/zigbee/zigbee_converter/zb_257x/utility/

CD path:

[\Napdos\ZigBee\ZigBee_Converter\ZB-257x\Utility\](#)

6.9 Document download location:

Website:

http://ftp.icpdas.com/pub/cd/usbcd/napdos/zigbee/zigbee_converter/zb_257x/document/

CD path:

[\Napdos\ZigBee\ZigBee_Converter\ZB-257x\ Document \](#)

6.10 ZigBee products website:

http://www.icpdas.com/products/GSM_GPRS/wireless/solutions.htm#6

6.11 Technical Service:

If you have any questions, send a description of your problem to:

service@icpdas.com

7. Ordering Information

ZigBee Converter	
ZB-2570 CR	Ethernet/RS-485/RS-232 to ZigBee Converter (Host) (RoHS)
ZB-2570/S CR	Ethernet/RS-485/RS-232 to ZigBee Converter (Host) (RoHS)+ GPSU06U-6 (Power Supply)
ZB-2571 CR	Ethernet/RS-485/RS-232 to ZigBee Converter (Slave) (RoHS)
ZB-2571/S CR	Ethernet/RS-485/RS-232 to ZigBee Converter (Slave) (RoHS)+ GPSU06U-6 (Power Supply)
ZB-2570P CR	Ethernet/RS-485/RS-232 to High Power Amplifier ZigBee Converter (Host) (RoHS)
ZB-2570P/S CR	Ethernet/RS-485/RS-232 to High Power Amplifier ZigBee Converter (Host) (RoHS)+ GPSU06U-6 (Power Supply)
ZB-2571P CR	Ethernet/RS-485/RS-232 to High Power Amplifier ZigBee Converter (Slave) (RoHS)
ZB-2571P/S CR	Ethernet/RS-485/RS-232 to High Power Amplifier ZigBee Converter (Slave) (RoHS)+ GPSU06U-6 (Power Supply)

8. Accessories

ZigBee Converter	
ZB-2550 CR	RS-485/RS-232 to ZigBee Converter (Host) (RoHS)
ZB-2550/S CR	RS-485/RS-232 to ZigBee Converter (Host) (RoHS)+ GPSU06U-6 (Power Supply)
ZB-2551 CR	RS-485/RS-232 to ZigBee Converter (Slave) (RoHS)
ZB-2551/S CR	RS-485/RS-232 to ZigBee Converter (Slave) (RoHS)+ GPSU06U-6 (Power Supply)
ZB-2550P CR	RS-485/RS-232 to High Power Amplifier ZigBee Converter (Host) (RoHS)
ZB-2550P/S CR	RS-485/RS-232 to High Power Amplifier ZigBee Converter (Host) (RoHS)+ GPSU06U-6 (Power Supply)
ZB-2551P CR	RS-485/RS-232 to High Power Amplifier ZigBee Converter (Slave) (RoHS)
ZB-2551P/S CR	RS-485/RS-232 to High Power Amplifier ZigBee Converter (Slave) (RoHS)+ GPSU06U-6 (Power Supply)
ZigBee Repeater	
ZB-2510 CR	ZigBee Repeater (RoHS)
ZB-2510/S CR	ZigBee Repeater (RoHS) + GPSU06U-6 (Power Supply)
ZB-2510P CR	High Power Amplifier ZigBee Repeater (RoHS)
ZB-2510P/S CR	High Power Amplifier ZigBee Repeater (RoHS) + GPSU06U-6 (Power Supply)
ZigBee DIO	
ZB-2052 CR	Wireless 8-ch Isolated Digital Input Module with 16-bit Counters (RoHS)
ZB-2060 CR	Wireless 6-ch Isolated Digital Input and 4-ch Relay Output Module (RoHS)